

# HASTELLOY® C-22® TUBING & FITTINGS SPECIFICATIONS

## C-22® TUBING SPECIFICATIONS

- Welded tubing in compliance with specification ASTM B626 and ASME SB626
- Seamless tubing in compliance with specification ASTM B622 and ASME SB622
- Specification SB622 and SB626 are recognized by ASME BPE and acceptable for pharmaceutical applications
- Tubing provided in random lengths, 20 ft. + 1.0 in. is typical (not less than 17 ft. lengths)
- Full line stencil identification on tubing OD
- Plastic sleeved and capped protection on polished tubing and electropolishing
- MTR according with EN 10204 3.1 with every order

For more specifications, visit [csidesigns.com/products/superalloys](https://csidesigns.com/products/superalloys)

## C-22 TUBING DIMENSIONS AND TOLERANCE

TUBING OD NOMINAL SIZE		OUTSIDE DIAMETER TOLERANCE		WALL THICKNESS NOMINAL SIZE		WALL THICKNESS TOLERANCE
IN	MM	IN	MM	IN	MM	
1/4	6.35	+/-0.005	+/-0.13	0.035	0.89	+/-10%
3/8	9.53	+/-0.005	+/-0.13	0.035	0.89	+/-10%
1/2	12.7	+/-0.005	+/-0.13	0.065	1.65	+/-10%
3/4	19.05	+/-0.005	+/-0.13	0.065	1.65	+/-10%
1	25.4	+/-0.005	+/-0.13	0.065	1.65	+/-10%
1-1/2	38.1	+/-0.008	+/-0.20	0.065	1.65	+/-10%
2	50.8	+/-0.008	+/-0.20	0.065	1.65	+/-10%
3	76.2	+/-0.010	+/-0.25	0.065	1.65	+/-10%
4	101.6	+/-0.015	+/-0.38	0.083	2.11	+/-10%

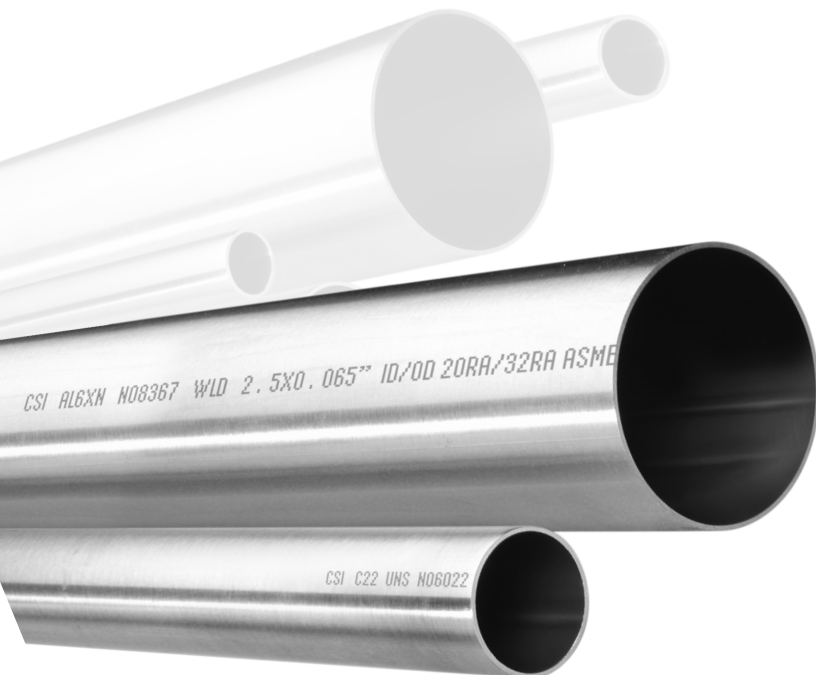

# HASTELLOY® C-22® TUBING & FITTINGS SPECIFICATIONS

## C-22 FITTINGS SPECIFICATIONS

- Fittings comply with ASME BPE table DT-3-1

## C-22 FITTINGS DIMENSIONS AND TOLERANCE

NOMINAL SIZE (IN)	OD (IN)	WALL THICKNESS (IN)	SQUARENESS FACE TO TANGENT, B	OFF ANGLE, O	EQUIVALENT ANGLE DEGREE	OFF PLANE, P	CENTERLINE RADIUS (CLR), R
1/4	±0.005	+0.003/-0.004	0.005	0.009	2.1	0.030	0.563
3/8	±0.005	+0.003/-0.004	0.005	0.012	1.8	0.030	1.125
1/2	±0.005	+0.005/-0.008	0.005	0.014	1.6	0.030	1.125
3/4	±0.005	+0.005/-0.008	0.005	0.018	1.4	0.030	1.125
1	±0.005	+0.005/-0.008	0.008	0.025	1.4	0.030	1.500
1-1/2	±0.008	+0.005/-0.008	0.008	0.034	1.3	0.050	2.250
2	±0.008	+0.005/-0.008	0.008	0.043	1.2	0.050	3.000
3	±0.010	+0.005/-0.008	0.016	0.068	1.3	0.050	4.500
4	±0.015	+0.008/-0.010	0.016	0.086	1.2	0.060	6.000

GENERAL NOTES:  
 Tolerance on end-to-end and center-to-end dimension E is ± 0.050 in. (1.27 mm) for all fittings and process components depicted.  
 See ASME BPE table DT-3-2 for electropolished wall thickness tolerances.  
 Tolerance for centerline radius (CLR) is ± 10% of the nominal dimensions (R).

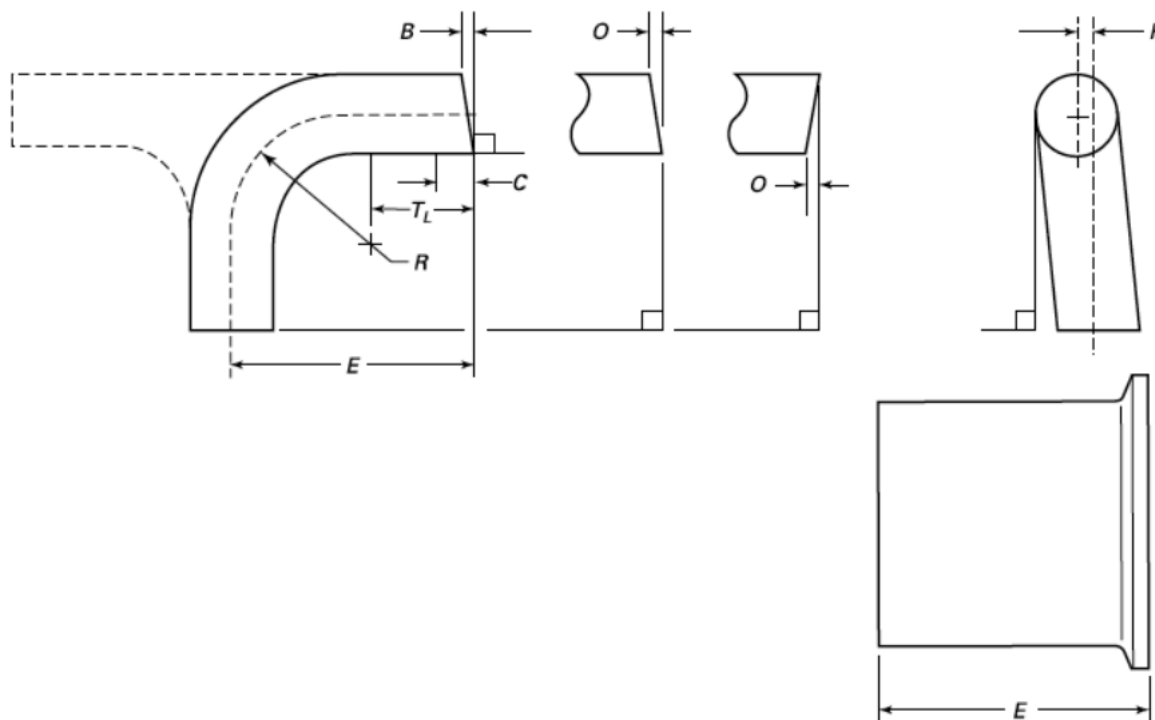

C22 Dims/Tol REV 11/21