



# Instruction Manual

Alfa Laval Rotary Jet Mixer IM 10



Covering:  
Standard Machines

ESE02265-EN8 2022-11

Original manual



# Table of contents

The information herein is correct at the time of issue but may be subject to change without prior notice

<b>1. Declarations of Conformity</b>	<b>4</b>
<b>2. Safety</b>	<b>6</b>
2.1. Important information	6
2.2. Warning signs	6
<b>3. Introduction</b>	<b>7</b>
3.1. Introduction	7
3.2. Marking	8
3.3. Intended use	9
3.4. Patents and trademarks	9
3.5. Quality system	9
<b>4. Installation</b>	<b>10</b>
4.1. General description	10
4.2. Functioning	11
4.3. General safety and installation instructions	13
4.4. Safety Precautions	14
<b>5. Operation</b>	<b>16</b>
5.1. Normal operation	16
<b>6. Maintenance</b>	<b>17</b>
6.1. Service and repair	17
6.2. Preventive maintenance	18
6.3. Assembly of turbine and carrier	20
6.4. Remaining assemblies	22
6.5. Replacement of ball races	24
<b>7. Trouble shooting guide</b>	<b>25</b>
<b>8. Technical data</b>	<b>26</b>
<b>9. Product programme</b>	<b>28</b>
9.1. Standard configuration for Alfa Laval Rotary Jet Mixer IM 10	28
9.2. Available add-ons	29
<b>10. Parts list and drawing, service kit and tools</b>	<b>30</b>
10.1. Alfa Laval Rotary Jet Mixer IM 10	30
10.2. Tools	32
<b>11. General information</b>	<b>33</b>
11.1. Service & repair	33
11.2. How to order spare parts	33
11.3. How to contact Alfa Laval Kolding A/S	33

# 1 Declarations of Conformity

## EU Declaration of Conformity

The Designated Company

Alfa Laval Kolding A/S, Albuen 31, DK-6000 Kolding, Denmark, +45 79 32 22 00

Company name, address and phone number

Hereby declare that

Rotary Jet Mixer

Designation

IM10

Type

Serial number from 2015-0001 to 2030-99999

is in conformity with the following directives with amendments:

- Machinery Directive 2006/42/EC

The person authorised to compile the technical file is the signer of this document.

Global Product Quality Manager

Title

Lars Kruse Andersen

Name

Kolding, Denmark

Place

2022-11-08

Date (YYYY-MM-DD)

Signature

This Declaration of Conformity replaces Declaration of Conformity dated 2016-01-01



# 1 Declarations of Conformity

## UK Declaration of Conformity

The Designated Company

Alfa Laval Kolding A/S, Albuen 31, DK-6000 Kolding, Denmark, +45 79 32 22 00

Company name, address and phone number

Hereby declare that

Rotary Jet Mixer

Designation

IM10

Type

Serial number from 2015-0001 to 2030-99999

is in conformity with the following directives with amendments:

- The Supply of Machinery (Safety) Regulations 2008

Signed on behalf of: Alfa Laval Kolding A/S

Global Product Quality Manager

Title

Lars Kruse Andersen

Name

Kolding, Denmark

Place

2022-11-08

Date (YYYY-MM-DD)



Signature

DoC Revison\_01\_112022

**UK  
CA**



## 2 Safety

---

*Unsafe practices and other important information are emphasized in this manual.*

*Warnings are emphasized by means of special signs.*

***Always read the manual before using the mixer!***

---

### 2.1 Important information

---

#### **WARNING**

Indicates that special procedures must be followed to avoid serious personal injury.

#### **CAUTION**

Indicates that special procedures must be followed to avoid damage to the mixer.

#### **NOTE**

Indicates important information to simplify or clarify procedures.

---

### 2.2 Warning signs

---

General warning:



### 3.1 Introduction

---

#### Introduction

This manual has been prepared as a guide for the persons who will be operating and maintaining your Alfa Laval Rotary Jet Mixer IM 10. The key to long life for your mixer will always be a system of carefully planned maintenance procedures; you will appreciate that a mixer which has a rough job to do will need more frequent attention than one working in ideal conditions.

**Note:** Get the best and most economical performance from your tank cleaning machine. Insufficient preventive maintenance means poor performance, unscheduled stops, shorter lifetime and extra costs. Good preventive maintenance on the contrary means good performance, no unscheduled stops and superior total economy.

You will find the information contained in this manual simple to follow, but should you require further assistance, our Technical Department will be pleased to help you. Please quote the type and serial number with all your enquiries; this will help us to help you. The type and serial number are placed on the gear house of the mixer.

**Note:** The illustrations and specifications contained in this manual were effective at the date of printing. However, as continuous improvements are our policy, we reserve the right to alter or modify any unit specification on any product without prior notice or any obligation.

**Warning:**



Before installing the machine and setting it into operation carefully read the General Safety and Installation Instructions (page 13) and the Safety Precautions (page 14) and take all necessary precautions according to your application and local regulations.

The English version of the instruction manual is the original manual. We make reservations in regard to possible mistranslations in language versions of the instruction manual. In case of doubt, the English version of the instruction manual applies.

© Alfa Laval Corporate AB

*This document and its contents is owned by Alfa Laval Corporate AB and protected by laws governing intellectual property and thereto related rights. It is the responsibility of the user of this document to comply with all applicable intellectual property laws. Without limiting any rights related to this document, no part of this document may be copied, reproduced or transmitted in any form or by any means (electronic, mechanical, photocopying, recording, or otherwise), or for any purpose, without the expressed permission of Alfa Laval Corporate AB. Alfa Laval Corporate AB will enforce its rights related to this document to the fullest extent of the law, including the seeking of criminal prosecution.*

### 3 Introduction

---

#### 3.2 Marking

---

Alfa Laval tank cleaning machines are all marked to allow recognition of machine type, machine name, Serial number and manufacturing address. The marking are placed on the gear house of the mixer.

**Marking**  
**Rotary Jet Mixer**  
**IsoMix IM10**  
**Patent: EP 1 324 818**  
**s/n.: yyyy-xxxxx**  
Alfa Laval, DK-6000 Kolding, Albuen 31  
CE

**Serial number explanation**  
Machines supplied with or without normal documentation:  
yyyy-xxxxx: serial number  
      yyyy: year  
      xxxxx: 5 digit sequential number

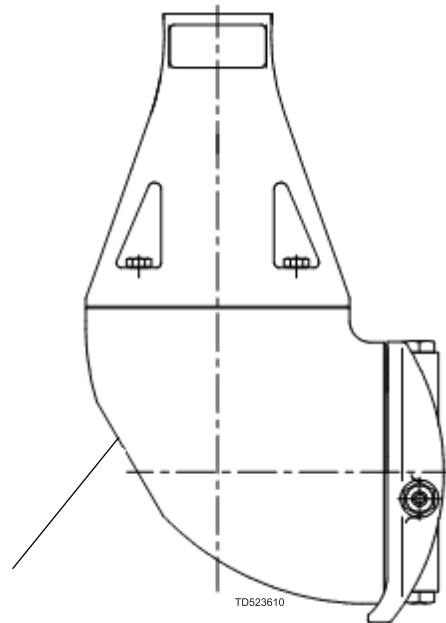

Marking area

---



### 3.3 Intended use

---

It is to be verified by the end-user:

- that the tank cleaning machine is in conformity with respect to tank, vessel or container size in which it will be used.
  - the constructions materials (both metallic and non-metallic) are compatible with product, flushing media, cleaning media, temperatures and pressure under the intended use.
- 

### 3.4 Patents and trademarks

---

This Instruction Manual is published by Alfa Laval Kolding A/S without any warranty. Improvements and changes to this Instruction Manual may at any time be made by Alfa Laval Kolding A/S without prior notice. Such changes will, however, be incorporated in new editions of this Instruction Manual.

Alfa Laval Kolding A/S. All rights reserved.

Alfa Laval Rotary Jet Mixer IM 10 product has patents in the EPO member states and in other countries. The Alfa Laval logotype is a trademark or a registered trademark of Alfa Laval Corporate AB. Other products or company names mentioned herein may be the trademarks of their respective owners. Any rights not expressly granted herein are reserved.

---

### 3.5 Quality system

---

The Alfa Laval Mixers are produced according to Alfa Laval Kolding's ISO 9001 international Standard certified quality system.

---

## 4 Installation

---

### 4.1 General description

---

The Alfa Laval Rotary Jet Mixer IM 10 is a media driven and media lubricated tank/reactor mixer. All materials are selected for contact with food, and the machine is self-cleaning i.e. all internal and external surfaces are cleaned.

#### The Rotary Jet Mixing technology

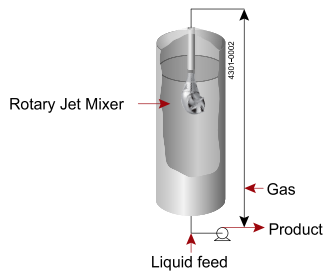

A = Rotary Jet Mixer  
B = Gas  
C = Product  
D = Liquid feed

#### Traditional Mixing technology

##### Round pumping

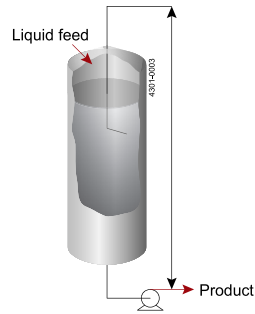

A = Liquid feed  
B = Product

##### Propeller mixing

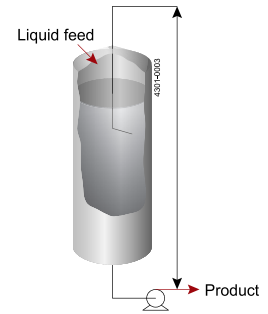

## 4.2 Functioning

The Alfa Laval Rotary Jet Mixer IM 10 is placed inside the tank/reactor under the liquid surface of the liquid volume to be mixed.

The mixer is combined with an external recirculation loop. The fluid of the tank/reactor is recirculated through this loop and reintroduced in the tank/reactor through the Alfa Laval Rotary Jet Mixer IM 10. The more fluid being recirculated, the more effective mixing is obtained.

The mixer should be placed in the centre of the fluid to be mixed. Minimum 200 mm under the liquid surface.

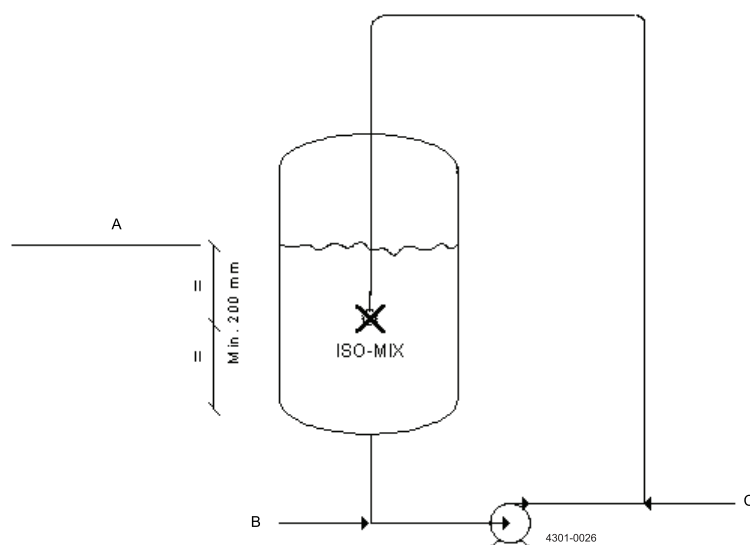

A: normal liquid level

B: Possible liquid or powder supply

C: Possible gas supply

The flow of fluid to be mixed passes from the tank into the mixer through a turbine, which is set into rotation. The turbine rotation is through a gearbox transformed into a combined horizontal rotation of the mixer body and a vertical rotation of the nozzles.

The combined motion of the mixer body and the nozzles ensures a fully indexed tank mixing. After 55/8 revolutions of the hub cover with nozzles (53/8 revolutions of the mixer body), one coarse cleaning pattern is laid out on the tank surface and the first cycle has been made. During the following cycles, this pattern is repeated 7 times, each of which is displaced, and the pattern gradually becomes denser. Finally, after 8 cycles - a total of 45 revolutions of the hub cover with nozzles (43 revolutions of the mixer body), a complete mixing pattern has been laid out, and the first pattern is repeated. This feature eliminates "dead zones" in the tank, and makes the Alfa Laval Rotary Jet Mixer IM 10 a very efficient automatic tank cleaning machine, when the tank is empty.

## 4 Installation

---

This is illustrated below for spherical tank with the machine placed in the centre:

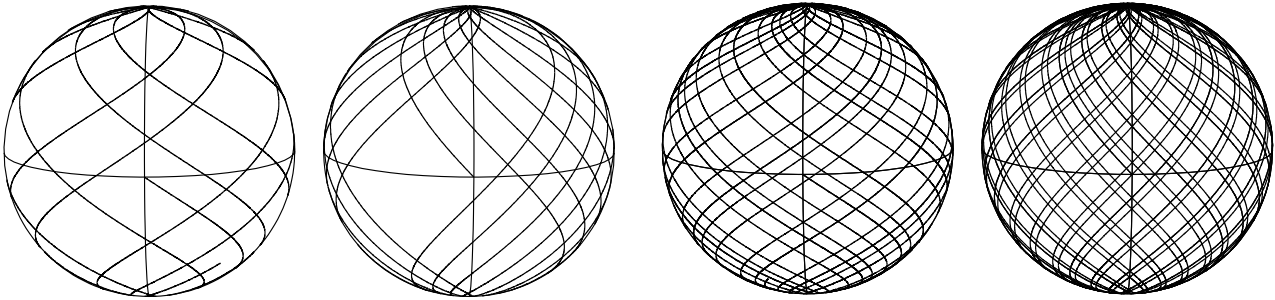

It is possible to add fluid, gas or solids in the recirculation loop. These ingredients will very effectively be mixed into the entire tank/reactor volume.

When the tank/reactor is empty the Alfa Laval Rotary Jet Mixer IM 10 can be used as a tank cleaning machine.

Apart from the main flow flushing the gear and the hub, and thereafter forming the jets through the nozzles, fluid is flushed through all internal areas, through bevel gear, ball bearings and gaps between moving parts and is finally also used for cleaning of the outside surfaces of the machine. The areas behind the screws on the cone are cleaned through small spray holes behind the screws. In the bottom of the body, the machine is equipped with a hole to ensure self-draining. This self-draining is only ensured, if the machine is installed in upright position.

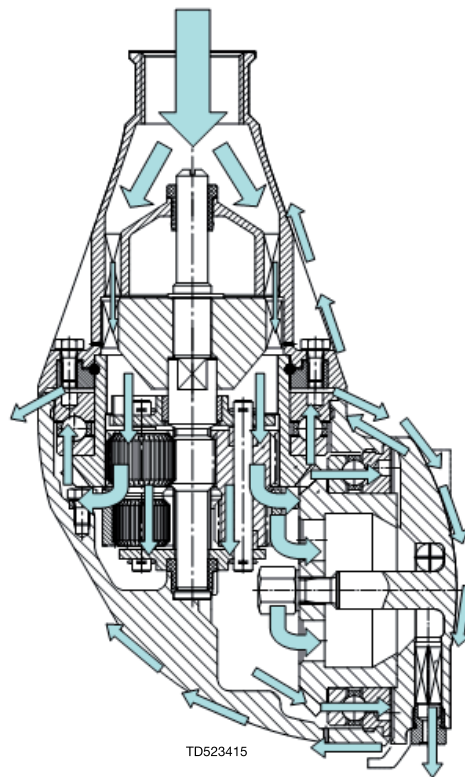

### 4.3 General safety and installation instructions

---

The Alfa Laval Rotary Jet Mixer IM 10 should be installed in vertical position (upright or upside down). It is recommended to install a filter in the supply line in order to avoid large particles to clog inside the machine. Before connecting the mixer into the system, all supply lines and valves should be flushed to remove foreign matter.

It is recommended to secure the bolted connection between machine and down pipe against loosening to vibrations. Use locking wire, nabs or equivalent for the actual application.

In general a filter with 3 mm holes is recommended in the supply line. In case of fine solid particles below 500 µm in the cleaning fluid, choose filter size accordingly.

It is recommended that the fluid valve fitted is of a type that prevents hydraulic shocks, which may cause severe damage to the entire installation.

The machine should be screwed tightly onto its supporting supply line using a 36 mm flat jawed spanner (tool no. 81B040) and the flats machined on the inlet cone.

For devices with tapered thread connections to the down pipe, it is recommended that you secure the connection in a manner appropriate for the application. Subject to the intended use environment and any in-house user requirements or policies, an adhesive such as Loctite No. 243 or equivalent could be used. Other methods could be acceptable and subject to customer preference.

**Warning:**



If the machine is used in potential explosive atmospheres, tapes or joint sealing compounds which are electrical insulators must not be used on threads or joints, unless an electrical connection is otherwise established to ensure an effective earthing. In addition, connecting pipe work, must be electrically conductive and earthed to the tank structure. The resistance between the nozzles and the tank structure should not exceed 20,000 Ohm. This is essential to avoid the build-up of static electricity on the machine. For further information see IEC/TS 60079-32-1:2013 Safety of Machinery, guidance and recommendations for the avoidance of hazards due to static electricity.

**Note:** The Alfa Laval Rotary Jet Mixer IM 10 shall be installed in accordance with national regulations for safety and other relevant regulations and standards. In EU-countries the complete system must fulfill the EU-Machine Directive and depending of application, the EU-Pressure Equipment Directive, the EU-ATEX Directive and other relevant Directives and shall be CE-marked before it is set into operation.

Check that the mixer is in operating condition by inserting 3/16" Hex Screwdriver (tool no. 134A) in screw in top of turbine shaft and easily turn turbine shaft anti-clockwise. If any resistance is recognised, the mixer should be disassembled in order to localise the cause.

## 4 Installation

---

---

### 4.4 Safety Precautions

---

**Warning:**



Precautions shall be made to prevent starting of the cleaning operation, while personnel are inside the tank or otherwise can be hit by jets from the nozzles.

**ATEX Warning:**



In case potentially explosive liquids are used, precautions should be taken against incidental creation of an explosive mixture with oxygen in the tank atmosphere.

**ATEX Warning:**



If the machine is used in potential explosive atmospheres, tapes or joint sealing compounds which are electrical insulators must not be used on threads or joints, unless an electrical connection is otherwise established to ensure an effective earthing. In addition, connecting pipe work, must be electrically conductive and earthed to the tank structure. The resistance between the nozzles and the tank structure should not exceed 20,000 Ohm. This is essential to avoid the build-up of static electricity on the machine. For further information see IEC/TS 60079-32-1:2013 Safety of Machinery, guidance and recommendations for the avoidance of hazards due to static electricity.

Electrical equipment such as magnetic valves and electric actuators must not be installed in Ex-zones without type approval and marking, corresponding to the EX-class in question.

---



## 5 Operation

---

### 5.1 Normal operation

---

#### **Media to be mixed**

Use mixer only in fluids compatible with stainless steel AISI 316L, SAF 2205, PFA, PEEK, PVDF, A4/EPDM and ceramics (Al<sub>2</sub>O<sub>3</sub>). Furthermore, the fluids to be mixed should not contain abrasive materials and fibrous material and the viscosity should not be above 450 cP. Normal detergents, moderate solutions of acids and alkalis will be acceptable. Aggressive chemicals, excessive concentrations of chemicals at elevated temperatures, as well as certain hydrochlorides should be avoided. If you are in doubt, contact Alfa Laval Kolding A/S.

#### **After-use cleaning**

After use flush the mixer with fresh water. Fluids should never be allowed to dry or set-up in the Alfa Laval Rotary Jet Mixer IM 10 due to possible "salting out" or "scaling" of the ingredient.

#### **Pressure**

Avoid hydraulic shocks. Increase pressure gradually. Do not exceed 8 bar inlet pressure. Recommended inlet pressure: 5-7 bar. High pressure in combination with high flow rate will create consumption of wear parts. If the pump in the recirculation loop is a positive pump giving pressure fluctuation, it is recommended to install a hydrofor in the pipeline.

---



### 6.1 Service and repair

---

#### **Recommended Service Intervals**

Inspection every 1000 working hours. After 4000 working hours: inspection every 500 hours.

A service consists of:

0. At a pressure of 0.3 bar open a hatch in the tank to verify rotation and liquid fans are emerging from all slots.  
ATTENTION: Use only pure water at normal temperature for safety reason

If needed proceed to 1).

1. Un-install the machine.
2. Visual inspection for foreign objects. Remove any objects and clean before rotation verification.
3. Rotation verification by hand for free rotation.
4. Reinstall machine.
5. Fill in the Service Log

## 6 Maintenance

---

---

---

### 6.2 Preventive maintenance

---

In order to keep your Alfa Laval Rotary Jet Mixer IM 10 servicing you as an efficient tool in your mixing operations, it is essential to maintain its high performance by following a simple preventive maintenance programme, which will always keep your mixer in good condition.

Good maintenance is careful and regular attention!

The following recommended preventive maintenance is based on a Alfa Laval Rotary Jet Mixer IM 10 working in average conditions. However, you will appreciate that a mixer, which has a rough and dirty job to do, will need more frequent attention than one working in ideal conditions. We trust that you will adjust your maintenance programme to suit.

Alfa Laval Tank Cleaning Equipment Service Kits contain all you need. They comprise genuine Alfa Laval spare parts, manufactured to the original specifications.

Always use only proper tools. Use standard tool kit for Alfa Laval Rotary Jet Mixer IM 10 (page 32). If not stated otherwise never use unnecessary force (i.e. hammer or pry) components together or apart. Always perform all assembly/disassembly steps in the order described in this manual.

Never assemble components without previous cleaning. This is especially important at all mating surfaces. Work in a clear well lighted work area.

According to "Regulation (EC) No 1935/2004 - Article 17" effective from 27th of October 2006, producers of food shall ensure traceability of the materials and articles intended to come into contact with foodstuffs. It is recommended that a traceability system is setup for replacement of wear parts and spare parts. This makes it possible to identify into which machine a given wear part or spare part has been inserted.

**Note:** Get the best and most economical performance from your mixer. Insufficient preventive maintenance means poor performance, unscheduled stops, shorter lifetime and extra costs. Good preventive maintenance on the contrary means good performance, no unscheduled stops and superior total economy.

#### Every 2500 working hours

1. Disassemble machine as described on the following pages.
2. Clean material build-up and deposits from internal parts with chemical cleaner and/or desired fine abrasive cloth.
3. Check slide bearing (pos. 14, page 21) for wear. If end face of slide bearing is worn more than 1 mm into slide bearing, it should be replaced.
4. Check bearings for turbine shaft (pos. 3, page 21 and pos. 24 page 19) in cone and body. If holes are worn oval to a max diameter of more than 10.4 mm, bearings should be replaced. Thickness of collar is to be min. 3.5 mm for bearing in body.
5. Check carrier bearing (pos. 15.3, page 19). If worn oval to a max diameter of more than 15.8 mm, it should be replaced.

**Note:** Timely replacement of ball bearings and collar bushes will prevent costly damage to the gearbox.

6. Check planet wheels (pos. 15.4 and 15.5, page 19) while still mounted in planet gear carrier (pos. 15.6, page 19). They must rotate easily on shafts. If restriction or much clearance on shafts is felt, planet wheels should be dismantled for inspection of bearing bushes and shafts for planet wheel (pos. 15.2, page 19). Max diameter of holes: 6.2 mm. Check tooth wear. If replacement is necessary, planet wheels must be replaced as a pair.
7. Check unrestricted rotation of ball bearings. Inspect for build-up of foreign material in ball retainers (pos. 10, page 21) and ball races (pos. 16.2 and 17.2 page 21).
8. Assemble machines as described in the following pages.
9. Check that the machine is in operating condition by inserting 3/16" Hex screwdriver (tool no. 134A) in screw in top of turbine shaft, and easily turn turbine shaft anti-clockwise. If any resistance is recognised, the machine should be disassembled in order to localise the cause.

Apart from the parts specifically mentioned above, all the remaining wear parts should regularly be inspected for wear. Wear parts are specified in the Reference List of Parts, page 30

---

## 6 Maintenance

---

### 6.3 Assembly of turbine and carrier

---

#### Disassembly

1. Remove M5 screws (pos. 8). Loosen and unscrew with a socket wrench (tool no. 462A).
2. Lift off cone (pos. 1).
3. Withdraw turbine shaft (pos. 2) with impeller. If necessary, turn turbine shaft left and right.
4. Remove circlip (pos. 4) and pull off impeller (pos. 5).
5. Withdraw carrier assembly (pos. 15) while turning/rocking carrier left and right.
6. Remove cotter pins (pos. 15.7), pull out shafts (pos. 15.2) and remove planet wheels (pos. 15.4 and 15.5). If necessary, push out carrier bearing (pos. 15.3)
7. If necessary, push out bearing for turbine shaft (pos. 24) from cone (pos. 1).

#### Reassembly

Before reassembly, make sure that all parts are clean without deposits or build-up of foreign matter.

1. Insert bearing (pos. 24) in top of cone (pos. 1) and push home.
2. Insert carrier bearing (pos. 15.3) and push with thumb. Insert planet wheels (pos. 15.4 and 15.5) and shafts (pos. 15.2) and secure with cotter pins (pos. 15.7). Check free rotation of planet wheels.
3. Insert carrier assembly (pos. 15), into body: Insert through stem (pos. 16, page 21). Hold body in one hand and use the other to turn hub cover (pos. 19) left and right with small rocking movements until carrier falls through internal gear (pos. 13, page 21). Check that carrier is fully home on bearing for turbine shaft (pos. 3) in body: Rotate carrier assembly by hand a few rotations to check correct position and function.
4. Mount impeller (pos. 5) on turbine shaft (pos. 2) and secure with circlip (pos. 4).
5. Insert turbine shaft with impeller through carrier assembly. Rotate impeller to ensure correct insertion into bearing for turbine shaft (pos. 3) in body. Check unrestricted rotation.
6. Mount cone (pos. 1) over turbine shaft and retaining ring. Mount and tighten screws (pos. 8) with socket wrench (tool no. 462A).

**Note:** The two planet wheels are different: on planet wheel 1, teeth of upper and lower gearing are aligned, while they are displaced  $\frac{1}{2}$  tooth on planet wheel 2.

Assembly of Turbine and Carrier

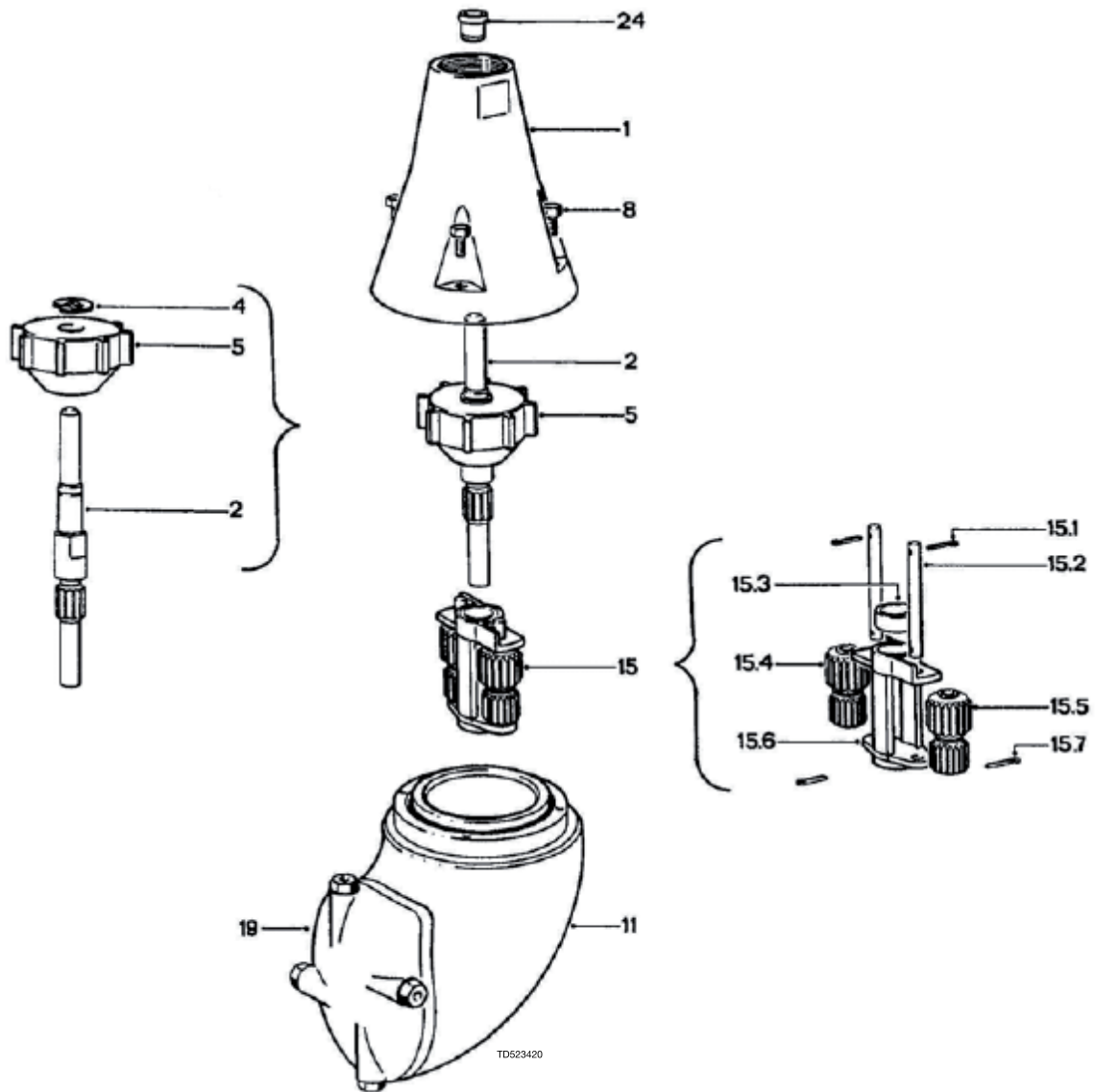

## 6 Maintenance

---

---

---

### 6.4 Remaining assemblies

---

#### Disassembly

1. Remove retainer spring (pos. 6). Use small screwdriver to lift retainer spring out of groove in stem (pos. 16). Lift off retaining ring (pos. 7).
2. Hold body against table and unscrew stem nut w. ball race (pos. 9) with caliper (tool no. 369). Withdraw stem (pos. 16) together with ball retainer w. balls (pos. 10).
3. Remove M5 screws (pos. 12) with a socket wrench (tool no. 462A) and draw out internal gear (pos. 13).
4. Insert a 13 mm spanner (tool no. 81B041) into body, hold cap nut (pos. 23) and by hand screw off hub cover (pos. 19), and remove washer (pos. 22).
5. Hold body against table and unscrew hub nut with ball race (pos. 18) with caliper (tool no. 369). Withdraw hub (pos. 17) together with ball retainer with balls (pos. 10).
6. With screwdriver lift slide bearing (pos. 14) and bearing for turbine shaft (pos. 3) out of body.
7. Unscrew nozzles (pos. 21) with 11 mm spanner (tool no. 81B041). Be careful not to damage nozzle vanes (pos. 20) as this will severely reduce nozzle performance. Nozzle vanes should not be removed unless they need to be replaced.

If ball races (pos. 16.2 and 17.2) on stem and hub as well as stem/hub nut with ball race (pos. 9 and 18) are heavily worn, they should be replaced as well as ball retainer with balls (pos. 10), see page 24.

**Note:** Left-hand thread

#### Reassembly

Before reassembly make sure that all parts are clean without deposits or build-up of foreign matter.

1. If necessary insert new nozzle vanes (pos. 20, see drawing page 21). Be careful not to damage nozzle vanes. Mount nozzles (pos. 21) and tighten with spanner.
2. Place slide bearing (pos. 14) in body and push in bearing for turbine shaft (pos. 3) with thumb. Make sure that bearing is fully home.
3. Inset hub (pos. 17) together with ball retainer with balls (pos. 10). Mount hub nut with ball race (pos. 18) with caliper (tool no. 369) and tighten.
4. Place washer (pos. 22) on threaded pin on hub cover and mount cap nut (pos. 23). Insert spanner (tool no. 81B041) into body, hold cap nut (pos. 23) and by hand screw on hub cover (pos. 19) and tighten. Check free rotation of hub.
5. Insert internal gear (pos. 13), mount screws (pos. 12) and tighten with socket wrench (tool no. 462A).
6. Insert stem (pos. 16) together with ball retainer with balls (pos. 10). Mount stem nut with ball race (pos. 9) with caliper (tool no. 369) and tighten. Turn hub cover and check unrestricted rotation.
7. Place retaining ring (pos. 7) over stem (pos. 16) and push on retainer spring (pos. 6) and "click" into groove in stem. Check free rotation.

**Note:** Left-hand thread



## 6 Maintenance

---

### 6.5 Replacement of ball races

---

1. Place stem or hub complete (pos. 16 or 17) in a support ring and press off ball race. Press parallel. Use press or vice. Be careful not to damage teeth and opposite end face of stem.
2. With mandrel press ball race fully home. Press parallel. Use press or vice. Be careful not to damage surface of ball race.

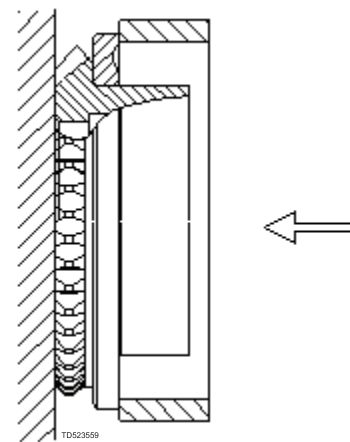
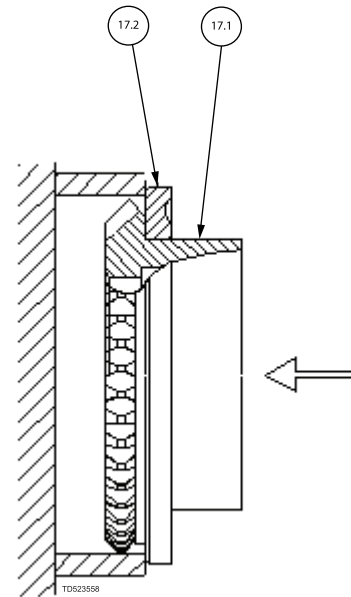



---

**Symptom: Slow or no rotation of machine**

Possible Causes	Fault finding
<b>No or insufficient liquid flow</b>	a). Check if supply valve is fully open. b). Check if inlet pressure to mixer is correct. c). Check supply line/filter for restrictions/clogging. d). Remove nozzles and check for clogging. If blocked, carefully clean nozzle without damaging nozzle vanes and nozzle tip. e). Remove cone, guide and impeller and check for clogging in impeller area. f). If large particles repeatedly get jammed in the mixer, install filter or reduce mesh size of installed filter in supply line.
<b>Foreign material or material build-up</b>	Insert Hex screwdriver in screw in top of turbine shaft and easily turn turbine shaft clockwise. If any resistance is recognised, disassemble machine in order to localise the cause.
a) Impeller jammed	Remove guide and impeller (see page 20) and remove foreign material.
b) Turbine shaft sluggish in main bush	Remove gland (see page 20) and clean main bush.
c) Planet gear jammed/sluggish	Remove foreign material from planet wheels and internal gears. Check rotation of planet wheels. If restriction is recognised, disassemble carrier assembly (see page 20) and remove material build up, especially on shafts and bushes in planet wheels.
d) Stem or hub jammed/sluggish	Remove carrier assembly (see page 20). Turn hub cover and check unrestricted rotation. Remove stem and hub (see page 22). Remove foreign material/material build-up on stem, hub and inside nut with ball race. Clean ball races and ball retainer with balls. Assemble stem/hub, ball retainer with balls and stem/hub nut with ball race. Also clean main bush.
e) Bevel gears jammed	Remove flange/nipple and hub (see page 22). Clean teeth on stem and hub.
<b>Wear</b>	
a) Slide bearings	See page 17
b) Bearing for turbine shaft	See page 17
c) Planet wheels	See page 17
d) Shafts for planet wheels	Check clearance of planet wheels on shafts. Transverse movement should not exceed 0.3 mm.
e) Turbine shaft	Check clearance in carrier bearing and bearing for turbine shaft. Transverse movement should not exceed 0.3 mm. Also inspect teeth for wear.
<b>Mechanical defects</b>	
a) Planet wheels. Teeth broken	Replace planet wheels.
b) Planet wheel can not rotate on shafts/shafts bent.	Replace shafts for planet wheels.
c) Damaged teeth on bevel gear	Inspect teeth on stem and hub for deformation. Mount hub and stem in body (See page 22). Hold body in upside down position and rotate Hub to check that bevel gears can work together. If damaged: Replace stem and/or hub.

---

## 8 Technical data

Weight of machine:	5.1 kg (11.2 lbs)
Working pressure:	3-8 bar (40-115 psi)
Recommended inlet pressure:	5-7 bar (70-100 psi)
Working temperature max.:	110°C (230°F)
Max. temperature:	140°C (284°F) - steam pressure = 2.5 bar
Materials:	Stainless Steel, PFA, PEEK, PVDF, A4/EPDM

### Dimensions in mm

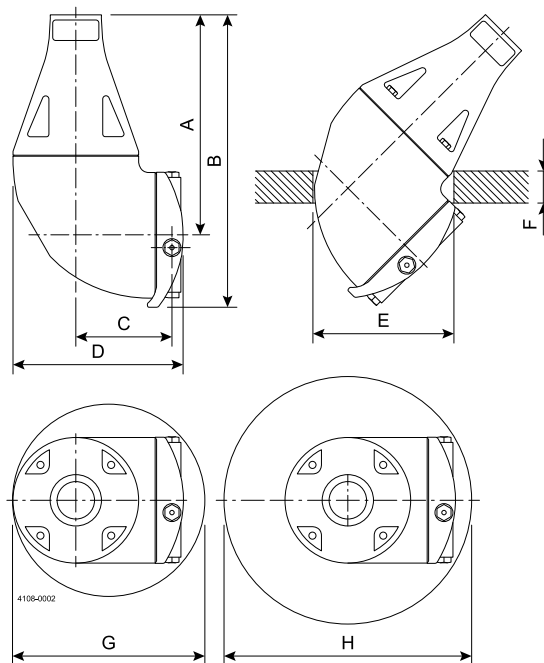

A	B	C	D	E	F	G	H
173	230	75	133	ø110	Max. 25	ø150	ø200

Minimum required passage: ø110 mm (4.33 inch) at flange thickness 25 mm (0.98 inch). Otherwise ø150 mm (5.90 inch)

**Performance Data**

Flow rate m<sup>3</sup>/h

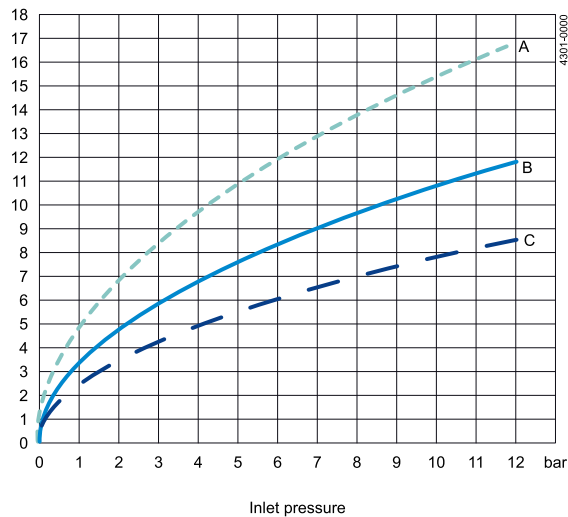

A = Nozzle d = 5.5 mm  
 B = Nozzle d = 4.6 mm  
 C = Nozzle d = 3.9 mm

Inlet pressure (bar)

Nozzles A) d = 5.5 mm  
 B) d = 4.6 mm  
 C) d = 3.9 mm

Throw length (m)

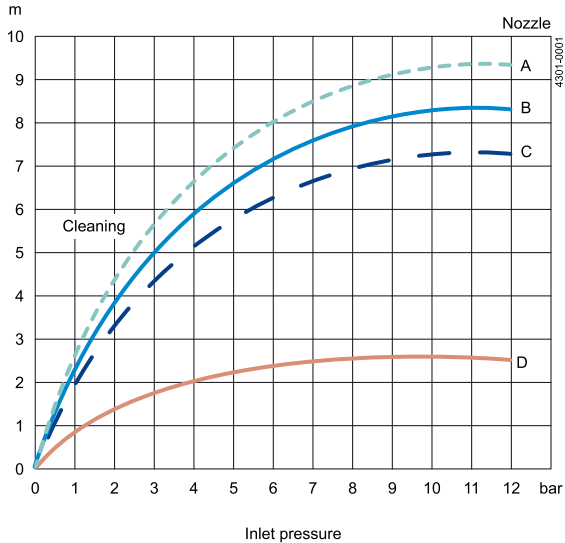

A = d = 5.5 mm D = Mixing  
 B = d = 4.6 mm  
 C = d = 3.9 mm

Inlet pressure (bar)

Nozzles A) d = 5.5 mm D) Cleaning  
 B) d = 4.6 mm E) Mixing  
 C) d = 3.9 mm

Min. RPM of machine body

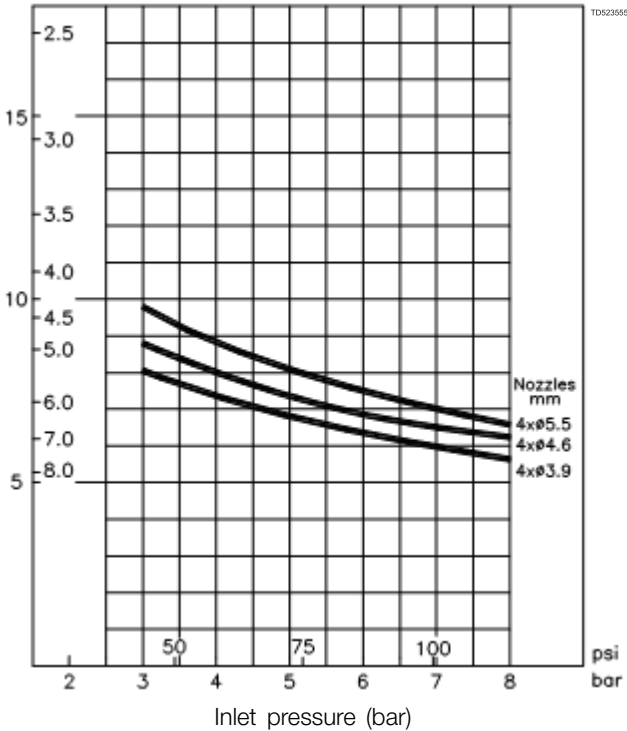

**Note:**  
 The distance (reach) of the jet from the rotary nozzles at which the jets still have a reasonable mixing effect depends i.a. of pressure, the diameter of the nozzles, the viscosity of the fluid, the desired mixing time and various other parameters.

The effective reach of the jets as indicated above is in a fluid with a viscosity of 1 cP.

The pressure is measured at the mixer. This means that due consideration shall be taken to pressure drops in the recirculation line from the pump to the mixer as well as to static pressure differences, when the jet mixing system is being dimensioned.

## 9 Product programme

---

### 9.1 Standard configuration for Alfa Laval Rotary Jet Mixer IM 10

---

Connection	Nozzles (mm)	Article No.
1" BSP, Female	4 x ø3.9	TE30B030
	4 x ø4.6	TE30B040
	4 x ø5.5	TE30B050
1" NPT, Female	4 x ø3.9	TE30N030
	4 x ø4.6	TE30N040
	4 x ø5.5	TE30N050

9.2 Available add-ons

Welding adapter with sealing assembly between down pipe, welding adapter and machine.

Pipe Dimension in mm	Connection thread	Article No.
1" ISO thread pipe: $\phi 33.7 \times 3.25$	1" BSP	TE52D030
1" ANSI Sch.40S: $\phi 33.4 \times 3.38$	1" NPT	TE52D031
1½" ISO Dairy pipe: $\phi 38 \times 1.2$	1" BSP	TE52D032

For devices with tapered thread connections to the down pipe, it is recommended that you secure the connection in a manner appropriate for the application. Subject to the intended use environment and any in-house user requirements or policies, an adhesive such as Loctite No. 243 or equivalent could be used. Other methods could be acceptable and subject to customer preference.

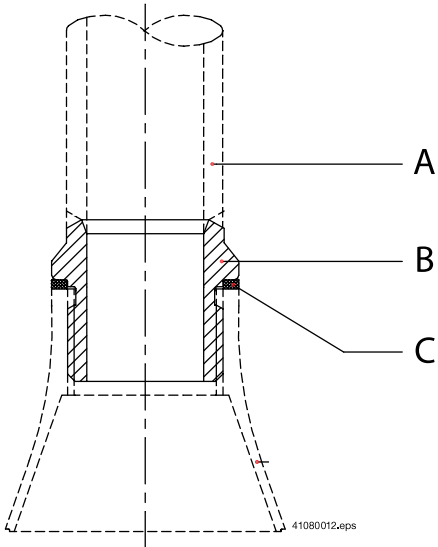

A: Down pipe  
 B: Welding adapter  
 C: Seal PTFE

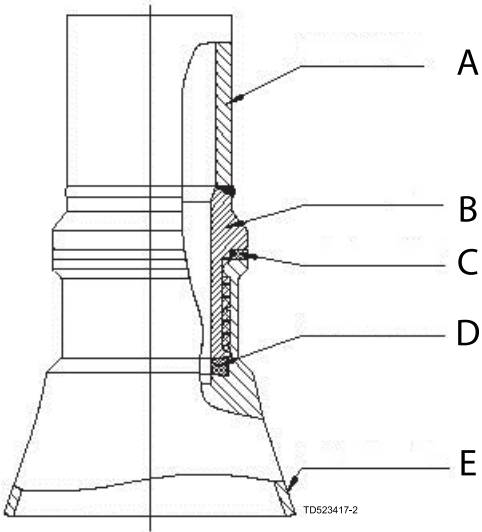

A: Down pipe  
 B: Welding adapter  
 C: Seal PTFE  
 D: Seal EPDM  
 E: IM-10

# 10 Parts list and drawing, service kit and tools

## 10.1 Alfa Laval Rotary Jet Mixer IM 10

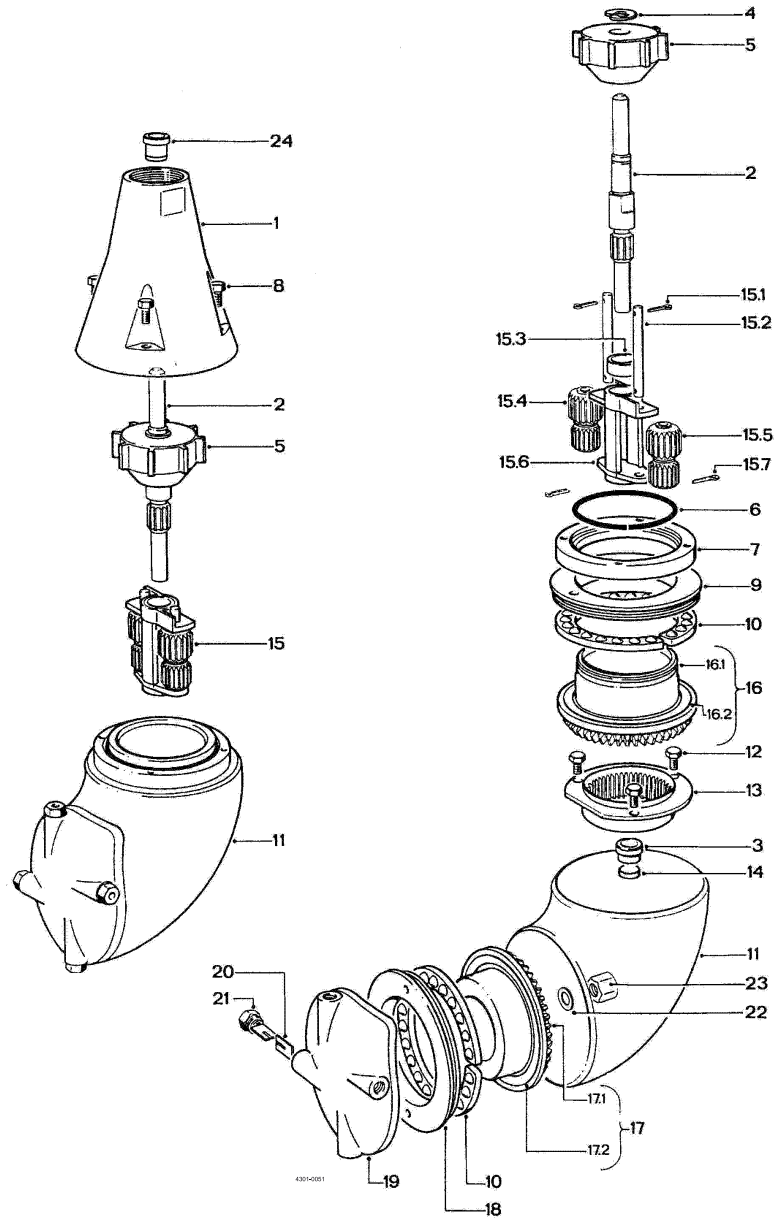

## 10 Parts list and drawing, service kit and tools

### Parts list

Pos.	Qty	Denomination
1	1	Cone 1" BSP
2	1	Turbine shaft
3 ♦	1	Bearing for turbine shaft (body)
4	1	Circlip RS 10, DIN 6799
5 □	1	Impeller
6	1	Retainer spring
7	1	Retaining ring
8	4	Screw
9 ♦	1	Stem nut with ball race
10 ♦	2	Ball retainer with balls
11	1	Body
12	3	Screw
13	1	Internal gear
14 ♦	1	Slide bearing
15	1	Planet complete
15.1 ♦	2	Cotter pin
15.2	2	Shaft for Planet wheel
15.3 ♦	1	Bearing for Planet wheel carrier
15.4 ♦	1	Planet wheel I
15.5 ♦	1	Planet wheel II
15.6	1	Planet gear carrier
15.7	2	Cotter pin (=15.1)
16	1	Stem complete
16.1	1	Stem
16.2 ♦	1	Ball race
17	1	Hub complete
17.1	1	Hub
17.2	1	Ball race (= 16.2)
18 ♦	1	Hub nut with ball race
19 □	1	Hub cover with pin
20	8	Nozzle vane
21 □	4	Nozzle
22 ♦	1	Washer, USIT
23	1	Cap nut
24 ♦	1	Bearing for turbine shaft (cone)

### Service kits

Denomination

#### Service kit

Service kit for Alfa Laval IM 10..... TE30B292

Configuration according to delivery note/order.

Parts marked with ♦ are included in the Service Kit for Alfa Laval IM 10: TE30B292

## 10 Parts list and drawing, service kit and tools

---

### 10.2 Tools

---

Standard Tool Kit, Article no. TE81B085

Item no.	Denomination
369	5 mm caliper
462A	8 mm socket wrench with pin
81B040	Spanner, 36 mm
81B041	Spanner, 12/13 mm

---



### 11.1 Service & repair

---

Upon every return of a product, no matter if for modifications or repair, it is necessary to contact your local Alfa Laval office to guarantee a quick execution of your request.

You will receive instructions regarding the return procedure from your local Alfa Laval office. Be sure to follow the instructions closely.

### 11.2 How to order spare parts

---

On the Cross Sectional Drawings as well as on all instruction drawings, the individual parts have a pos. no., which is the same on all drawings. From the pos. No. the part is easily identified in the Reference List of Parts, page 30.

Individual parts should always be ordered from the Reference List of Parts, page 30. Ref. No. and description should be clearly stated.

Please also quote the type of machine and serial No. This will help us to help you. The type and serial Nos. are stamped on the Connection Nipple on the top of the tank cleaning machine.

### 11.3 How to contact Alfa Laval Kolding A/S

---

For further information please feel free to contact:

**Alfa Laval Kolding A/S**

31, Albuen - DK 6000 Kolding - Denmark

Registration number: 30938011

Tel switchboard: +45 79 32 22 00 - Fax switchboard: +45 79 32 25 80

[www.toftejorg.com](http://www.toftejorg.com), [www.alfalaval.dk](http://www.alfalaval.dk) - [info.dk@alfalaval.com](mailto:info.dk@alfalaval.com)

Contact details for all countries are continually updated on our websites

---

**How to contact Alfa Laval**

Contact details for all countries are continually updated on our website.

Please visit [www.alfalaval.com](http://www.alfalaval.com) to access the information directly.

© Alfa Laval Corporate AB

This document and its contents is owned by Alfa Laval Corporate AB and protected by laws governing intellectual property and thereto related rights. It is the responsibility of the user of this document to comply with all applicable intellectual property laws. Without limiting any rights related to this document, no part of this document may be copied, reproduced or transmitted in any form or by any means (electronic, mechanical, photocopying, recording, or otherwise), or for any purpose, without the expressed permission of Alfa Laval Corporate AB. Alfa Laval Corporate AB will enforce its rights related to this document to the fullest extent of the law, including the seeking of criminal prosecution.