

Homogenizer HST - HLE11

- Standard capacity 7 gal/min
- Standard homogenizer pressure 2,901 PSI
- Absorbed motor power: 15 hp
- Aseptic execution is optional
- Sustainable for processing high viscosity products
- Unique design in accordance with the conditions is use simple installation, economic design, and easy maintenance



Weight with motor: Approx. 1,764 lbs
 Technical changes reserved!

Model	Max. Capacity	Max. Pressure
HST-HLE11	GPM	PSI
HLE11-180	9	2,611
HLE11-200	7	2,901
HLE11-300	4	4,351
HLE11-400	3	5,802
HLE11-500	2	7,252
HLE11-750	1	10,878
HLE11-1000	.7	14,504

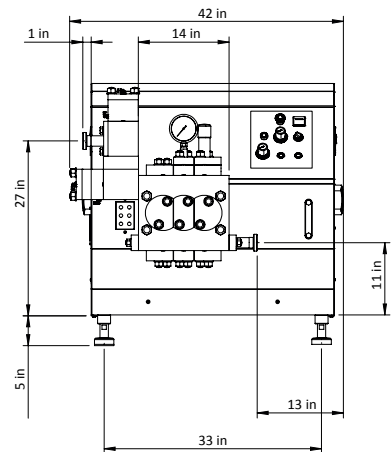

Model	Max. Speed	Max. Diameter
HST-HLE11	RPM (Speed)	MM (Diameter)
HLE11-180	135	40
HLE11-200	135	35
HLE11-300	126	30
HLE11-400	135	25
HLE11-500	135	20
HLE11-750	100	20
HLE11-1000	100	16

