

Homogenizer HST - HLE18.5

- Standard capacity 11 gal/min
- Standard homogenizer pressure 2,901 PSI
- Absorbed motor power: 25 hp
- Aseptic execution is optional
- Sustainable for processing high viscosity products
- Unique design in accordance with the conditions is use simple installation, economic design, and easy maintenance

Weight with motor: Approx. 2,425 lbs
 Technical changes reserved!



Model	Max. Capacity	Max. Pressure
HST-HLE18.5	GPM	PSI
HLE18.5-120	18	1,740
HLE18.5-170	13	2,466
HLE18.5-200	11	2,901
HLE18.5-250	9	3,626
HLE18.5-300	7	4,351
HLE18.5-400	6	5,802
HLE18.5-500	4	7,252
HLE18.5-600	3	8,702
HLE18.5-750	2	10,878
HLE18.5-1000	2	14,504

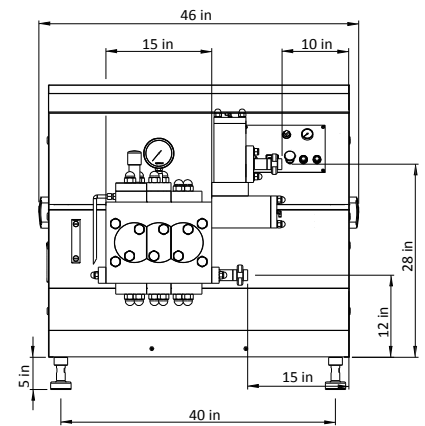

Model	Max. Speed	Max. Diameter
HST-HLE18.5	RPM (Speed)	MM (Diameter)
HLE18.5-120	160	55
HLE18.5-170	160	50
HLE18.5-200	165	45
HLE18.5-250	140	45
HLE18.5-300	122	40
HLE18.5-400	122	35
HLE18.5-500	120	30
HLE18.5-600	120	25
HLE18.5-750	120	20
HLE18.5-1000	120	16

