

# Homogenizer HST - HLE30

- Standard capacity 15 gal/min
- Standard homogenizer pressure 2,901 PSI
- Absorbed motor power: 40 hp
- Aseptic execution is optional
- Sustainable for processing high viscosity products
- Unique design in accordance with the conditions of use simple installation, economic design, and easy maintenance

Weight with motor: Approx. 2,425 lbs  
 Technical changes reserved!



Model	Max. Capacity	Max. Pressure
HST-HLE30	GPM	PSI
HLE30-120	24	1,740
HLE30-170	19	2,466
HLE30-200	15	2,901
HLE30-250	13	3,626
HLE30-300	10	4,351
HLE30-400	7	5,802
HLE30-500	5	7,252
HLE30-600	4	8,702
HLE30-750	3	10,878
HLE30-1000	2	14,504

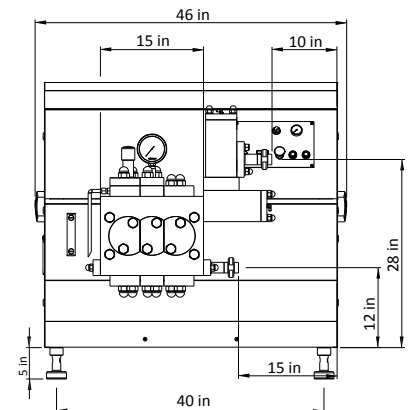

Model	Max. Speed	Max. Diameter
HST-HLE30	RPM (Speed)	MM (Diameter)
HLE30-120	163	55
HLE30-170	163	50
HLE30-200	170	45
HLE30-250	145	45
HLE30-300	128	40
HLE30-400	128	35
HLE30-500	122	30
HLE30-600	122	25
HLE30-750	122	20
HLE30-1000	122	16

