

Homogenizer HST - HLE37

- Standard capacity 22 gal/min
- Standard homogenizer pressure 2,901 PSI
- Absorbed motor power: 50 hp
- Aseptic execution is optional
- Sustainable for processing high viscosity products
- Unique design in accordance with the conditions of use simple installation, economic design, and easy maintenance

Weight with motor: Approx. 3,968 lbs
 Technical changes reserved!

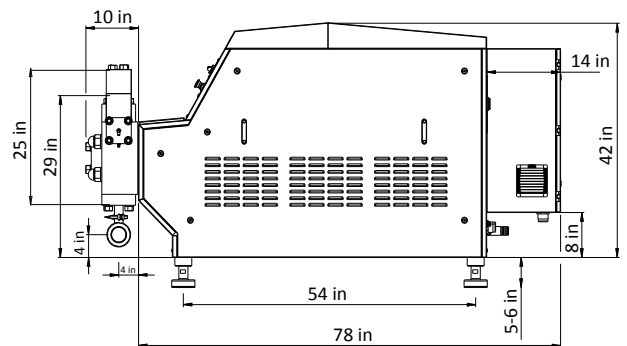
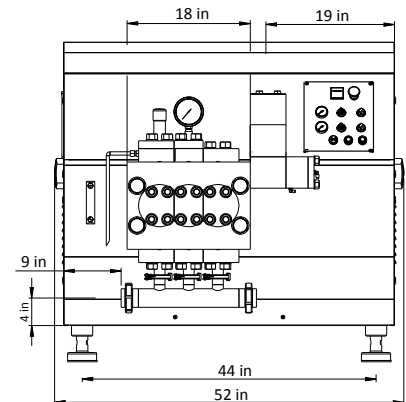

Model	Max. Capacity	Max. Pressure
HST-HLE37	GPM	PSI
HLE37-130	31	1,885
HLE37-170	26	2,466
HLE37-200	22	2,901
HLE37-250	18	3,626
HLE37-300	13	4,351
HLE37-400	11	5,802
HLE37-500	7	7,252
HLE37-750	4	10,878
HLE37-1000	3	14,504

Model	Max. Speed	Max. Diameter
HST-HLE37	RPM (Speed)	MM (Diameter)
HLE37-130	123	70
HLE37-170	145	60
HLE37-200	123	60
HLE37-250	116	55
HLE37-300	123	50
HLE37-400	129	45
HLE37-500	123	35
HLE37-750	123	30
HLE37-1000	123	20

