

# Homogenizer HST - HLE75

- Standard capacity 44 gal/min
- Standard homogenizer pressure 2,901 PSI
- Absorbed motor power: 101 hp
- Aseptic execution is optional
- Sustainable for processing high viscosity products
- Unique design in accordance with the conditions of use simple installation, economic design, and easy maintenance

Weight with motor: Approx. 6,173 lbs  
 Technical changes reserved!

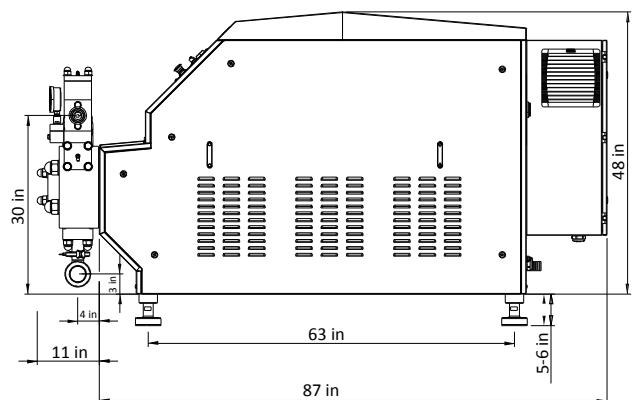
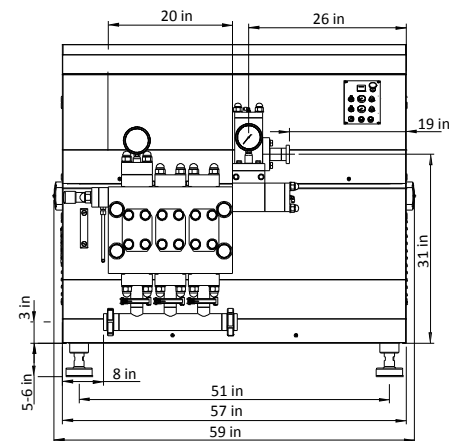

Model	Max. Capacity	Max. Pressure
HST-HLE75	GPM	PSI
HLE75-150	55	2,176
HLE75-200	44	2,901
HLE75-250	35	3,626
HLE75-300	26	4,351
HLE75-350	22	5,076
HLE75-400	18	5,802
HLE75-500	13	7,252
HLE75-600	11	8,702
HLE75-750	9	10,878
HLE75-850	7	12,328
HLE75-1000	4	14,504

Model	Max. Speed	Max. Diameter
HST-HLE75	RPM (Speed)	MM (Diameter)
HLE75-150	135	90
HLE75-200	135	80
HLE75-250	128	70
HLE75-300	135	60
HLE75-350	122	60
HLE75-400	105	40
HLE75-500	108	45
HLE75-600	114	40
HLE75-750	114	35
HLE75-850	101	30
HLE75-1000	107	25

