

Homogenizer HLI90

- Max. 70 (gal/min)
- Max. Homogenizing pressure up to 10,153 PSI
- Poppet valve and ball valve execution
- Max. motor power: 101 hp
- Weight with motor approx. 5,842 lbs
- Customized execution
- Control cabinet incl. PCL control
- Optional in aseptic execution with sterile water unit
- Integrated lubrication system
- Lower ecological footprint
- Designed and made in Germany



Technical changes reserved!

Poppet valves

For low viscosity and slightly abrasive products

Model	Max. Pressure (PSI)	Max. Capacity (GPM)
HLI75-100T	1,450	70
HLI75-150T	2,176	70
HLI75-200T	2,901	55
HLI75-250T	3,626	41
HLI75-300T	4,351	33
HLI75-350T	5,076	28
HLI75-550T	7,977	18

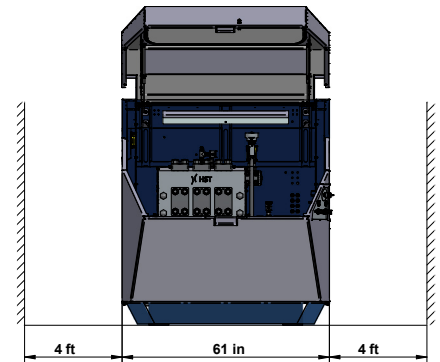

Ball valves

For high viscosity and abrasive products

Model	Max. Pressure (PSI)	Max. Capacity (GPM)
HLI75-150K	2,176	63
HLI75-200K	2,901	48
HLI75-300K	4,351	29
HLI75-400K	5,802	24
HLI75-550K	7,977	15
HLI75-700K	10,153	11

