

Laboratory Homogenizer HLL0

The homogenization process for new products begins in the laboratory facility. The new bench top homogenizer HLL0 enables the first step for a successful homogenization and will grant you an excellent scale up of the achieved results. The HLL0 can be driven either as stand-alone unit or integrated in mini-plants for various sanitary or aseptic installation.

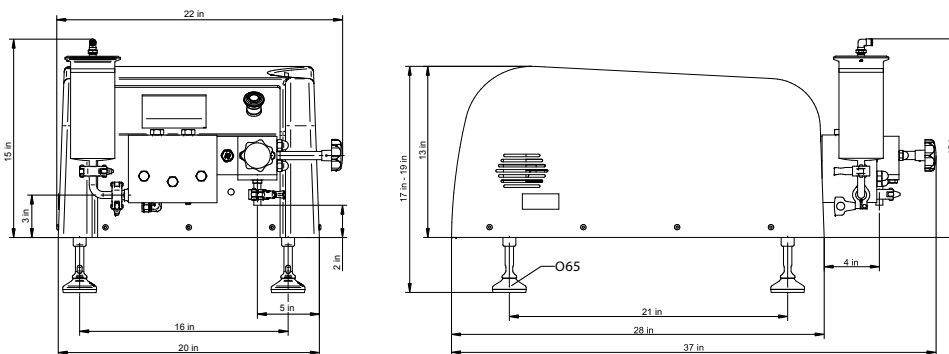

TECHNICAL DATA

- Universal 2-plunger homogenizer with special camshaft characteristic
- .04 gpm capacity at max. 22 psi total pressure
- Suitable for sanitary and aseptic conditions
- 2-stage homogenization valve in material tungsten carbide for a broad range of application
- Process connections: ½" Triclamp
- 1 Liter inlet vessel with pressure connection for pumping support
- Min. batch size: approx. 8 oz
- Electrical execution: 1,1 hp motor , HMI touch panel, network connection, cable, plug
- Weight: approx. 353 lbs.

Technical changes reserved