

Ampco Centrifugal Pumps

DATA SHEET

MODEL ZC2 1½ X 1¼
NICKEL ALUMINUM BRONZE

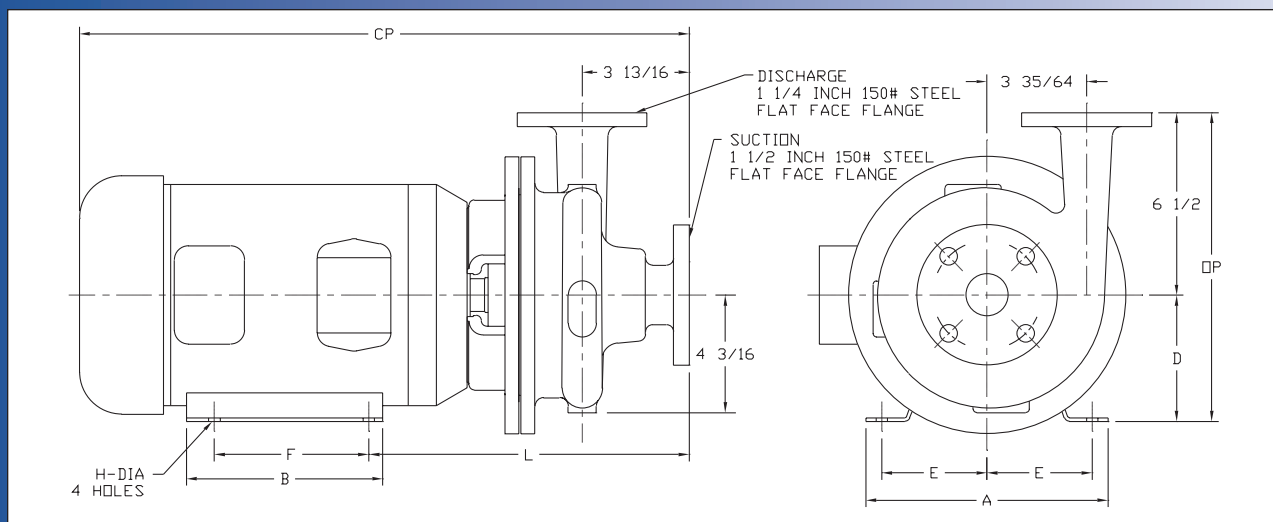

X	TEFC MOTOR			DIMENSIONS IN INCHES (For Reference Only)								APPROX. WEIGHT (LBS)	
	HP	RPM	FRAME	A	B	D	E	F	H	L	CP		OP
	1	1750	143JM	6-1/2	6	3-1/2	2-3/4	4	11/32	10-7/8	19-3/16	10	110
	1-1/2	1750	145JM	6-1/2	6	3-1/2	2-3/4	5	11/32	10-7/8	19-3/16	10	114
	2	1750	145JM	6-1/2	6	3-1/2	2-3/4	5	11/32	10-7/8	19-3/16	10	120
	2	3500	145JM	6-1/2	6	3-1/2	2-3/4	5	11/32	10-7/8	19-3/16	10	120
	3	3500	145JM	6-1/2	6	3-1/2	2-3/4	5	11/32	10-7/8	19-3/16	10	146
	5	3500	184JM	8-5/8	6-1/2	4-1/2	3-3/4	5-1/2	13/32	11-1/2	22	11	159
	7-1/2	3500	213JM	9-5/8	8-1/8	5-1/4	4-1/4	5-1/2	13/32	12-7/16	24-3/4	11-3/4	227

MATERIAL SPECIFICATIONS

PART NAME	NICKEL ALUMINUM BRONZE
Casing, Cover & Impeller	AMPCO® 483
Wear Ring	AMPCO® 18
Motor Shaft	Steel
Shaft Sleeve	AMPCO® 18
Adapter	Cast Iron



Ampco Centrifugal Pumps

**MODEL ZC2 1½ X 1¼
NICKEL ALUMINUM BRONZE**

Curves show approximate characteristics based on clear 68° water. Rated point is guaranteed.

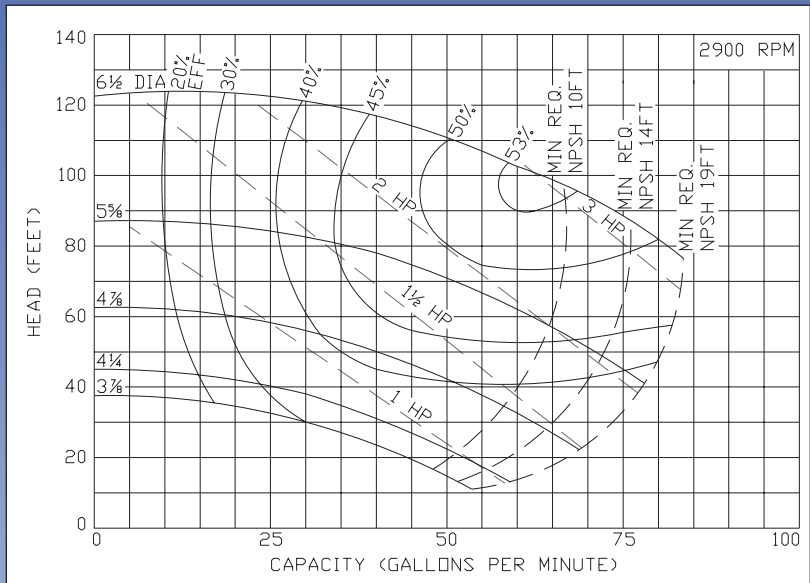
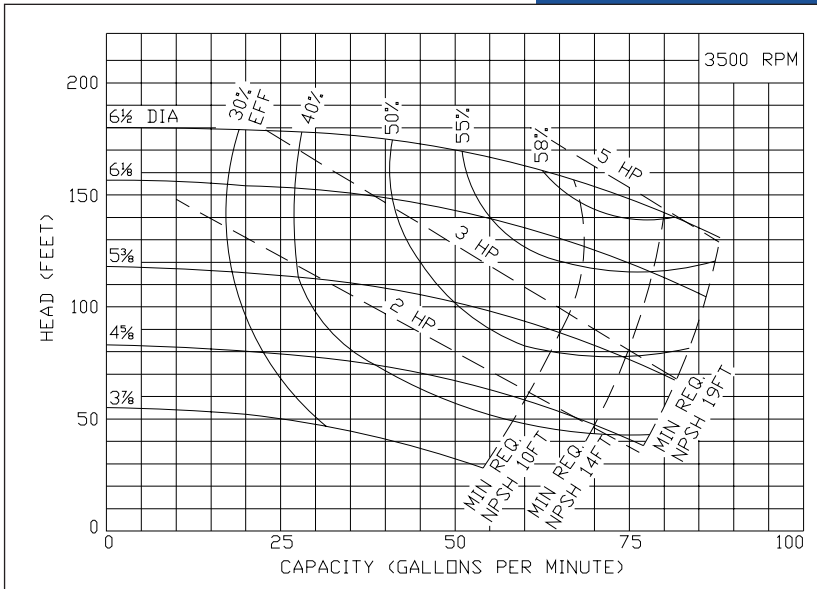

Heavy-duty Z Series pumps have maximum wall thickness and 150 lb. flat faced flanged connections.

Seal options include Type 21, Type 1 and Type 9 with choice of sealing materials.

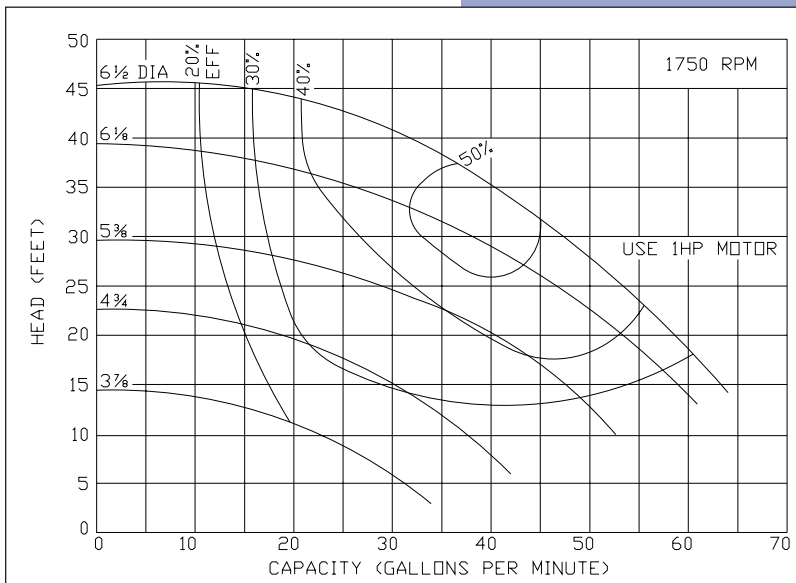

Ampco Pumps Company

4424 West Mitchell Street
Milwaukee, Wisconsin 53214
PHONE (414) 643-1852
FAX (414) 643-4452

Ampco Centrifugal Pumps

DATA SHEET

MODEL ZC2 1½ X 1¼
STAINLESS STEEL

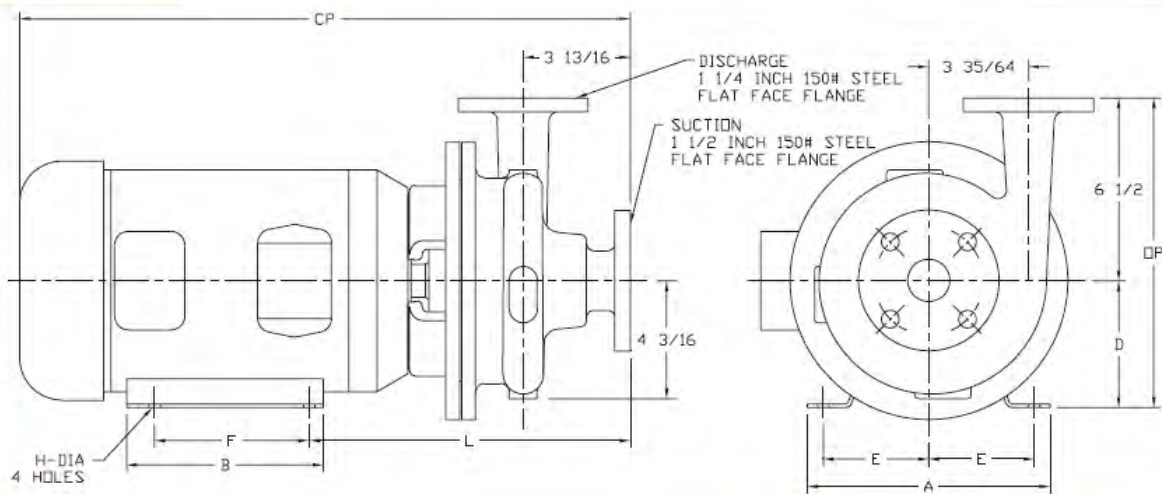

TEFC MOTOR			DIMENSIONS IN INCHES (For Reference Only)									APPROX. WEIGHT (LBS)
HP	RPM	FRAME	A (max)	B (max)	D	E	F	H	L	CP	OP	
1	1750	143JM	6-1/2	6	3-1/2	2-3/4	4	11/32	10-7/8	19-3/16	10	110
1-1/2	1750	145JM	6-1/2	6	3-1/2	2-3/4	5	11/32	10-7/8	19-3/16	10	114
2	1750	145JM	6-1/2	6	3-1/2	2-3/4	5	11/32	10-7/8	19-3/16	10	120
2	3500	145JM	6-1/2	6	3-1/2	2-3/4	5	11/32	10-7/8	19-3/16	10	120
3	3500	145JM	6-1/2	6	3-1/2	2-3/4	5	11/32	10-7/8	19-3/16	10	146
5	3500	184JM	8-5/8	6-1/2	4-1/2	3-3/4	5-1/2	13/32	11-1/2	22	11	159
7-1/2	3500	213JM	9-5/8	8-1/8	5-1/4	4-1/4	5-1/2	13/32	13	25	11-3/4	227

MATERIAL SPECIFICATIONS

PART NAME	STAINLESS STEEL	DUPLEX 2205
Casing, Cover, & Impeller	316 Stainless	Duplex 2205
Wear Ring	316 Stainless	Duplex 2205
Motor Shaft	Steel	Steel
Shaft Sleeve	316 Stainless	Duplex 2205
Adapter	Cast Iron	Cast Iron

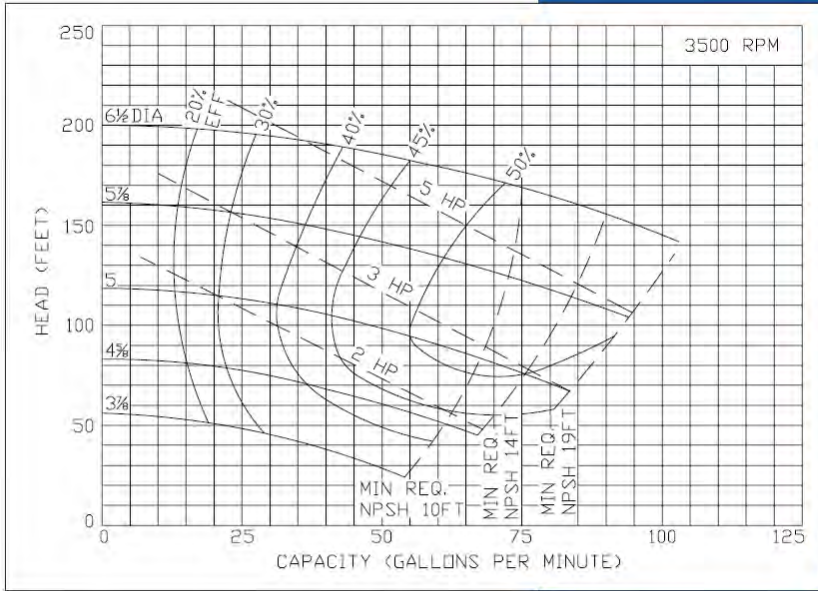

Ampco Centrifugal Pumps

MODEL ZC2 1 1/2 X 1 1/4
STAINLESS STEEL

Curves show approximate characteristics based on clear 68° water. Rated point is guaranteed.

Heavy-duty Z Series pumps have maximum wall thickness and 150 lb. flat faced flanged connections.

Seal options include Type 21, Type 1 and Type 9 with choice of sealing materials.

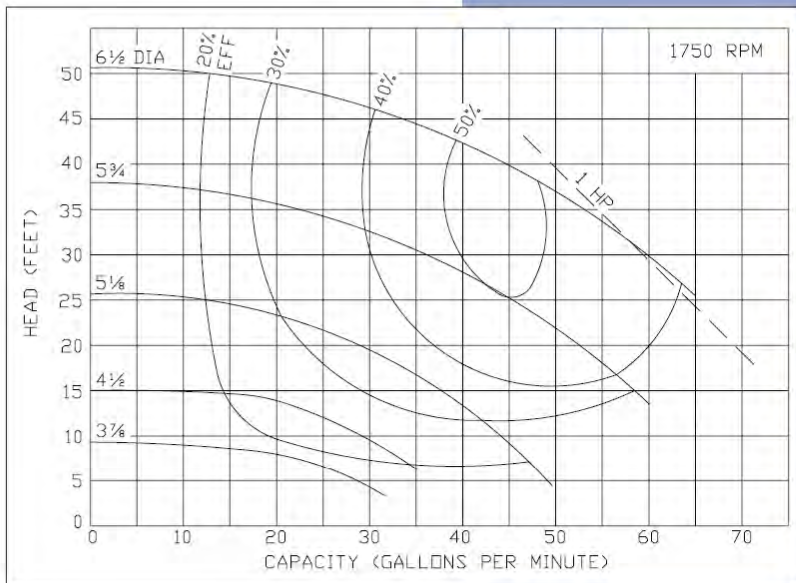
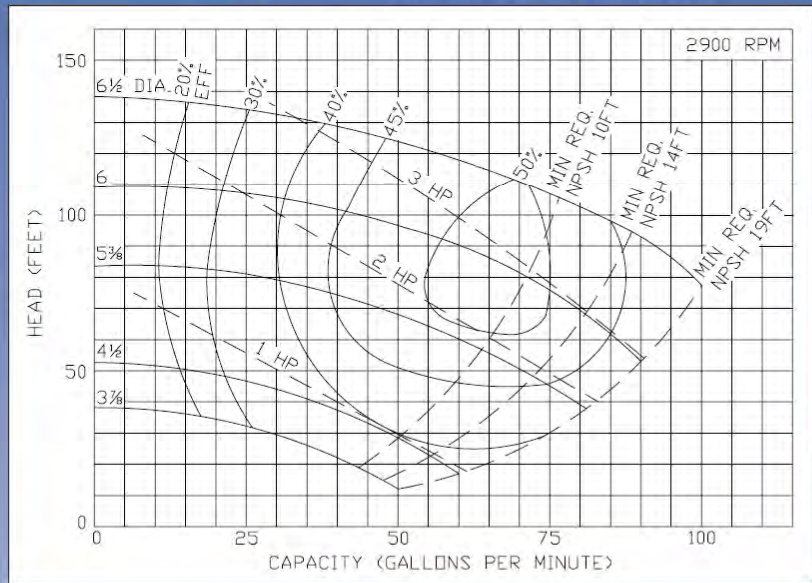

Ampco Pumps Company

4424 West Mitchell Street
Milwaukee, Wisconsin 53214
PHONE (414) 643-1852
FAX (414) 643-4452

Ampco Centrifugal Pumps

DATA SHEET

MODEL ZC2/ZCH2 1 1/2 X 1 1/2

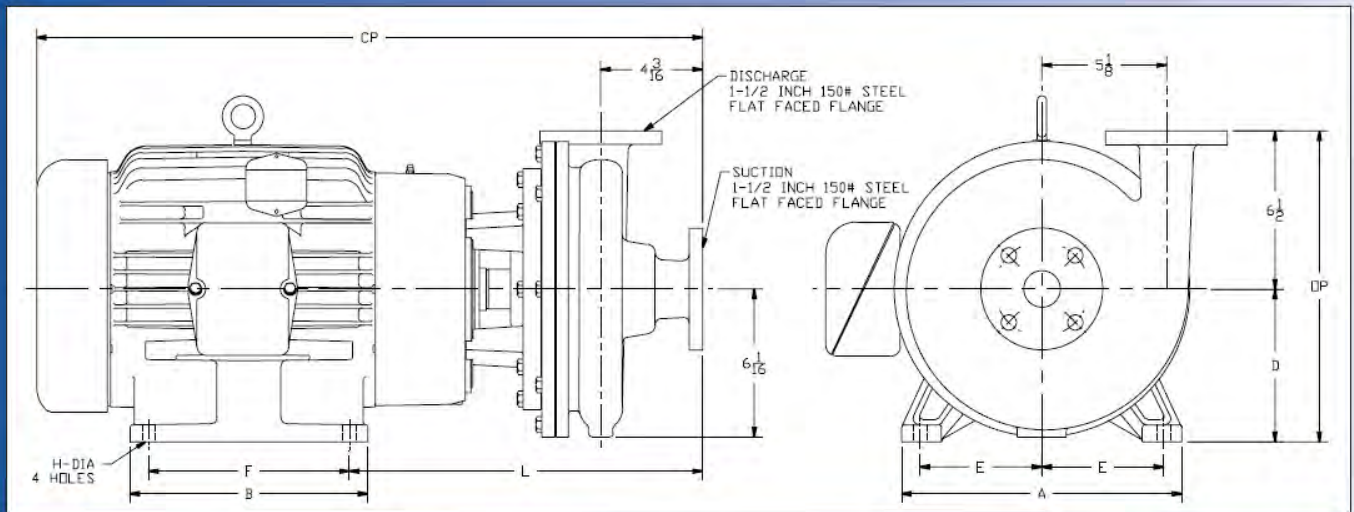

TEFC MOTOR			DIMENSIONS IN INCHES (For Reference Only)									APPROX. WEIGHT (LBS)
HP	RPM	FRAME	A (typ)	B (typ)	D	E	F	H	L	CP	OP	
1	1750	143JM	6-1/2	6	3-1/2	2-3/4	4	11/32	11-3/8	19-11/16	10	135
1-1/2	1750	145JM	6-1/2	6	3-1/2	2-3/4	5	11/32	11-3/8	19-11/16	10	139
2	1750	145JM	6-1/2	6	3-1/2	2-3/4	5	11/32	11-3/8	19-11/16	10	146
3	1750	182JM	8-5/8	6-1/2	4-1/2	3-3/4	4-1/2	13/32	12	21-3/32	11	155
5	3500	184JM	8-5/8	6-1/2	4-1/2	3-3/4	5-1/2	13/32	12	22-7/16	11	189
7-1/2	3500	213JM	9-5/8	8-1/8	5-1/4	4-1/4	5-1/2	13/32	13	25-5/16	11-3/4	257
10	3500	215JM	9-5/8	8-1/8	5-1/4	4-1/4	7	13/32	13	25-5/16	11-3/4	275
15	3500	254JM	11-1/2	9-3/4	6-1/4	5	8-1/4	17/32	14-1/2	27-5/16	12-3/4	389
20	3500	256JM	11-1/2	11-1/2	6-1/4	5	10	17/32	14-1/2	29-3/32	12-3/4	427

MATERIAL SPECIFICATIONS

PART NAME	NICKEL ALUMINUM BRONZE	STAINLESS STEEL	DUPLEX 2205
Casing, Cover, & Impeller	AMPCO® 483	316 Stainless	Duplex 2205
Wear Rings	AMPCO® 18	316 Stainless	Duplex 2205
Motor Shaft	Steel	Steel	Steel
Shaft Sleeve	AMPCO® 18	316 Stainless	Duplex 2205
Adapter	Cast Iron	Cast Iron	Cast Iron

Ampco Centrifugal Pumps

MODEL ZC2/ZCH2 1½X1½

Curves show approximate characteristics based on clear 68° water. Rated point is guaranteed.

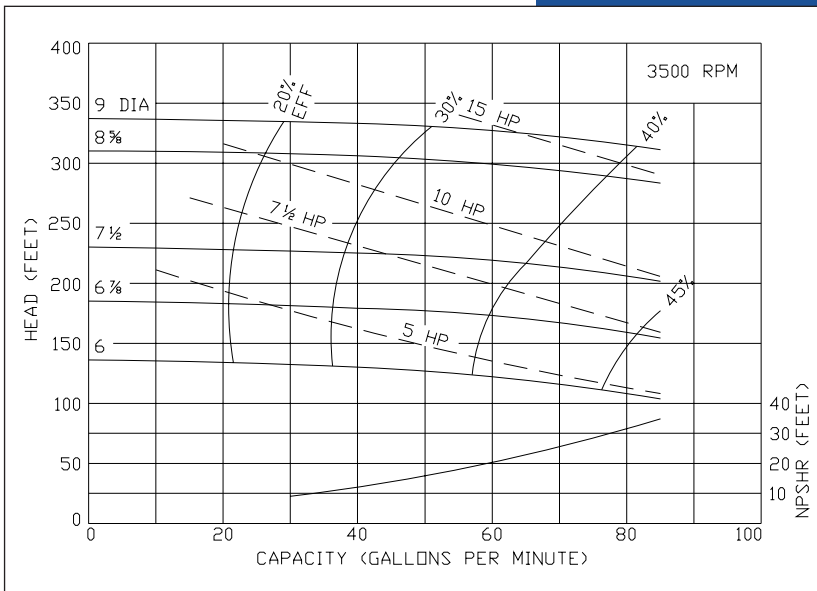

Heavy-duty Z Series pumps have maximum wall thickness and 150 lb. flat faced flanged connections.

Seal options include Type 21, Type 1 and Type 9 with choice of sealing materials.

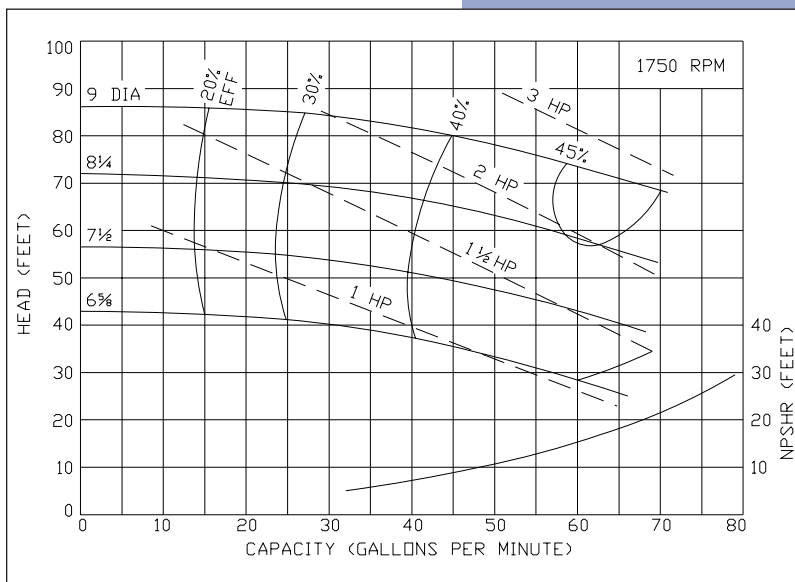
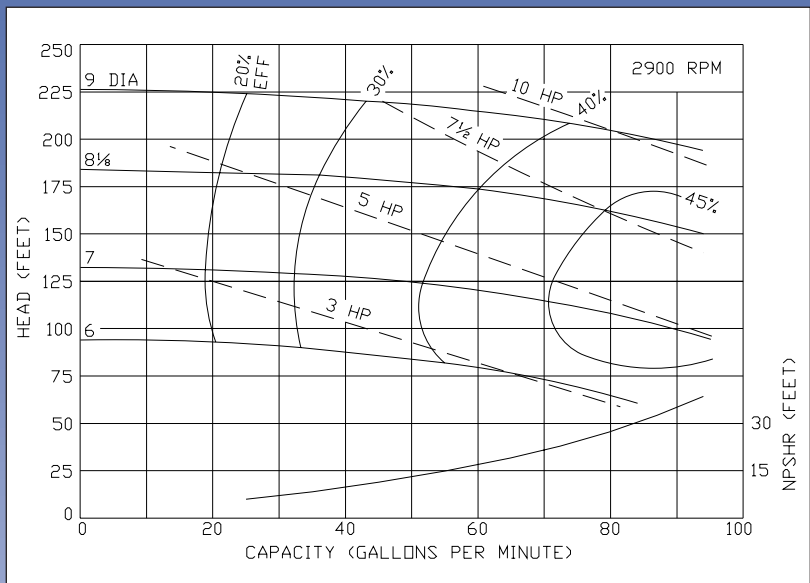

Ampco Pumps Company

4424 West Mitchell Street
 Milwaukee, Wisconsin 53214
 PHONE (414) 643-1852
 FAX (414) 643-4452

Ampco Centrifugal Pumps

DATA SHEET

MODEL ZC2 2 X 1 1/2

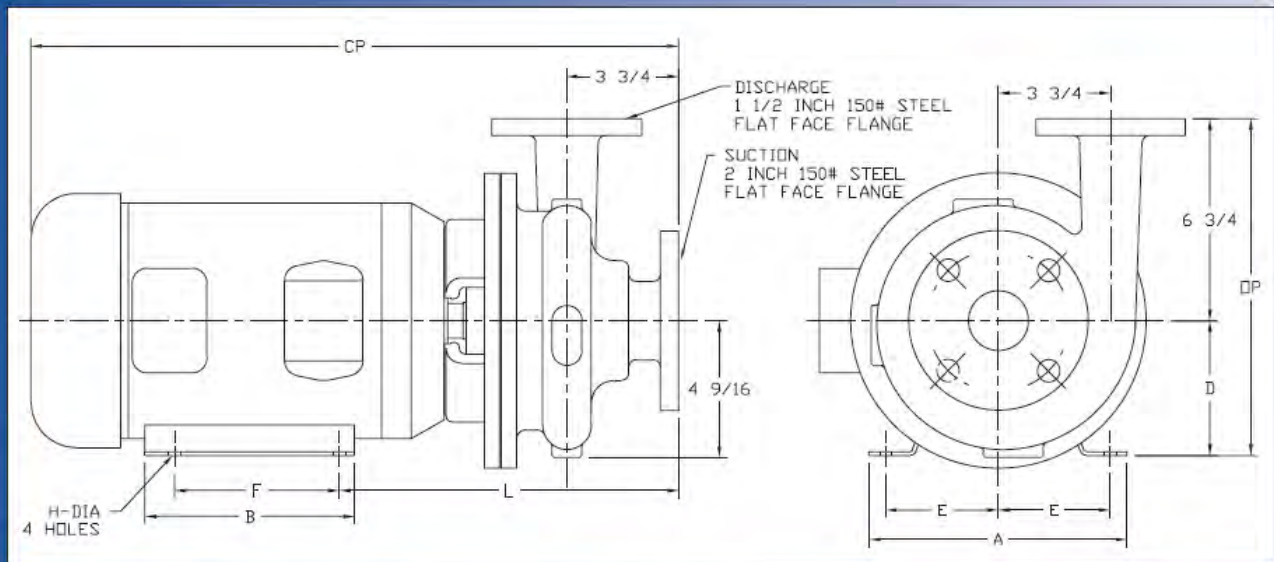

TEFC MOTOR			DIMENSIONS IN INCHES (For Reference Only)									APPROX. WEIGHT (LBS)
HP	RPM	FRAME	A (max)	B (max)	D	E	F	H	L	CP	OP	
1	1750	143JM	6-1/2	6	3-1/2	2-3/4	4	11/32	10-3/16	19-1/8	10-1/4	112
1-1/2	1750	145JM	6-1/2	6	3-1/2	2-3/4	5	11/32	10-3/16	19-1/8	10-1/4	116
2	1750	145JM	6-1/2	6	3-1/2	2-3/4	5	11/32	10-13/16	19-1/8	10-1/4	122
2	3500	145JM	6-1/2	6	3-1/2	2-3/4	5	11/32	10-13/16	19-1/8	10-1/4	122
3	3500	145JM	6-1/2	6	3-1/2	2-3/4	5	11/32	10-13/16	19-1/8	10-1/4	148
5	3500	184JM	8-5/8	6-1/2	4-1/2	3-3/4	5-1/2	13/32	11-7/16	21-15/16	11-1/4	161
7-1/2	3500	213JM	9-5/8	8-1/8	5-1/4	4-1/4	5-1/2	13/32	12-3/16	24-3/4	12	229
10	3500	215JM	9-5/8	8-1/8	5-1/4	4-1/4	7	13/32	12-3/16	24-3/4	12	247

MATERIAL SPECIFICATIONS

PART NAME	NICKEL ALUMINUM BRONZE	STAINLESS STEEL	DUPLEX 2205
Casing, Cover, & Impeller	AMPCO® 483	316 Stainless	Duplex 2205
Wear Ring	AMPCO® 18	316 Stainless	Duplex 2205
Motor Shaft	Steel	Steel	Steel
Shaft Sleeve	AMPCO® 18	316 Stainless	Duplex 2205
Adapter	Cast Iron	Cast Iron	Cast Iron

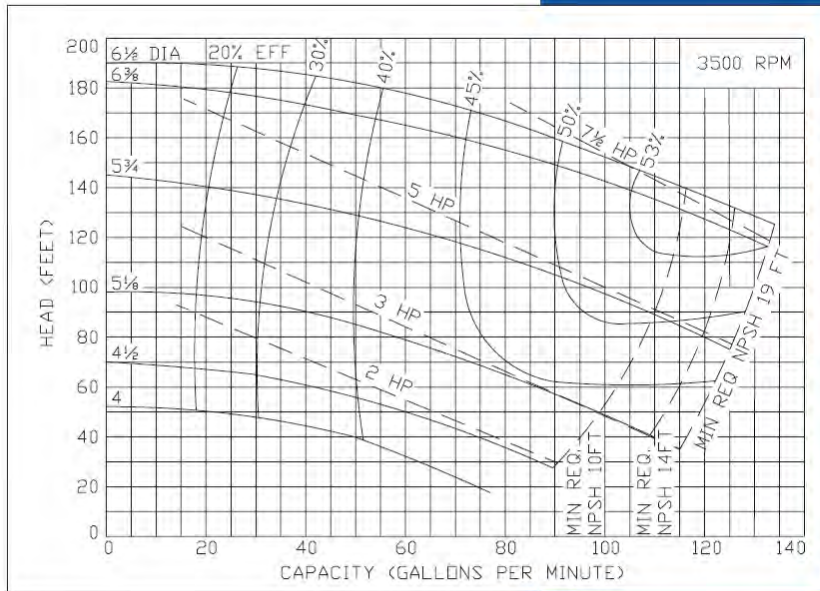

Ampco Centrifugal Pumps

MODEL ZC2 2 X 1 1/2

Curves show approximate characteristics based on clear 68° water. Rated point is guaranteed.

Heavy-duty Z Series pumps have maximum wall thickness and 150 lb. flat faced flanged connections.

Seal options include Type 21, Type 1 and Type 9 with choice of sealing materials.

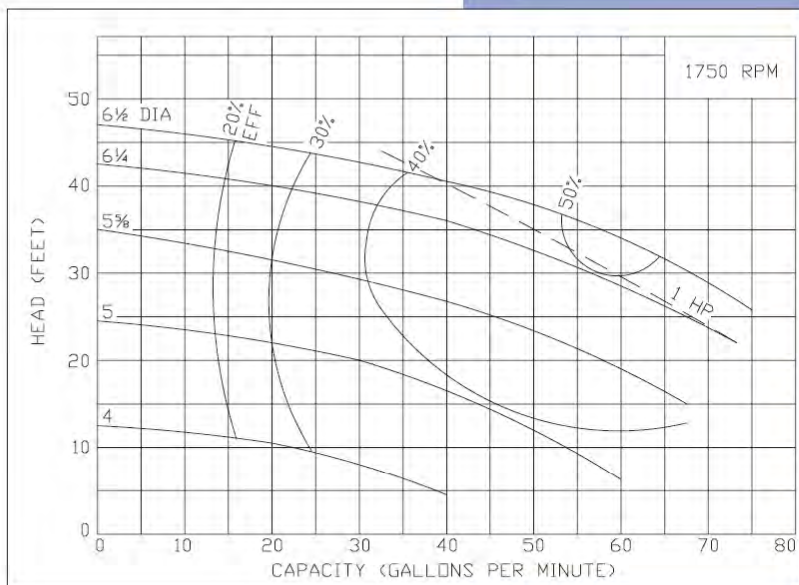
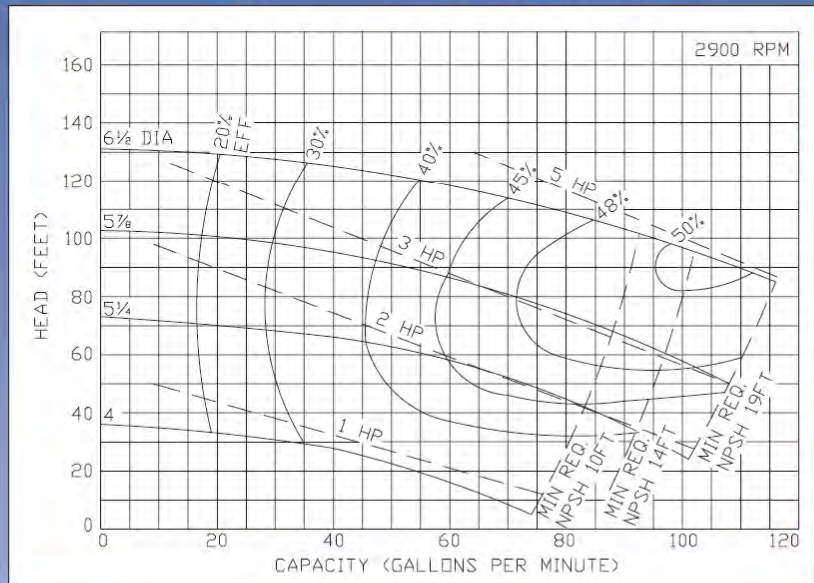

Ampco Pumps Company

4424 West Mitchell Street
 Milwaukee, Wisconsin 53214
 PHONE (414) 643-1852
 FAX (414) 643-4452

Ampco Centrifugal Pumps

DATA SHEET

MODEL ZC2/ZCH2 2X2

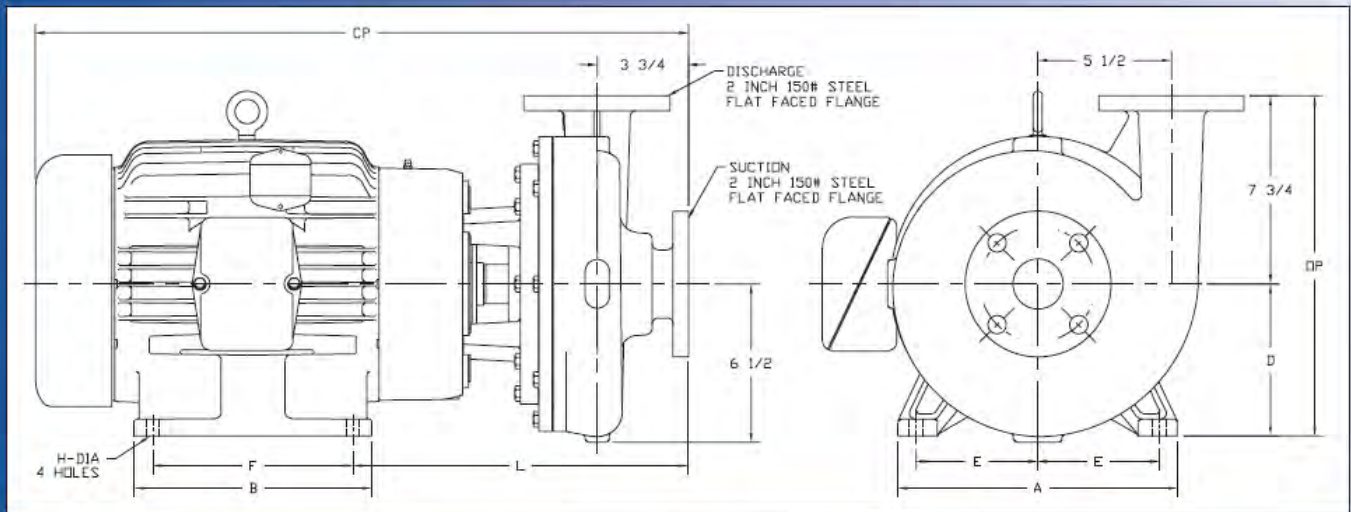

TEFC MOTOR			DIMENSIONS IN INCHES (For Reference Only)									APPROX. WEIGHT (LBS)
HP	RPM	FRAME	A (typ)	B (typ)	D	E	F	H	L	CP	OP	
1-1/2	1750	145JM	6-1/2	6	3-1/2	2-3/4	5	11/32	10-15/16	19-1/4	11-1/4	155
2	1750	145JM	6-1/2	6	3-1/2	2-3/4	5	11/32	10-15/16	19-1/4	11-1/4	162
3	1750	182JM	8-5/8	6-1/2	4-1/2	3-3/4	4-1/2	13/32	11-9/16	20-5/8	12-1/4	171
5	1750	184JM	8-5/8	6-1/2	4-1/2	3-3/4	4-1/2	13/32	11-9/16	22-1/8	12-1/4	195
7-1/2	1750	213JM	9-1/2	8	5-1/4	4-1/4	5-1/2	13/32	12-9/16	23-5/8	13	246
15	3500	254JM	11-1/2	9-3/4	6-1/4	5	8-1/4	17/32	14-1/32	26-7/8	14	405
20	3500	256JM	11-1/2	11-1/2	6-1/4	5	10	17/32	14-1/32	28-5/8	14	443
25	3500	284JM	12-3/4	12-3/4	7	5-1/2	9-1/2	17/32	14-1/32	32-1/4	14-3/4	591
30	3500	286JM	12-3/4	12-3/4	7	5-1/2	11	17/32	14-1/32	32-7/8	14-3/4	652
40	3500	324JM	14-1/2	14	8	6-1/4	10-1/2	21/32	14-17/32	34-1/8	15-3/4	747

MATERIAL SPECIFICATIONS

PART NAME	NICKEL ALUMINUM BRONZE	STAINLESS STEEL	DUPLEX 2205
Casing, Cover, & Impeller	AMPCO® 483	316 Stainless	Duplex 2205
Wear Rings	AMPCO® 18	316 Stainless	Duplex 2205
Motor Shaft	Steel	Steel	Steel
Shaft Sleeve	AMPCO® 18	316 Stainless	Duplex 2205
Adapter	Cast Iron	Cast Iron	Cast Iron

Ampco Centrifugal Pumps

MODEL ZC2/ZCH2 2X2

Curves show approximate characteristics based on clear 68° water. Rated point is guaranteed.

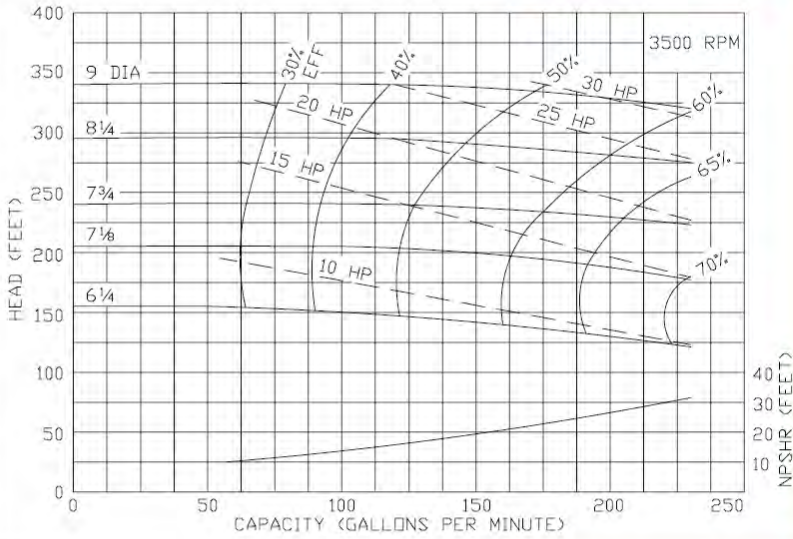

Heavy-duty Z Series pumps have maximum wall thickness and 150 lb. flat faced flanged connections.

Seal options include Type 21, Type 1 and Type 9 with choice of sealing materials.

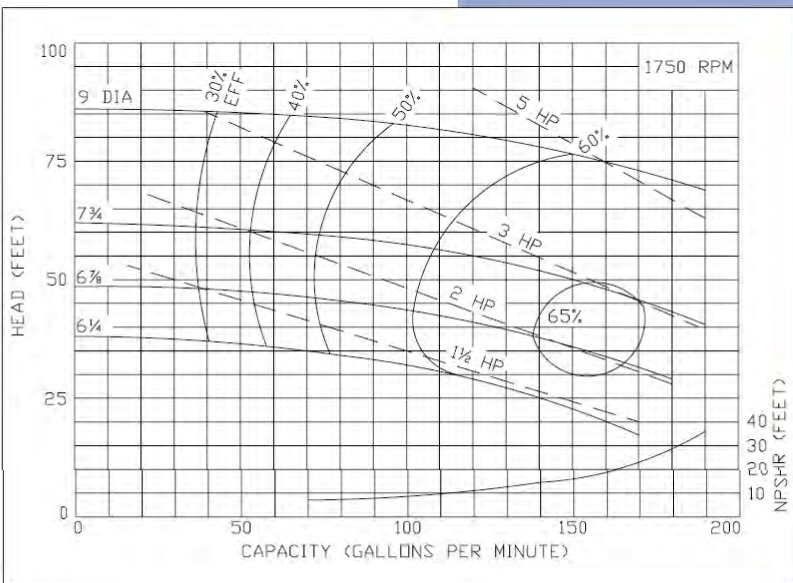
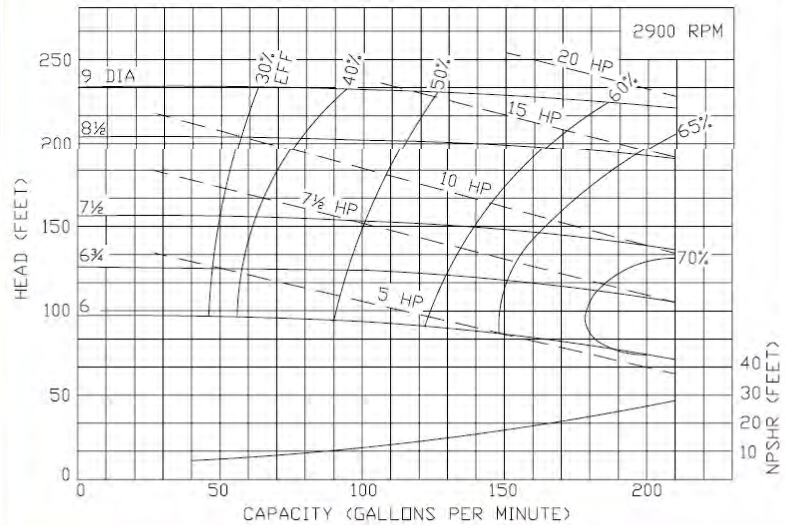

Ampco Pumps Company

4424 West Mitchell Street
 Milwaukee, Wisconsin 53214
 PHONE (414) 643-1852
 FAX (414) 643-4452

Ampco Centrifugal Pumps

DATA SHEET

MODEL ZC2 2 1/2 X 2

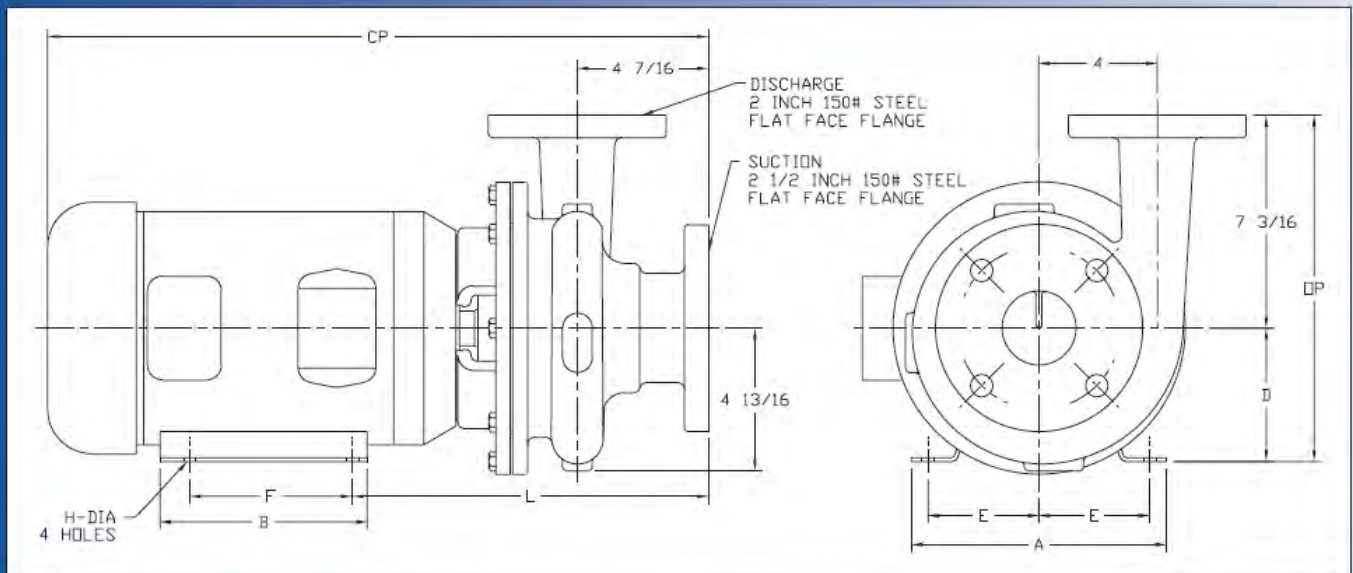

TEFC MOTOR			DIMENSIONS IN INCHES (For Reference Only)									APPROX. WEIGHT (LBS)
HP	RPM	FRAME	A (max)	B (max)	D	E	F	H	L	CP	OP	
1	1750	143JM	6-1/2	6	3-1/2	2-3/4	4	11/32	11-1/2	19-3/4	10-11/16	118
1-1/2	1750	145JM	6-1/2	6	3-1/2	2-3/4	5	11/32	11-1/2	19-3/4	10-11/16	122
2	1750	145JM	6-1/2	6	3-1/2	2-3/4	5	11/32	11-1/2	19-3/4	10-11/16	128
3	1750	182JM	8-5/8	6-1/2	4-1/2	3-3/4	4-1/2	13/32	12-1/8	21-1/8	11-11/16	154
5	3500	184JM	8-5/8	6-1/2	4-1/2	3-3/4	5-1/2	13/32	12-1/8	22-1/2	10-11/16	167
7-1/2	3500	213JM	9-5/8	8-1/8	5-1/4	4-1/4	5-1/2	13/32	13-1/8	25-3/8	12-7/16	235
10	3500	215JM	9-5/8	8-1/8	5-1/4	4-1/4	7	13/32	13-1/8	25-3/8	12-7/16	253
15	3500	215JM	9-1/2	8	5-1/4	4-1/4	7	13/32	13-1/8	25-1/4	12-7/16	277

MATERIAL SPECIFICATIONS

PART NAME	NICKEL ALUMINUM BRONZE	STAINLESS STEEL	DUPLEX 2205
Casing, Cover, & Impeller	AMPCO® 483	316 Stainless	Duplex 2205
Wear Ring	AMPCO® 18	316 Stainless	Duplex 2205
Motor Shaft	Steel	Steel	Steel
Shaft Sleeve	AMPCO® 18	316 Stainless	Duplex 2205
Adapter	Cast Iron	Cast Iron	Cast Iron

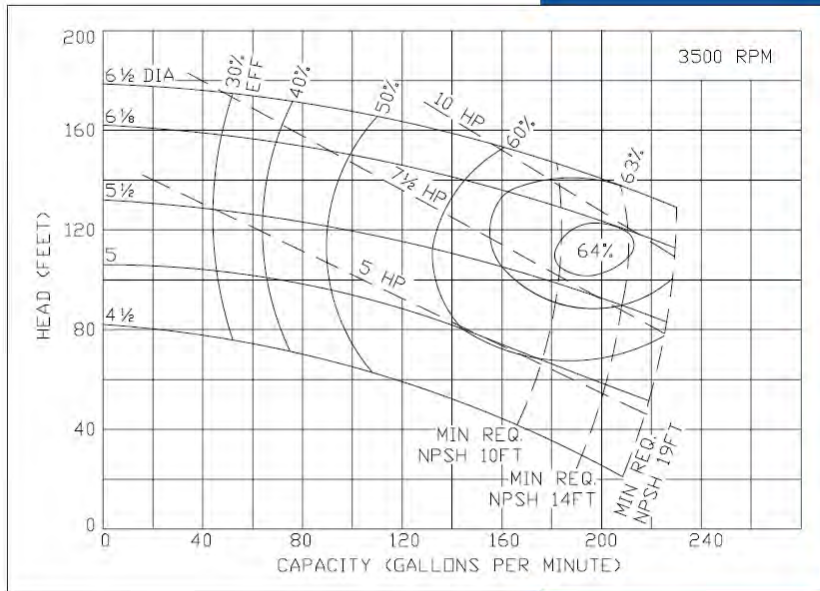

Ampco Centrifugal Pumps

MODEL ZC2 2 1/2 X 2

Curves show approximate characteristics based on clear 68° water. Rated point is guaranteed.

Heavy-duty Z Series pumps have maximum wall thickness and 150 lb. flat faced flanged connections.

Seal options include Type 21, Type 1 and Type 9 with choice of sealing materials.

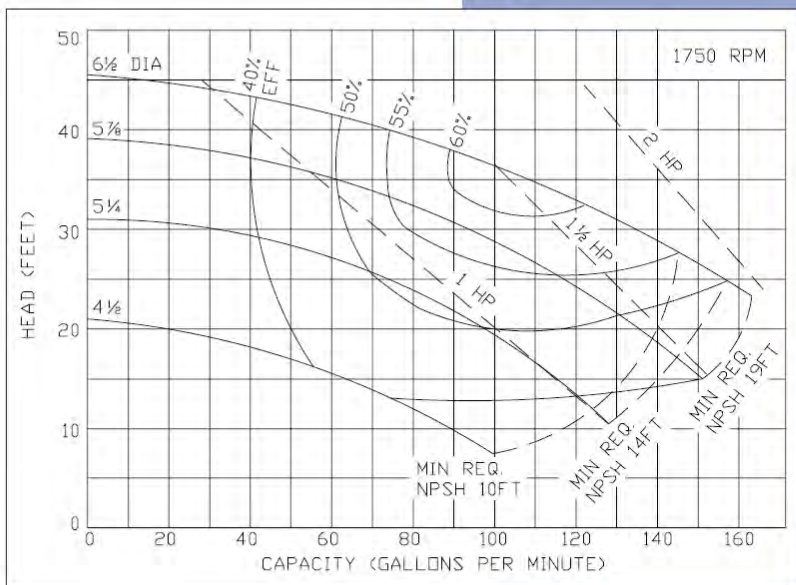
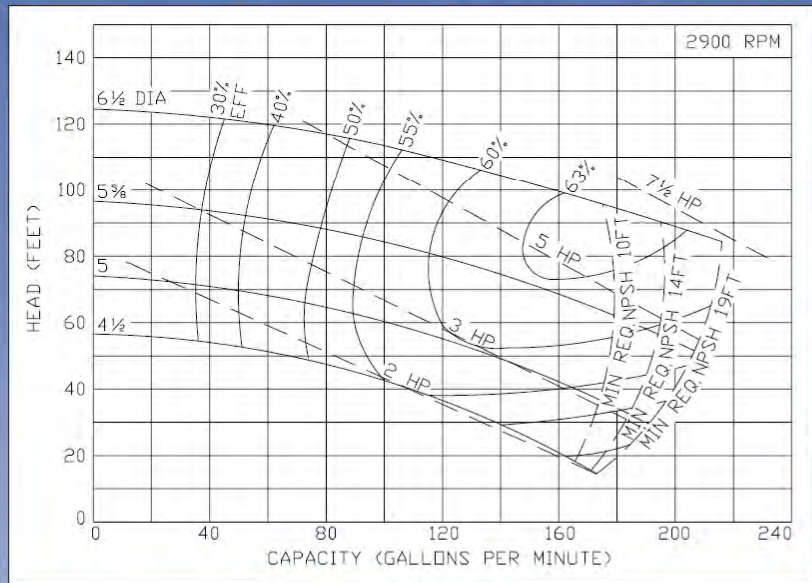

Ampco Pumps Company

4424 West Mitchell Street
 Milwaukee, Wisconsin 53214
 PHONE (414) 643-1852
 FAX (414) 643-4452

Ampco Centrifugal Pumps

DATA SHEET

MODEL ZC2/ZCH2 3X2

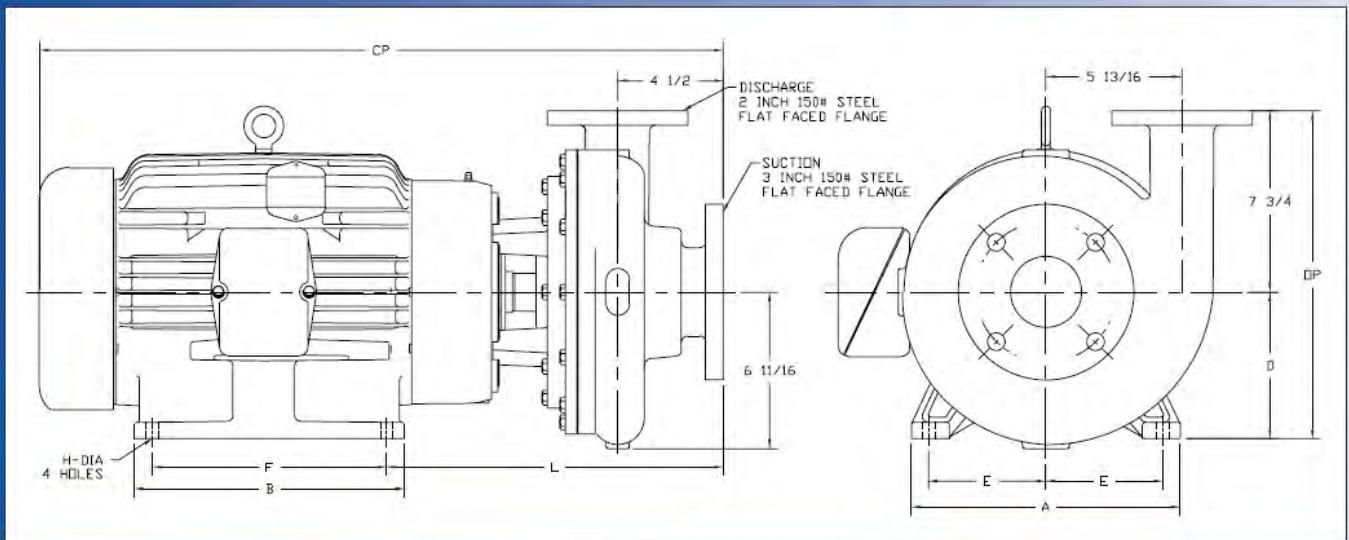

TEFC MOTOR			DIMENSIONS IN INCHES (For Reference Only)										APPROX. WEIGHT (LBS)
HP	RPM	FRAME	A (typ)	B (typ)	D	E	F	H	L	CP	OP		
3	1750	182JM	8-5/8	6-1/2	4-1/2	3-3/4	4-1/2	13/32	12-1/8	21-1/4	12-1/4	179	
5	1750	184JM	8-5/8	6-1/2	4-1/2	3-3/4	5-1/2	13/32	12-1/8	22-3/4	12-1/4	203	
7-1/2	1750	213JM	9-1/2	8	5-1/4	4-1/2	5-1/2	13/32	13-1/8	24-1/4	13	254	
10	1750	215JM	9-1/2	8	5-1/4	4-1/4	7	13/32	13-1/8	25-3/8	13	266	
20	3500	256JM	11-1/2	11-1/2	6-1/4	5	10	17/32	14-3/8	29-1/4	14	433	
25	3500	284JM	12-3/4	12-3/4	7	5-1/2	9-1/2	17/32	14-3/8	32-7/8	14-3/4	599	
30	3500	286JM	12-3/4	12-3/4	7	5-1/2	11	17/32	14-3/8	33-7/16	14-3/4	660	
40	3500	324JM	14	12	8	6-1/4	10-1/2	21/32	14-7/8	34-3/4	15-3/4	755	
50	3500	326JM	14-1/2	14	8	6-1/4	12	21/32	14-7/8	34-3/4	15-3/4	773	

MATERIAL SPECIFICATIONS

PART NAME	NICKEL ALUMINUM BRONZE	STAINLESS STEEL	DUPLEX 2205
Casing, Cover, & Impeller	AMPCO® 483	316 Stainless	Duplex 2205
Wear Rings	AMPCO® 18	316 Stainless	Duplex 2205
Motor Shaft	Steel	Steel	Steel
Shaft Sleeve	AMPCO® 18	316 Stainless	Duplex 2205
Adapter	Cast Iron	Cast Iron	Cast Iron

Ampco Centrifugal Pumps

MODEL ZC2/ZCH2 3X2

Curves show approximate characteristics based on clear 68° water. Rated point is guaranteed.

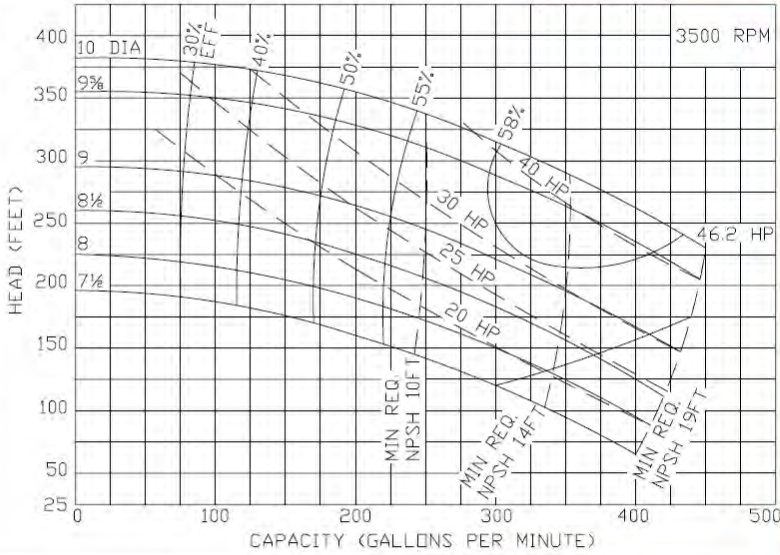

Heavy-duty Z Series pumps have maximum wall thickness and 150 lb. flat faced flanged connections.

Seal options include Type 21, Type 1 and Type 9 with choice of sealing materials.

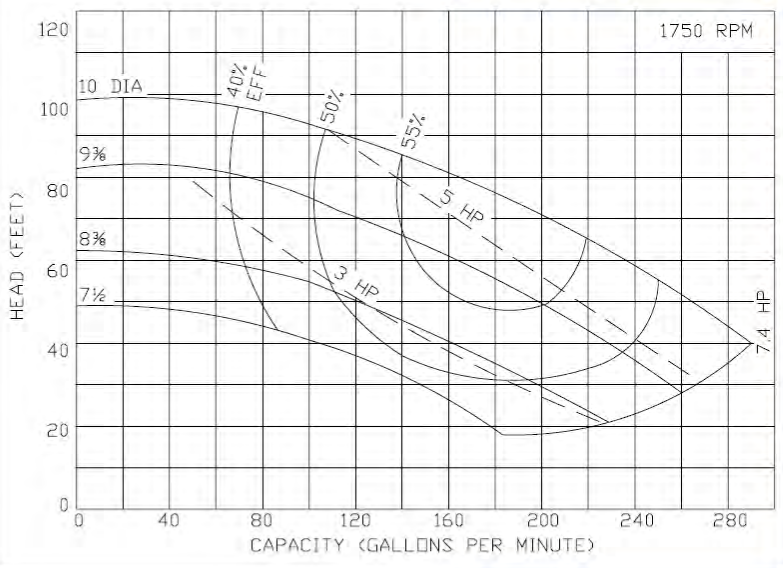
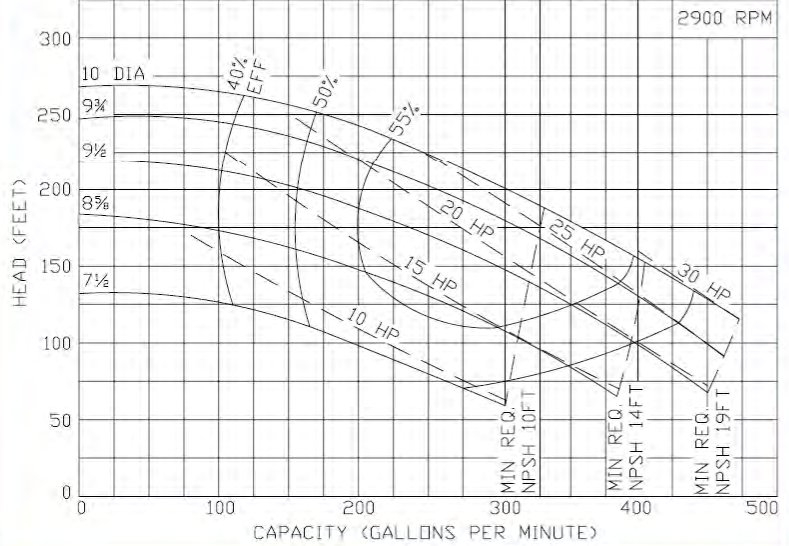

Ampco Pumps Company

4424 West Mitchell Street
 Milwaukee, Wisconsin 53214
 PHONE (414) 643-1852
 FAX (414) 643-4452

Ampco Centrifugal Pumps

DATA SHEET

MODEL ZC2/ZCH2 3X2¹/₂

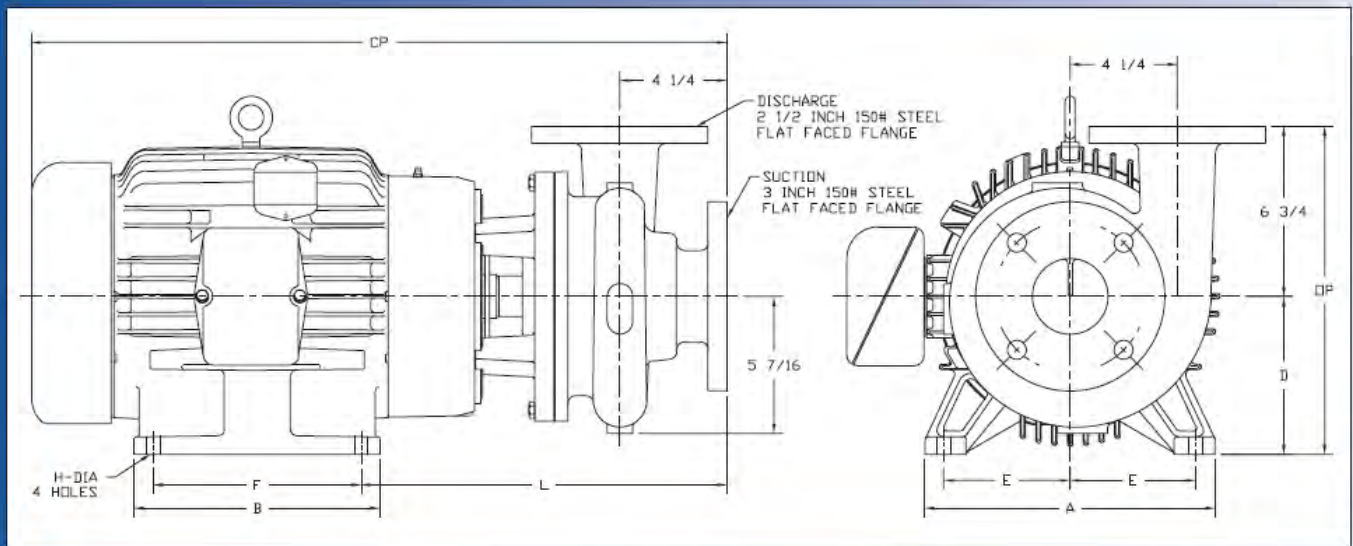

	TEFC MOTOR			DIMENSIONS IN INCHES (For Reference Only)									APPROX. WEIGHT (LBS)
	HP	RPM	FRAME	A (max)	B (max)	D	E	F	H	L	CP	OP	
ZC2	1	1750	143JM	6-1/2	6	3-1/2	2-3/4	4	11/32	11-5/8	19-15/16	10-1/4	129
ZC2	1-1/2	1750	145JM	6-1/2	6	3-1/2	2-3/4	5	11/32	11-5/8	19-15/16	10-1/4	133
ZC2	2	1750	145JM	6-1/2	6	3-1/2	2-3/4	5	11/32	11-5/8	19-15/16	10-1/4	139
ZC2	3	1750	182JM	8-5/8	6-1/2	4-1/2	3-3/4	4-1/2	13/32	12-1/4	21-5/16	11-1/4	165
ZC2	5	3500	184JM	8-5/8	6-1/2	4-1/2	3-3/4	5-1/2	13/32	12-1/4	22-11/16	11-1/4	178
ZC2	7-1/2	3500	213JM	9-5/8	8-1/8	5-1/4	4-1/4	5-1/2	13/32	13-1/4	25-9/16	12	246
ZC2	10	3500	215JM	9-5/8	8-1/8	5-1/4	4-1/4	7	13/32	13-1/4	25-9/16	12	264
ZCH2	15	3500	254JM	11-1/2	9-3/4	6-1/4	5	8-1/4	17/32	14-1/2	27-9/16	13	361
ZCH2	20	3500	256JM	11-1/2	11-1/2	6-1/4	5	10	17/32	14-1/2	29-3/8	13	399
ZCH2	25	3500	284JM	12-3/4	12-3/4	7	5-1/2	9-1/2	9/16	14-1/2	32-15/16	13-3/4	529

MATERIAL SPECIFICATIONS

PART NAME	NICKEL ALUMINUM BRONZE	STAINLESS STEEL	DUPLEX 2205
Casing, Cover, & Impeller	AMPCO® 483	316 Stainless	Duplex 2205
Wear Ring	AMPCO® 18	316 Stainless	Duplex 2205
Motor Shaft	Steel	Steel	Steel
Shaft Sleeve	AMPCO® 18	316 Stainless	Duplex 2205
Adapter	Cast Iron	Cast Iron	Cast Iron

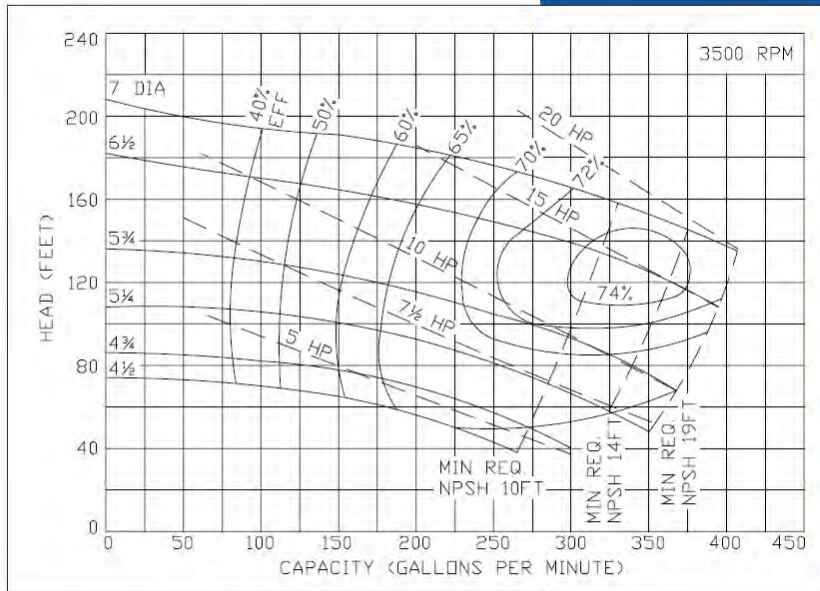

Ampco Centrifugal Pumps

MODEL ZC2/ZCH2 3X2¹/₂

Curves show approximate characteristics based on clear 68° water. Rated point is guaranteed.

Heavy-duty Z Series pumps have maximum wall thickness and 150 lb. flat faced flanged connections.

Seal options include Type 21, Type 1 and Type 9 with choice of sealing materials.

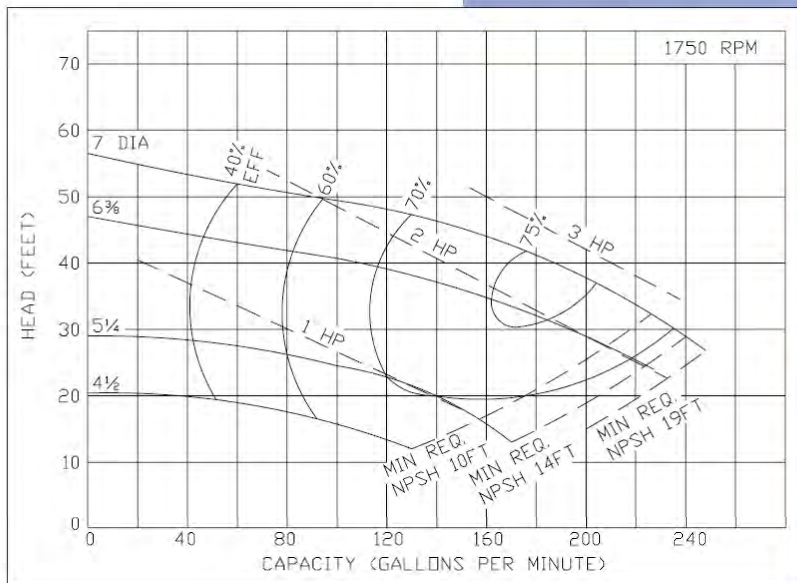
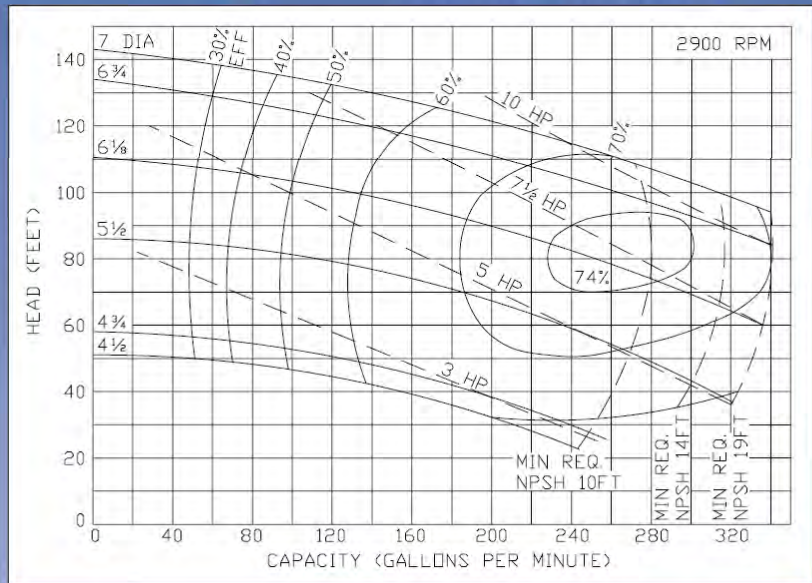

Ampco Pumps Company

4424 West Mitchell Street
 Milwaukee, Wisconsin 53214
 PHONE (414) 643-1852
 FAX (414) 643-4452

Ampco Centrifugal Pumps

DATA SHEET

MODEL ZC2/ZCH2 4X3

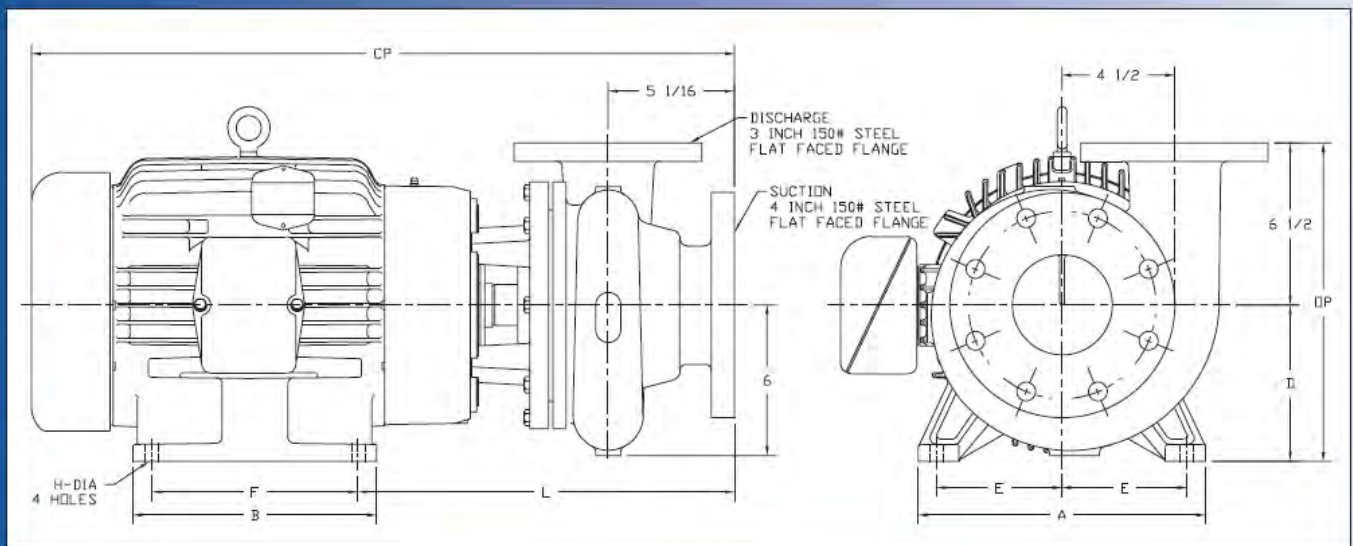

	TEFC MOTOR			DIMENSIONS IN INCHES (For Reference Only)									APPROX. WEIGHT (LBS)
	HP	RPM	FRAME	A (max)	B (max)	D	E	F	H	L	CP	OP	
ZC2	1-1/2	1750	145JM	6-1/2	6	3-1/2	2-3/4	5	11/32	12-3/16	20-1/2	10	152
ZC2	2	1750	145JM	6-1/2	6	3-1/2	2-3/4	5	11/32	12-3/16	20-1/2	10	158
ZC2	3	1750	182JM	8-5/8	6-1/2	4-1/2	3-3/4	4-1/2	13/32	12-13/16	21-7/8	11	184
ZC2	5	1750	184JM	8-5/8	6-1/2	4-1/2	3-3/4	5-1/2	13/32	12-13/16	23-7/16	11	197
ZC2	10	3500	215JM	9-5/8	8-1/8	5-1/4	4-1/4	7	13/32	13-9/16	26-1/8	11-3/4	283
ZCH2	15	3500	254JM	11-1/2	9-3/4	6-1/4	5	8-1/4	17/32	15-1/16	28-1/8	12-3/4	391
ZCH2	20	3500	256JM	11-1/2	11-1/2	6-1/4	5	10	17/32	15-1/16	29-15/16	12-3/4	429
ZCH2	25	3500	284JM	12-3/4	12-3/4	7	5-1/2	9-1/2	9/16	15-1/16	33-1/2	13-1/2	559
ZCH2	30	3500	286JM	12-3/4	12-3/4	7	5-1/2	11	9/16	15-1/16	34-1/8	13-1/2	688

MATERIAL SPECIFICATIONS

PART NAME	NICKEL ALUMINUM BRONZE	STAINLESS STEEL	DUPLEX 2205
Casing, Cover, & Impeller	AMPCO® 483	316 Stainless	Duplex 2205
Wear Ring	AMPCO® 18	316 Stainless	Duplex 2205
Motor Shaft	Steel	Steel	Steel
Shaft Sleeve	AMPCO® 18	316 Stainless	Duplex 2205
Adapter	Cast Iron	Cast Iron	Cast Iron

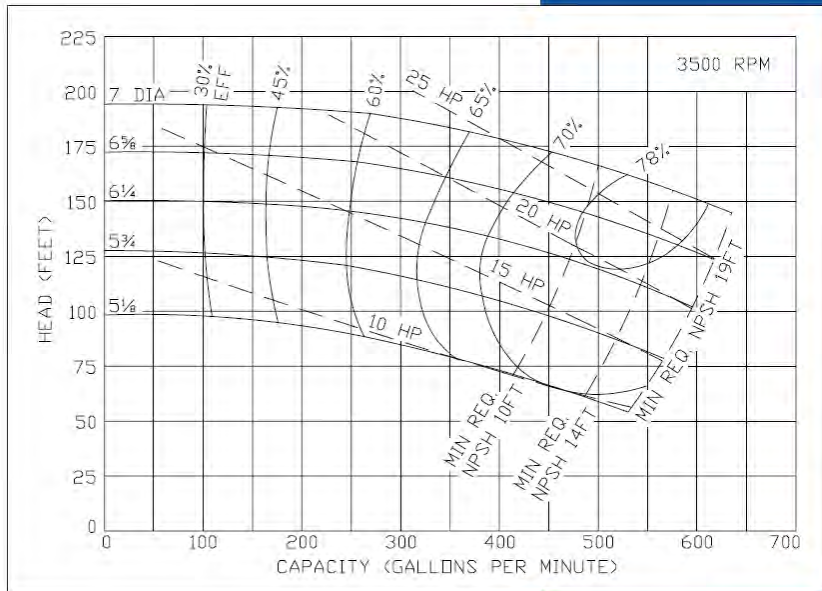

Ampco Centrifugal Pumps

MODEL ZC2/ZCH2 4X3

Curves show approximate characteristics based on clear 68° water. Rated point is guaranteed.

Heavy-duty Z Series pumps have maximum wall thickness and 150 lb. flat faced flanged connections.

Seal options include Type 21, Type 1 and Type 9 with choice of sealing materials.

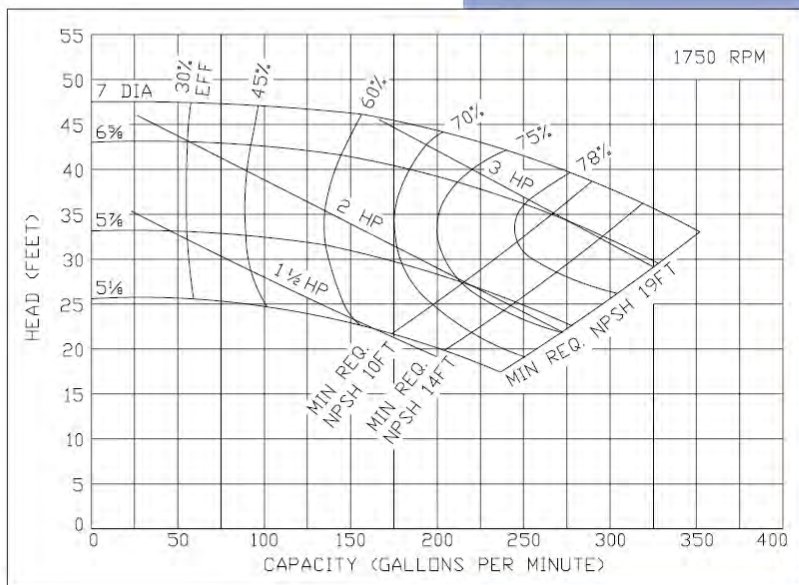
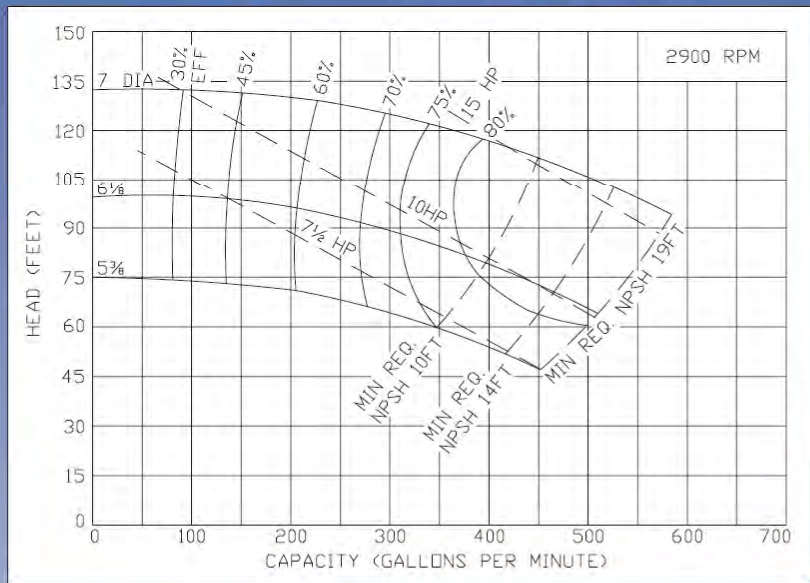

Ampco Pumps Company

4424 West Mitchell Street
 Milwaukee, Wisconsin 53214
 PHONE (414) 643-1852
 FAX (414) 643-4452

Ampco Centrifugal Pumps

DATA SHEET

MODEL ZC2/ZCH2 4X3C

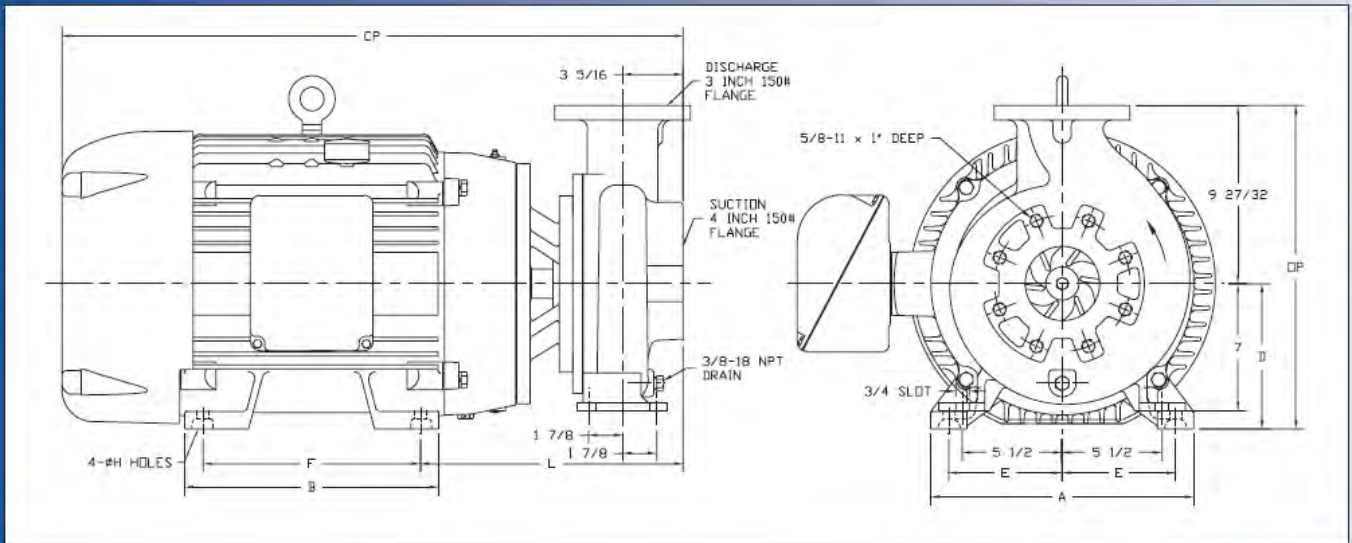

	TEFC MOTOR			DIMENSIONS IN INCHES (For Reference Only)									APPROX. WEIGHT (LBS)
	HP	RPM	FRAME	A (max)	B (max)	D	E	F	H	L	CP	OP	
ZC2	3	1750	182JM	8-5/8	6-1/2	4-1/2	3-3/4	4-1/2	13/32	11-15/32	20-17/32	14-11/32	204
ZC2	5	1750	184JM	8-5/8	6-1/2	4-1/2	3-3/4	5-1/2	13/32	11-15/32	22-1/16	14-11/32	228
ZC2	7-1/2	1750	213JM	9-1/2	8	5-1/4	4-1/4	5-1/2	13/32	12-15/32	23-17/32	15-3/32	279
ZC2	10	1750	215JM	9-1/2	8	5-1/4	4-1/4	7	13/32	12-15/32	24-21/32	15-3/32	293
ZC2	15	1750	254JM	11-1/2	9-3/4	6-1/4	5	8-1/4	17/32	13-23/32	26-13/16	16-3/32	456
ZCH2	30	3500	286JM	12-3/4	12-3/4	7	5-1/2	11	9/16	13-31/32	32-25/32	16-27/32	685
ZCH2	40	3500	324JM	14-1/2	14	8	6-1/4	10-1/2	21/32	14-15/32	34-1/4	17-27/32	780
ZCH2	50	3500	326JM	14-1/2	14	8	6-1/4	12	21/32	14-15/32	34-1/4	17-27/32	789

MATERIAL SPECIFICATIONS

PART NAME	NICKEL ALUMINUM BRONZE	STAINLESS STEEL	DUPLEX 2205
Casing, Cover, & Impeller	AMPCO® 483	316 Stainless	Duplex 2205
Wear Ring	AMPCO® 18	316 Stainless	Duplex 2205
Motor Shaft	Steel	Steel	Steel
Shaft Sleeve	AMPCO® 18	316 Stainless	Duplex 2205
Adapter	Cast Iron	Cast Iron	Cast Iron

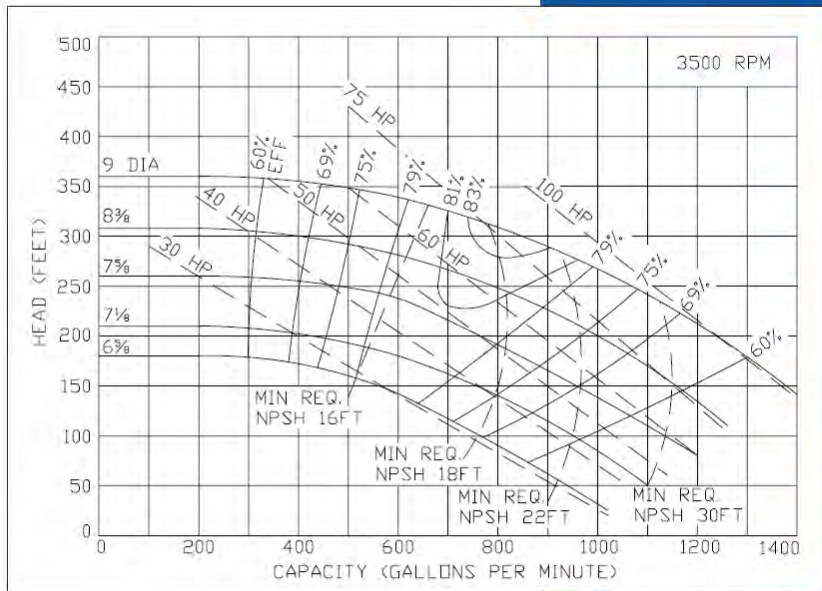

Ampco Centrifugal Pumps

MODEL ZC2/ZCH2 4X3C

Curves show approximate characteristics based on clear 68° water. Rated point is guaranteed.

Heavy-duty Z Series pumps have maximum wall thickness and 150 lb. flat faced flanged connections. Seal options include Type 21, Type 1 and Type 9 with choice of sealing materials.

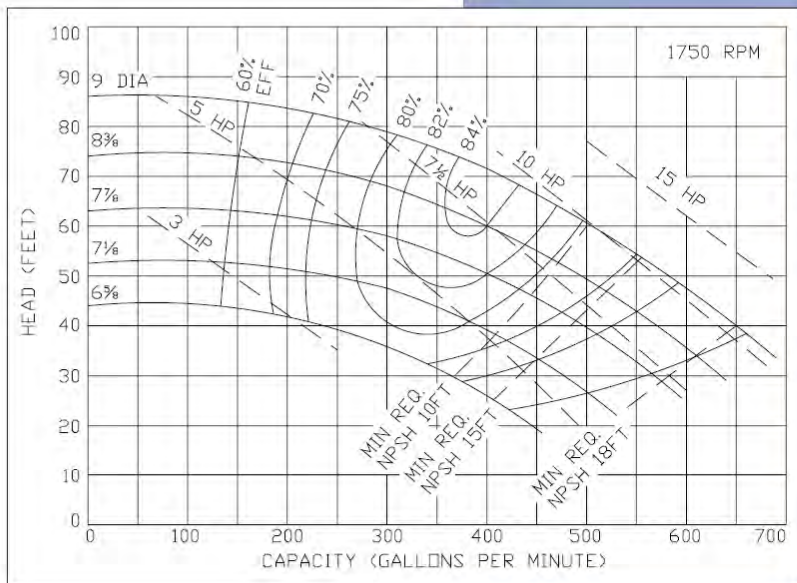
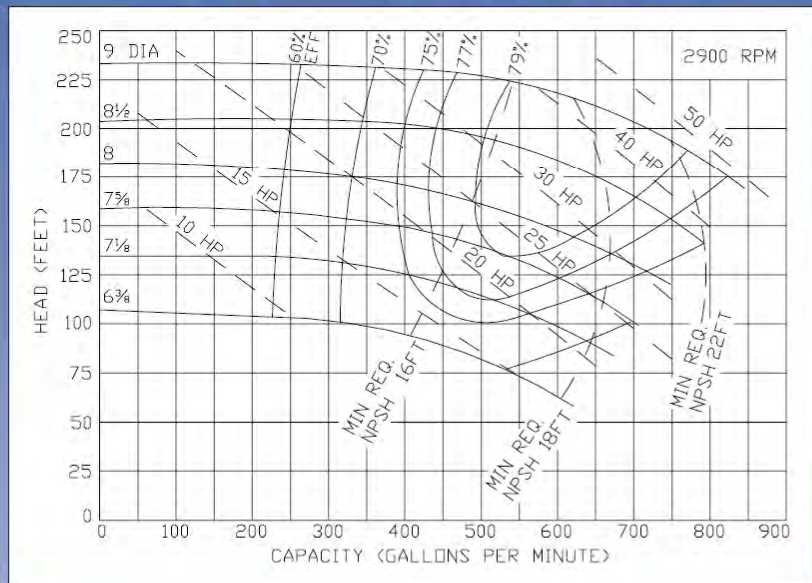

Ampco Pumps Company

4424 West Mitchell Street
Milwaukee, Wisconsin 53214
PHONE (414) 643-1852
FAX (414) 643-4452

Ampco Centrifugal Pumps

DATA SHEET

MODEL ZC2/ZCH2 4X3L

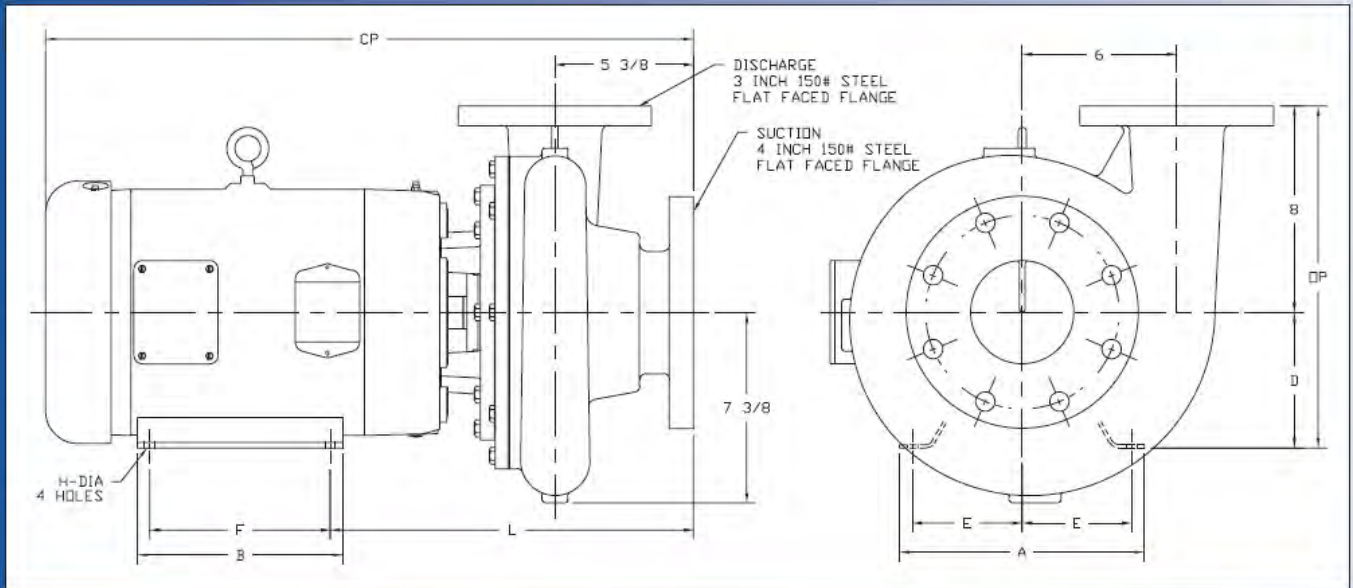

TEFC MOTOR			DIMENSIONS IN INCHES (For Reference Only)									APPROX. WEIGHT (LBS)
HP	RPM	FRAME	A (typ)	B (typ)	D	E	F	H	L	CP	OP	
7-1/2	1750	213JM	9-1/2	8	5-1/4	4-1/4	5-1/2	13/32	14-1/8	25-1/8	13-1/4	296
10	1750	215JM	9-1/2	8	5-1/4	4-1/4	7	13/32	14-1/8	26-5/16	13-1/4	314
15	1750	254JM	11-1/2	9-3/4	6-1/4	5	8-1/4	17/32	15-3/8	28-7/16	14-1/4	400
20	1750	256JM	11-1/2	11-1/2	6-1/4	5	10	17/32	15-3/8	30-1/2	14-1/4	525

MATERIAL SPECIFICATIONS

PART NAME	NICKEL ALUMINUM BRONZE	STAINLESS STEEL	DUPLEX 2205
Casing, Cover, & Impeller	AMPCO® 483	316 Stainless	Duplex 2205
Wear Rings	AMPCO® 18	316 Stainless	Duplex 2205
Motor Shaft	Steel	Steel	Steel
Shaft Sleeve	AMPCO® 18	316 Stainless	Duplex 2205
Adapter	Cast Iron	Cast Iron	Cast Iron

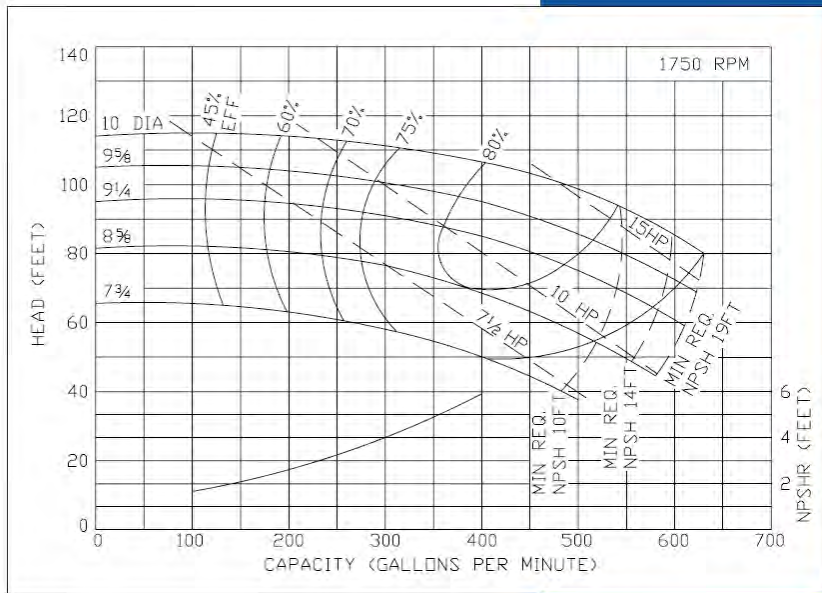

Ampco Centrifugal Pumps

MODEL ZC2/ZCH2 4X3L

Curves show approximate characteristics based on clear 68° water. Rated point is guaranteed.

Heavy-duty Z Series pumps have maximum wall thickness and 150 lb. flat faced flanged connections.

Seal options include Type 21, Type 1 and Type 9 with choice of sealing materials.

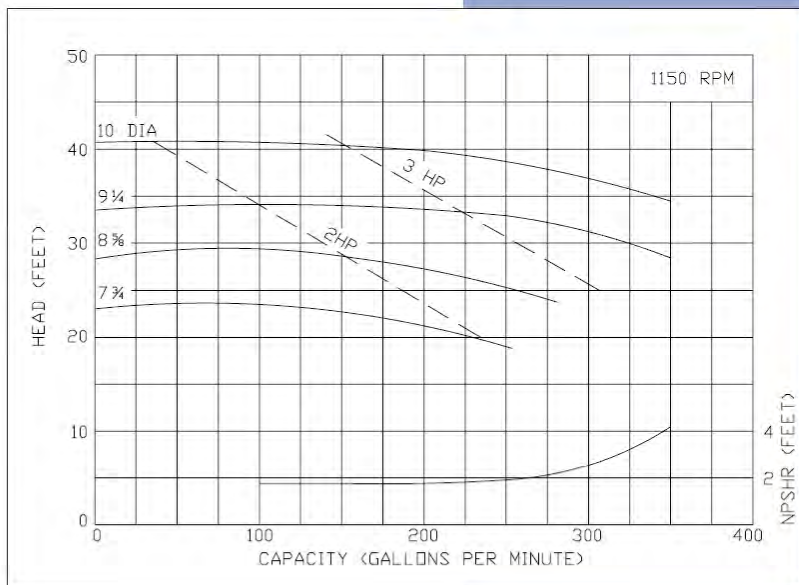
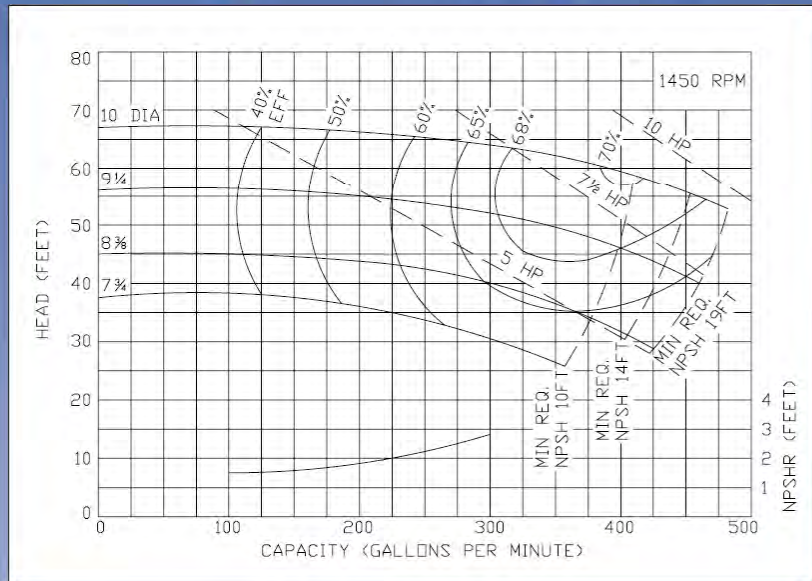

Ampco Pumps Company

4424 West Mitchell Street
 Milwaukee, Wisconsin 53214
 PHONE (414) 643-1852
 FAX (414) 643-4452

Ampco Centrifugal Pumps

DATA SHEET

MODEL ZCH2 5 x 4P

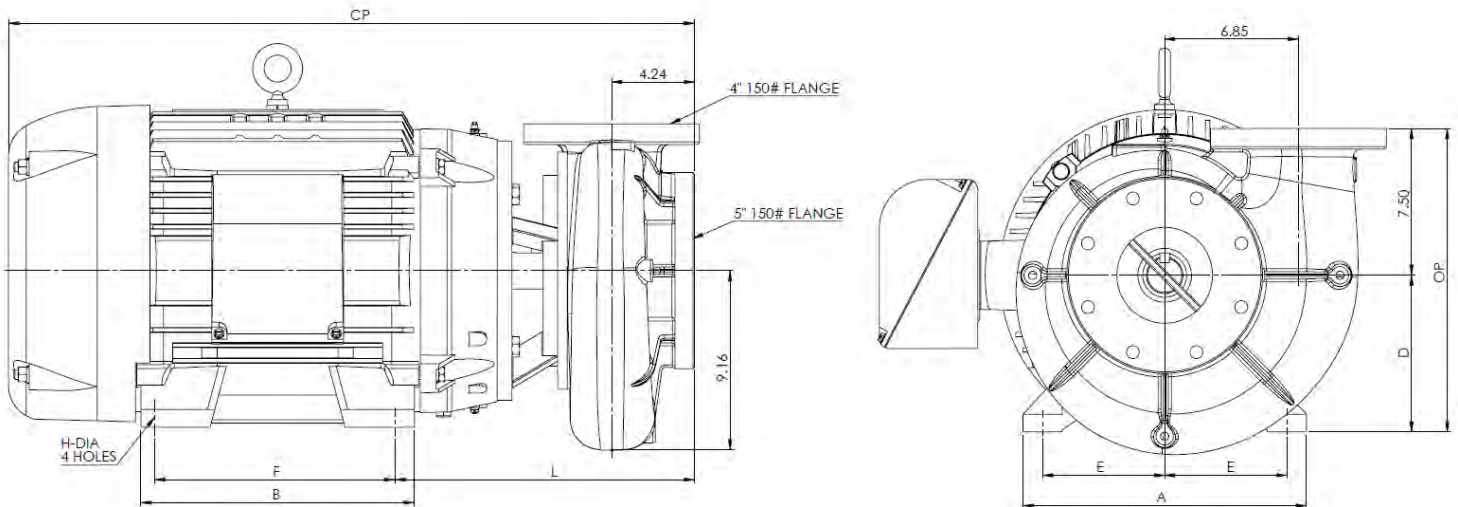
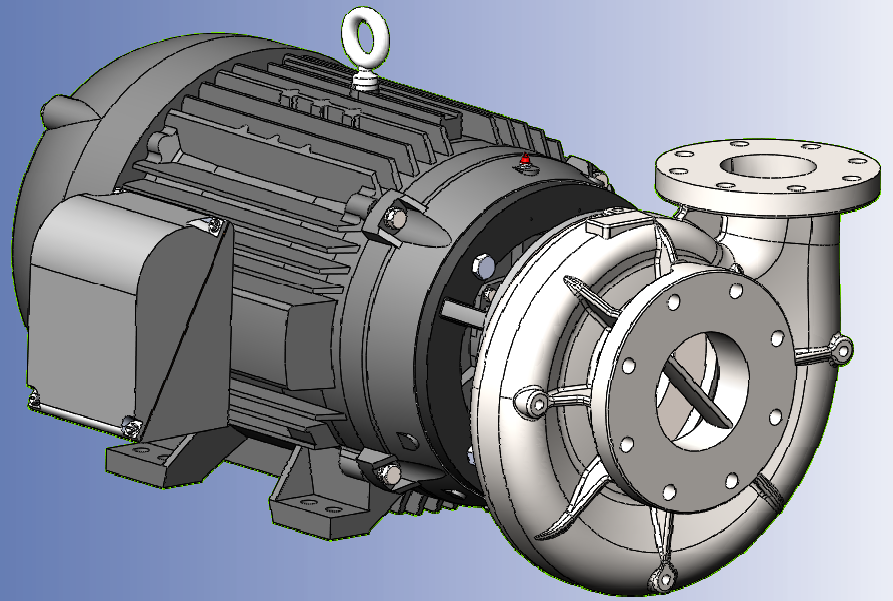

NEMA JM MOTOR			DIMENSIONS IN INCHES (For Reference Only)									APPROX. WEIGHT (lbs)
HP	RPM	FRAME	A (max)	B (max)	D	E	F	H	L	CP	OP	
10	1750	215JM	9.50	8.00	5.25	4.25	7.00	13/32	13.36	25.50	12.75	351
15	1750	254JM	11.50	9.75	6.25	5.00	8.25	17/32	14.86	27.68	13.75	452
20	1750	256JM	11.50	11.50	6.25	5.00	10.00	17/32	14.86	34.68	13.75	460
25	1750	284JM	12.75	12.84	7.00	5.50	11.00	17/32	14.86	31.56	14.50	525
30	1750/3500	286JM	12.75	12.84	7.00	5.50	11.00	17/32	14.86	31.56	14.50	590
40	3500	324JM	14.50	14.00	8.00	6.25	12.00	21/32	15.35	35.23	15.50	661
50	3500	326JM	14.50	14.00	8.00	6.25	12.00	21/32	15.35	35.23	15.50	685
60	3500	326JM	14.50	14.00	8.00	6.25	12.00	21/32	15.35	Contact Ampco	15.50	Contact Ampco
75	3500	326JM	14.50	14.00	8.00	6.25	12.00	21/32	15.35	Contact Ampco	15.50	Contact Ampco
100	3500	405TCZ	Contact Ampco	Contact Ampco	10.00	8.00	Contact Ampco	13/16	Contact Ampco	Contact Ampco	17.50	Contact Ampco

MATERIAL SPECIFICATIONS

PART NAME	NICKEL ALUMINUM BRONZE	STAINLESS STEEL
Casing, Cover & Impeller	AMPCO® 483	316 Stainless
Wear Ring	AMPCO® 18	316 Stainless
Motor Shaft	Steel	Steel
Shaft Sleeve	AMPCO® 18	316 Stainless
Adapter	Cast Iron	Cast Iron

* Also available in Duplex 2205

Ampco Centrifugal Pumps

DATA SHEET

MODEL ZCH2 6X6

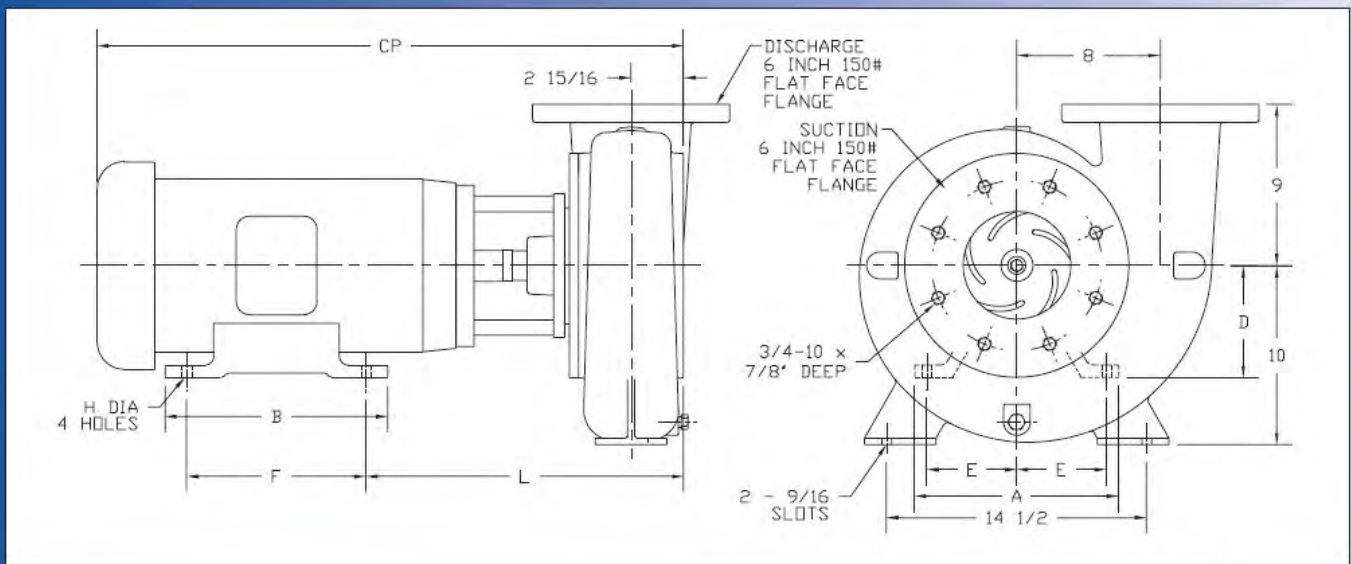

TEFC MOTOR			DIMENSIONS IN INCHES (For Reference Only)								APPROX. WEIGHT (LBS)
HP	RPM	FRAME	A (typ)	B (typ)	D	E	F	H	L	CP	
10	1750	215JP	9-1/2	8	5-1/4	4-1/4	7	13/32	17	28-1/16	439
15	1750	254JP	11-1/2	9-3/4	6-1/4	5	8-1/4	17/32	17-1/4	30-5/16	537
20	1750	256JP	11-1/2	11-1/2	6-1/4	5	10	17/32	17-1/4	32-3/16	570
25	1750	284JP	12-3/4	12-3/4	7	5-1/2	9-1/2	17/32	17-1/4	35-11/16	764
30	1750	286JP	12-3/4	12-3/4	7	5-1/2	11	17/32	17-1/4	36-5/16	774

MATERIAL SPECIFICATIONS

PART NAME	NICKEL ALUMINUM BRONZE	STAINLESS STEEL	DUPLEX 2205
Casing, Cover, & Impeller	AMPCO® 483	316 Stainless	Duplex 2205
Wear Ring	AMPCO® 18	316 Stainless	Duplex 2205
Motor Shaft	Steel	Steel	Steel
Shaft Sleeve	AMPCO® 18	316 Stainless	Duplex 2205
Adapter	Cast Iron	Cast Iron	Cast Iron

Ampco Centrifugal Pumps

MODEL ZCH2 6X6

Curves show approximate characteristics based on clear 68° water. Rated point is guaranteed.

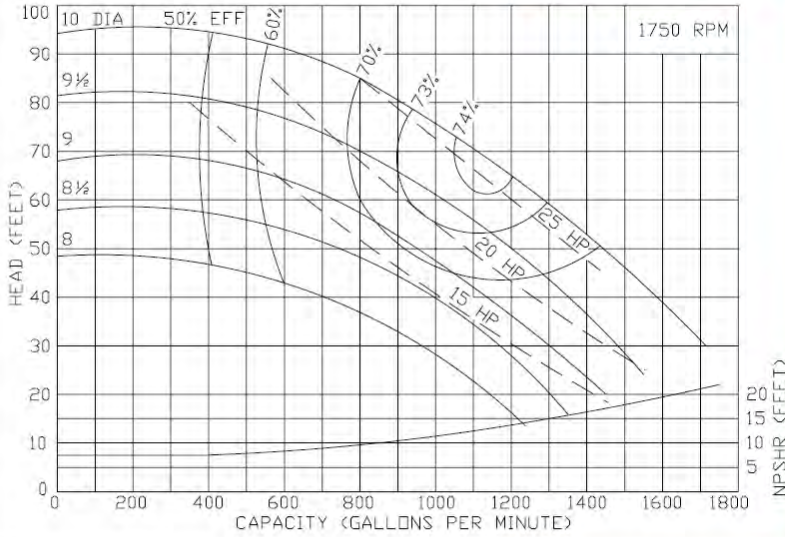

Heavy-duty Z Series pumps have maximum wall thickness and 150 lb. flat faced flanged connections.

Seal options include Type 21, Type 1 and Type 9 with choice of sealing materials.

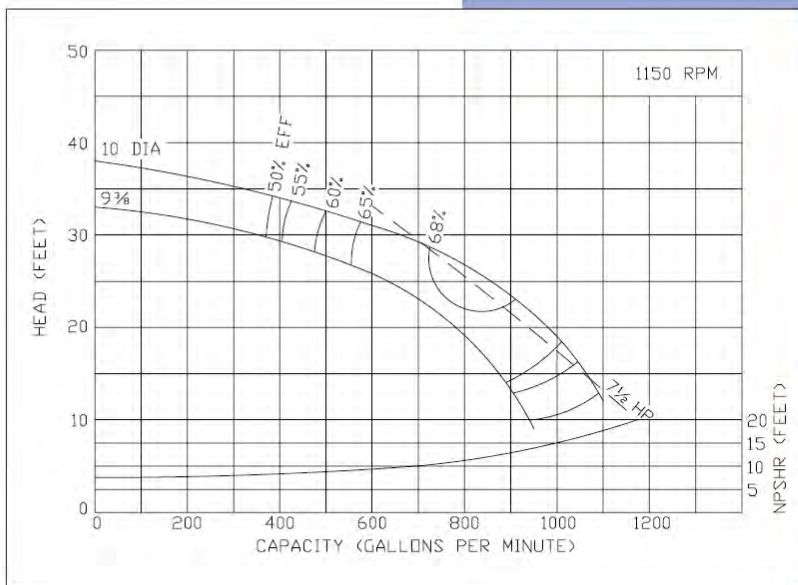
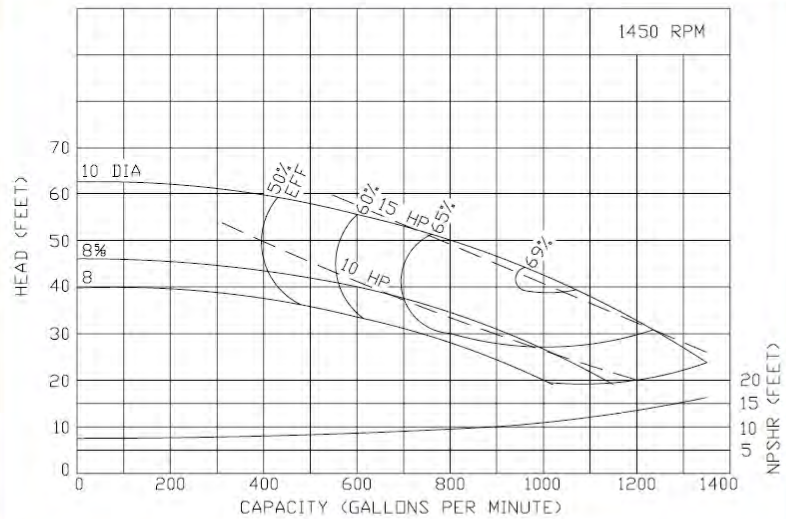

Ampco Pumps Company

4424 West Mitchell Street
 Milwaukee, Wisconsin 53214
 PHONE (414) 643-1852
 FAX (414) 643-4452

Ampco Centrifugal Pumps

DATA SHEET

MODEL ZCH2 8 x 6

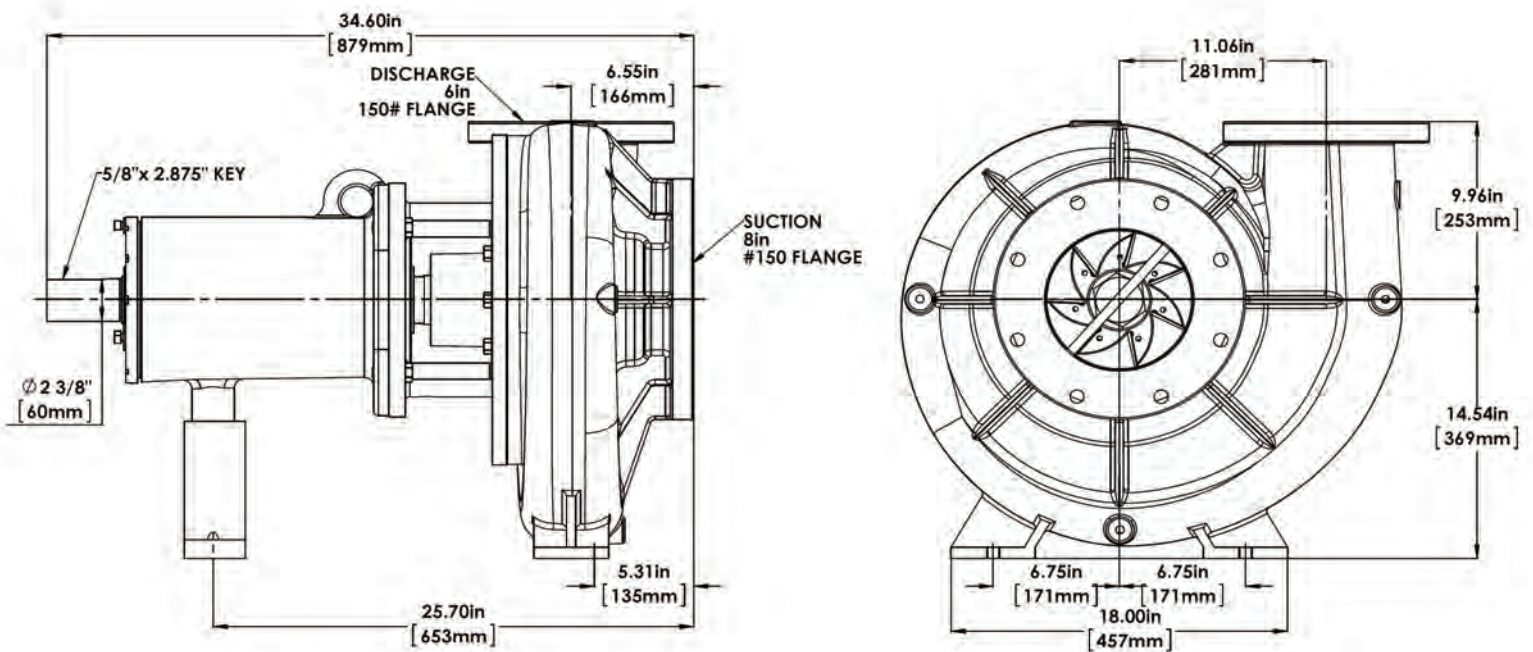
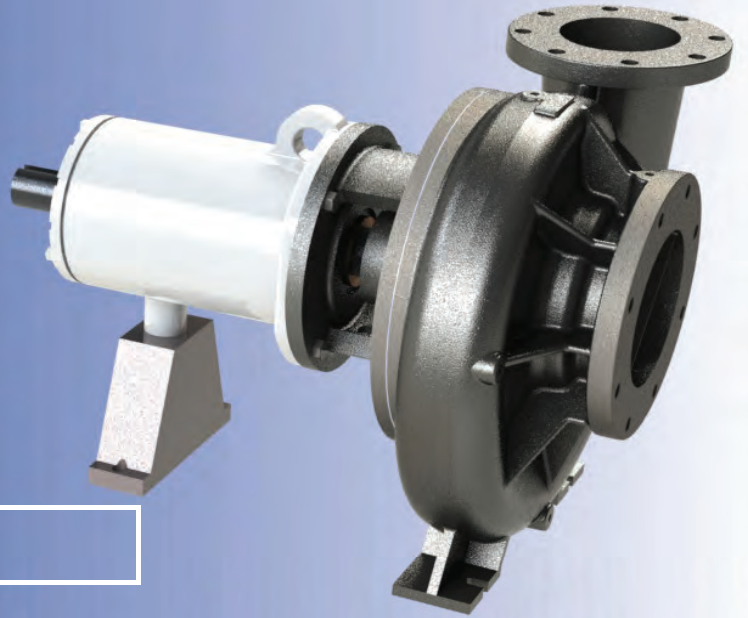

MATERIAL SPECIFICATIONS

PART NAME	Material
Casing, Cover & Impeller	Duplex 2205
Stub Shaft	17-4 PH
Adapter	Cast Iron

Ampco Centrifugal Pumps



DATA SHEET

MODEL ZCH2 8 X 6M

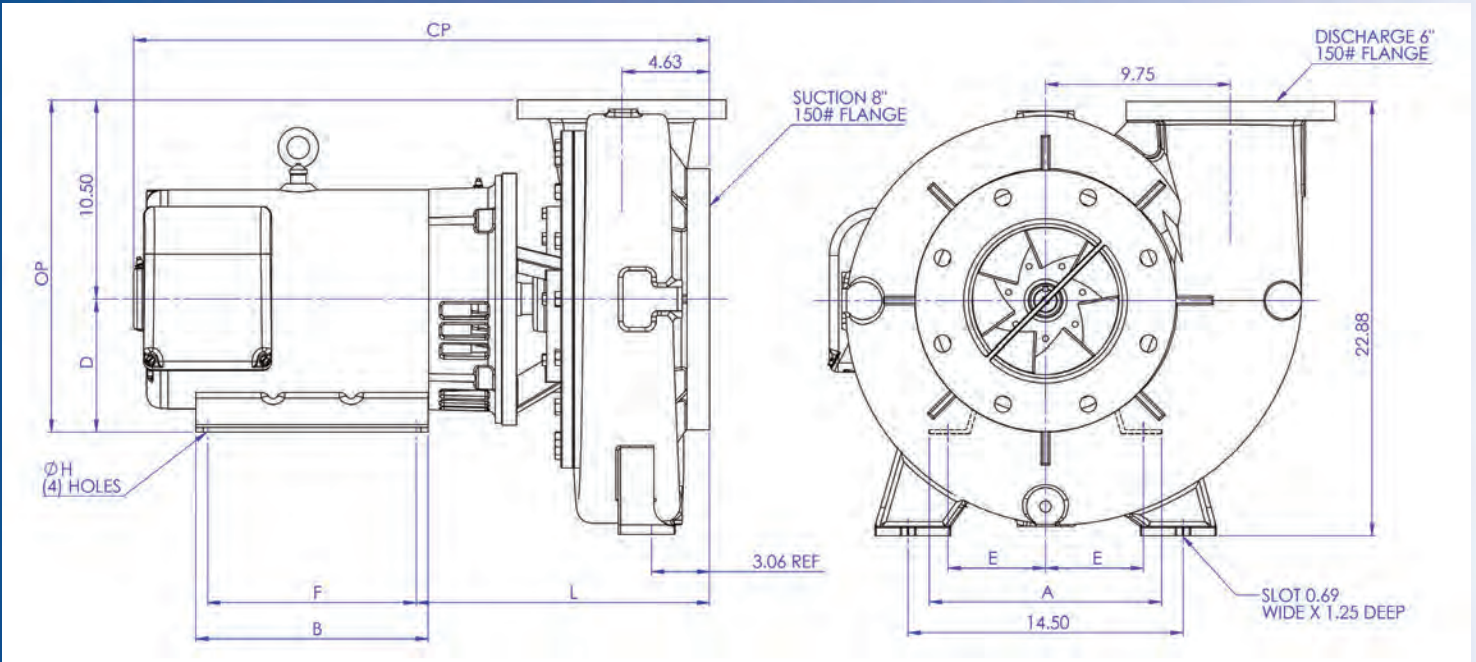

NEMA JM MOTOR			DIMENSIONS IN INCHES (For Reference Only)									APPROX WEIGHT (lbs)
HP	RPM	FRAME	A (typ)	B (typ)	D	E	F	H	L	CP	OP	
20	1750	256JM	11-1/2	11-1/2	6-1/4	5	10	0.53	15-11/16	30-1/2	16-3/4	622
25	1750	284JM	12-1/4	12-1/4	7	5-1/2	11	0.57	15-1/2	30-3/8	17-1/2	662
30	1750	286JM	12-1/4	12-1/4	7	5-1/2	11	0.57	15-1/2	31-7/8	17-1/2	682
40	1750	324JM	14-1/2	14	8	6-1/4	12	0.66	16-3/16	36-1/16	18-1/2	872
50	1750	326JM	14-1/4	13-3/4	8	6-1/4	12	0.69	16-3-16	32-7/8	18-1/2	782
60	1750	364JM	17	15	9	7	12-1/4	0.69	17-1/16	38-3/4	19-1/2	Contact Ampco
75	1750	365JM	17	15	9	7	12-1/4	0.69	17-1/16	38-3/4	19-1/2	Contact Ampco
100	1750	405TCZ	19	16	10	8	13-3/4	0.81	17-13/16	42-1/4	20-1/2	Contact Ampco

MATERIAL SPECIFICATIONS

PART NAME	DUPLEX 2205
Casing, Cover, & Impeller	Duplex 2205
Wear Rings	Duplex 2205
Motor Shaft	Steel
Shaft Sleeve	Duplex 2205
Adapter	Cast Iron