



# Ampco ZP3 Series

## Positive Displacement Pumps

---



---

Installation and Maintenance Manual

---

Original Instructions

M-004 REV G 1/2023

## Safety Notices

**IMPORTANT:** Read and understand this manual BEFORE installation, operation, or maintenance of the pump. Improper installation, operation, or maintenance may result in severe injury or death. Equipment damage caused by user neglect will invalidate the pump warranty.

## Definitions

There are safety symbols used throughout this manual identifying safety concerns.

### **DANGER**

Indicates a hazardous situation that, if not avoided, will result in death or serious injury. This applies to the most extreme situations.

### **Warning**

Indicates a hazardous situation that, if not avoided, could result in death or serious injury.

### **Caution**

Indicates a hazardous situation that, if not avoided, could result in minor or moderate injury.

### **Notice**

Indicates information considered important, but not hazard-related (e.g. messages relating to property damage).

NOTE: Indicates useful, extra information about the procedure you are performing.

## Intended Use

This pump is intended for pumping liquids, especially in food and beverage applications. Do not use the pump in any manner that exceeds the specifications that appear in this manual.

### **Warning**

Use of this pump in a capacity outside the instructions in this manual could result in death or serious injury, along with property damage.

## General Safety Instructions

### **Warning**

- Do not remove safety labels; doing so may result in injury to users.
- During installation, operation, and maintenance, keep fingers out of the pump's ports.
- Follow any provided lifting recommendations when lifting heavy pumps or components.
- Shut off and lockout all power and relieve system pressure before servicing to prevent accidental start-up and injury caused by rotating components.
- Before performing maintenance, make sure the pump is secured. As components are removed or added, tipping could occur, resulting in serious injury.

### **Caution**

- Only trained personnel should perform installation, operation, and maintenance.
- After operation, allow the gear case to warm or cool before handling. Temperatures vary depending on product.
- Shut off product supply to the pump and drain the pump before piping disconnection and pump disassembly.
- During maintenance, handle the rotors, piping, and other pump components carefully as edges may be sharp. Wear personal protective equipment according to the requirements established by applicable directives.
- Protect hands when in contact with strong cleaning solutions.

### **Notice**

- Do not rapidly cool or heat the pump.
- Do not run the motor with the pump dry, which causes damage to pump components.
- Do not obstruct the outlet of the pump, which results in system pressure above the pump's specified maximum.
- To avoid damage to metal and seal parts, do not use abrasive cleaning tools and chemicals.
- Do not use sharp tools to pry components during disassembly.

# Table of Contents

---

	Safety Notices .....	2
	Definitions.....	2
	Intended Use .....	2
	General Safety Instructions.....	2
<b>Section 1</b>		
<b>General Information</b>		
	Introduction .....	5
	General Information .....	5
	Pump Receiving.....	5
	Shipping Damage or Loss.....	5
	Label Information.....	6
<b>Section 2</b>		
<b>Pump Information</b>		
	Pump Design .....	7
	Operating Parameters .....	7
<b>Section 3</b>		
<b>Installation</b>		
	Installation .....	9
	Base Arrangement.....	9
	Piping and Connections .....	10
	Check/Isolation/Relief Valves .....	11
	Strainers and Gauges .....	12
	Base Alignment .....	12
	Pump Rotation .....	13
	Seal Flushing .....	14
	Pre-Start-Up Checklist .....	14
	Start-Up Procedure.....	15
	Shutdown Procedure .....	15
	Emergency Shutdown Procedure .....	15
<b>Section 4</b>		
<b>Maintenance</b>		
	Maintenance .....	17
	Pump Lubrication .....	17
	Preventive Maintenance/Inspection.....	18
	Gear and Bearing Inspection.....	19
	Annual Maintenance .....	20
	Cleaning .....	21
	Pump Disassembly .....	21
	Seal Maintenance.....	24
	Single Mechanical Seal.....	24
	Double Mechanical Seal.....	28
	Seal Cutaways.....	29
	<b>Gear Case Maintenance.....</b>	<b>30</b>
	Disassembly .....	30
	Assembly .....	32
	<b>Pump Assembly.....</b>	<b>37</b>
	<b>Pump Clearances.....</b>	<b>41</b>

Table of Contents (continued)

---

	<b>Ampco Pumps Available Options .....</b>	<b>42</b>
	Vented Cover (Pressure Relief).....	42
	Jacketed Cover .....	42
<b>Section 5</b>		
<b>Troubleshooting</b>		
	<b>Troubleshooting .....</b>	<b>43</b>
<b>Section 6</b>		
<b>Appendix</b>		
	<b>PD Pump Remanufacturing Program.....</b>	<b>45</b>
	<b>ATEX Certification Information .....</b>	<b>45</b>
	<b>Terms and Conditions .....</b>	<b>49</b>
	<b>Return Policy .....</b>	<b>51</b>
	Credits .....	51

# Section 1

## General Information

---

### Introduction

To ensure the best results and service, please read and fully understand this manual prior to putting this pump into service. For any questions regarding operation, maintenance, or installation, please contact your local distributor or Ampco Pumps Company:

Ampco Pumps Company  
2045 W. Mill Road, Glendale, WI 53209  
Phone: (800) 737-8671 or (414) 643-1852  
Fax: (414) 643-4452  
Email: [ampcoocs@ampcopumps.com](mailto:ampcoocs@ampcopumps.com)

### General Information

Each Ampco ZP3 pump is fully assembled, lubricated, and tested at the factory and shipped ready for use. Standard maintenance practices are outlined in this manual. For more information, please refer to the Maintenance section on *page 17*. Following these guidelines will provide long-lasting, trouble-free service when the pump(s) is incorporated in a properly designed system.

### Pump Receiving

Ampco covers the pump inlet and discharge ports prior to shipping, ensuring that foreign matter does not enter the pump during shipment. If the protective covers are missing upon arrival, remove the pump cover and inspect to ensure it is free from contaminate before turning the shafts. Please make note of the pump serial number; this will assist in the process of ordering replacement parts and/or a warranty claim. For more information regarding shipment damage or warranty, please refer to Terms and Conditions (*page 49*).

### Shipping Damage or Loss

Upon receiving equipment that is damaged or if your shipment is lost in transit, immediately file a claim with the carrier. At time of pick-up, the carrier signed the bill of lading, acknowledging that they have received the product from Ampco in good condition.

### Label Information

**▲Warning**

Labels are installed on the pump at the factory to ensure proper warning to users.

Do not remove these labels; doing so may result in injury.

The pump is installed with simple, but effective labels to help the customer better understand the ZP3 pump. An identification plate is applied at the factory to help track the life of the pump. The customer should be aware of the pump's serial number and model number prior to contacting Ampco with any concerns. These labels can be seen in *Figure 1*.

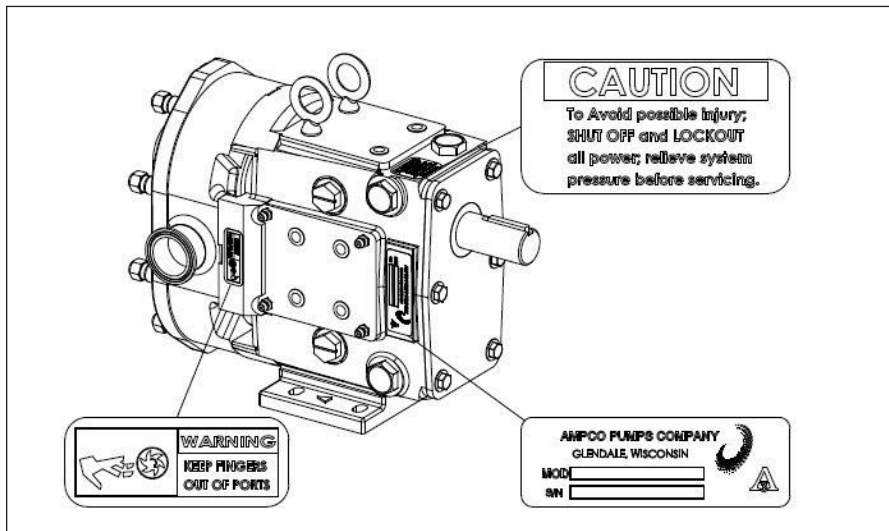

Figure 1. Important Label Information

## Section 2

### Pump Information

#### Pump Design

The design of the ZP3 pump gear case allows for the shaft location to be universal in order to fit any system requirement. This can be seen in *Figure 2* and *Figure 3*.

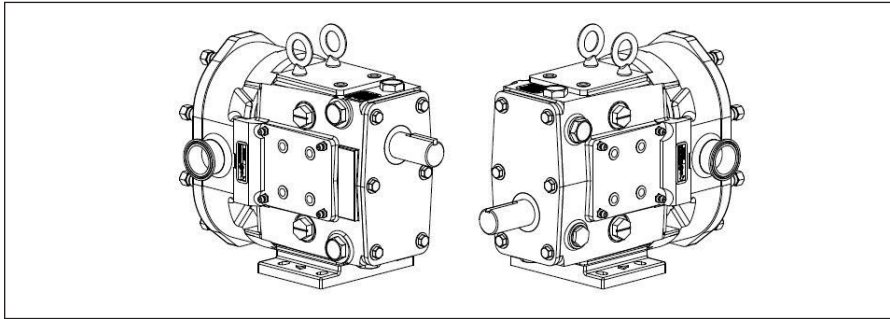

*Figure 2. Shaft Mounts (Upper and Lower)*

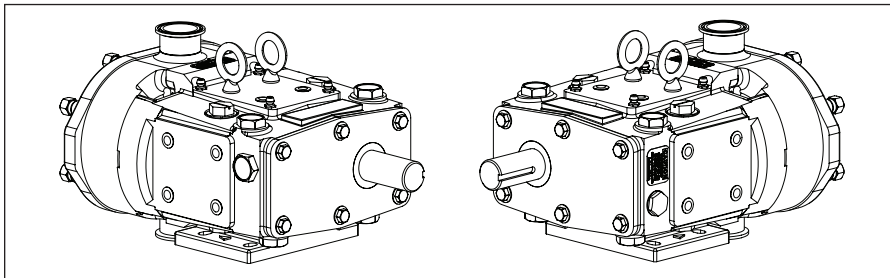

*Figure 3. Shaft Mounts (Left and Right as Viewed from the Front)*

#### Operating Parameters

**Table 1. Standard Operating Parameters**

Model	Maximum Nominal Capacity		Displacement		Maximum Differential Pressure		Temperature Range		Standard Connection Size		Optional Connection Size		Maximum Speed
	GPM	m <sup>3</sup> /hr	Gal./100 rev	Liters/rev	PSI	Bar	° F	° C	in.	mm	in.	mm	RPM
ZP3 6	8	1.8	0.8	0.030	300	21	-40° to 200°	-40° to 93°	1.5	38	1.0	25	1000
ZP3 15	11	2.5	1.4	0.052	250	17			1.5	38	-	-	800
ZP3 18	20	4.5	3.0	0.108	200	14			1.5	38	2.0	51	700
ZP3 30	36	8.2	6.0	0.227	250	17			1.5	38	2.0	51	600
ZP3 40	46	10.4	7.6	0.288	150	10.3			2.0	51	2.5	64	600
ZP3 45	58	13.2	10.0	0.366	450	31			2.0	51	-	-	600
ZP3 60	90	20.4	15.0	0.568	300	21			2.5	64	3.0	76	600
ZP3 130	150	34.1	25.0	0.946	200	14			3.0	76	4.0	102	600
ZP3 180	230	52.2	38.0	1.450	450	31			3.0	76	-	-	600
ZP3 210	300	68.1	50.0	1.900	500	34			4.0	102	-	-	600
ZP3 220	310	70.4	52.0	1.980	300	21			4.0	102	-	-	600
ZP3 320	450	102	75.2	2.847	300	21			6.0	152	-	-	600

**Table 2. Rectangular Flange Model Operating Parameters**

Model	Maximum Nominal Capacity		Displacement		Maximum Differential Pressure		Temperature Range		Rectangular Inlet (W x L)	Outlet		Maximum Speed
	GPM	m <sup>3</sup> /hr	Gal./100 rev	Liters/rev	PSI	Bar	° F	° C	in.	in.	mm	RPM
ZP3 34	24	5.4	6.0	0.22	250	17	-40° to 200°	-40° to 93°	1.75 x 6.75	2.0	50	400
ZP3 64	60	13.6	15.0	0.57	300	21			2.24 x 8.82	2.5	65	400
ZP3 134	100	22.7	25.0	0.96	200	14			2.97 x 9.25	3.0	76	400
ZP3 184	152	34.5	38.2	1.43	450	31			3.28 x 11.25	3.0	76	400
ZP3 214	200	45.4	50.2	1.90	500	34			3.45 x 12.70	4.0	102	400
ZP3 224	208	47.2	52.1	1.97	300	21			3.87 x 11.00	4.0	102	400
ZP3 324	401	91	75.2	2.75	300	21			4.25 x 12.70	6.0	152	400

- For operating parameters that fall outside the standard values defined in *Table 1* and *Table 2*, please contact the Engineering Department at Ampco Pumps Company (414-643-1852).
- Standard rotors operate within a temperature range of -40°F to 200°F. Hot clearance rotors operate between 180°F to 300°F. Consult Ampco for questions on application factors such as temperature, operational speed, and differential pressure.

**⚠ Caution**

Noisy pump operation may result from cavitation, air/gas in product, rotor to body contact, rotor to rotor contact, or external mechanical problems. See the Troubleshooting section, under “Noisy Operation” for corrective measures that may be taken to avoid injury from excessive sound pressure. Wear ear protection when levels may exceed 80 dBA.



## Section 3 Installation

### Installation

Follow local codes and restrictions when installing the pump and piping system. The practices outlined in this manual are intended to ensure the most optimal performance of the pump.

#### ⚠ Caution

Use vibration isolation pads to reduce noise and vibration. Failure to reduce vibration as needed could cause minor or moderate injury.

### Base Arrangement

The standard installation arrangement for a pump of this type consists of both the pump and drive unit mounted on the same base plate. Typical base plate arrangements consist of permanently fixed bases, bases with leveling and/or vibration isolation pads,

bases with attached adjustable legs, or portable/wheeled bases. All base arrangements must be level during operation. Standard base configurations (base, pump, coupling, coupling guard, gear reducer, and motor) can be seen in *Figure 4*.

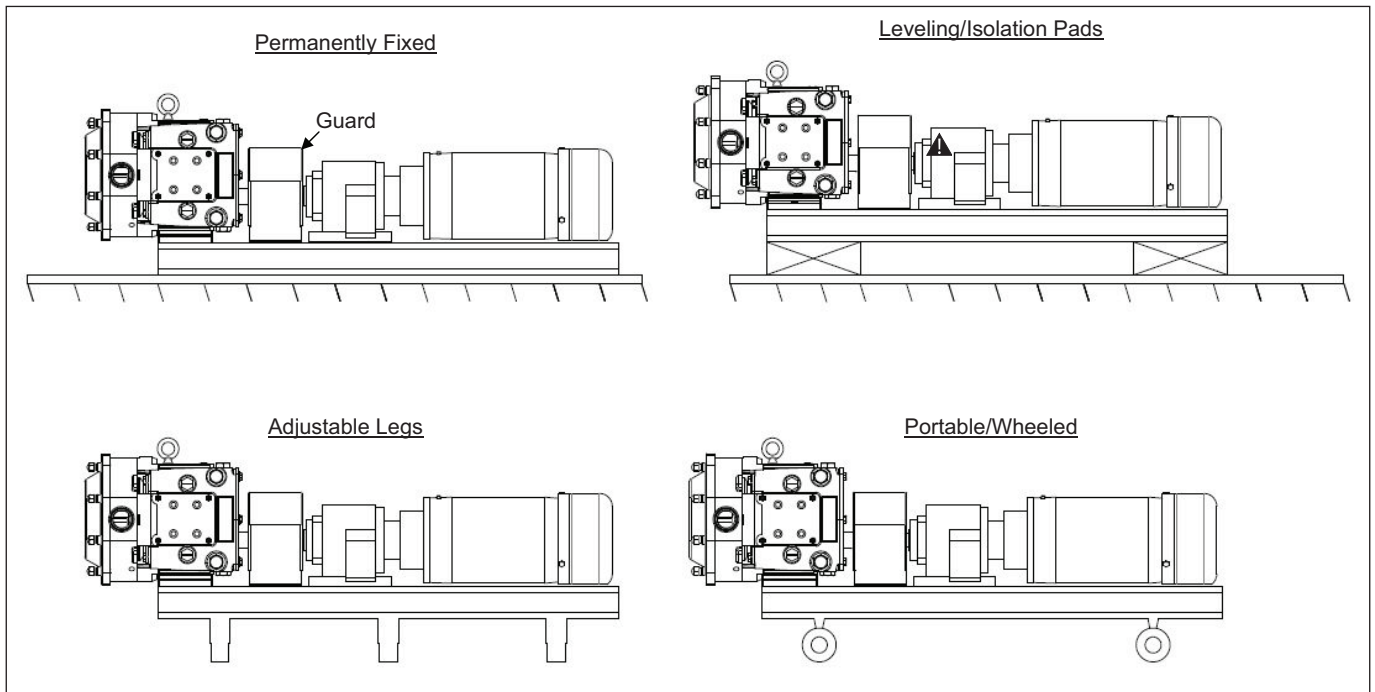

Figure 4. Base Layout Examples

#### ⚠ Warning

To ensure safety, protective guards must be properly installed over all external rotating parts and components. Failure to do so may result in injury. Ampco provides protective guards for complete base packages (pump and drive unit).

### Piping and Connections

It is important to minimize forces imposed on the pump. This can be done by independently supporting the piping going to and from the pump. Excessive force applied to the pump can cause misalignment of internal

parts which leads to the premature wear of rotors, bearings, and shafts. The use of hangers and pedestals on connecting pipes will help avoid such misalignment. Examples of such supports can be seen in *Figure 5*.

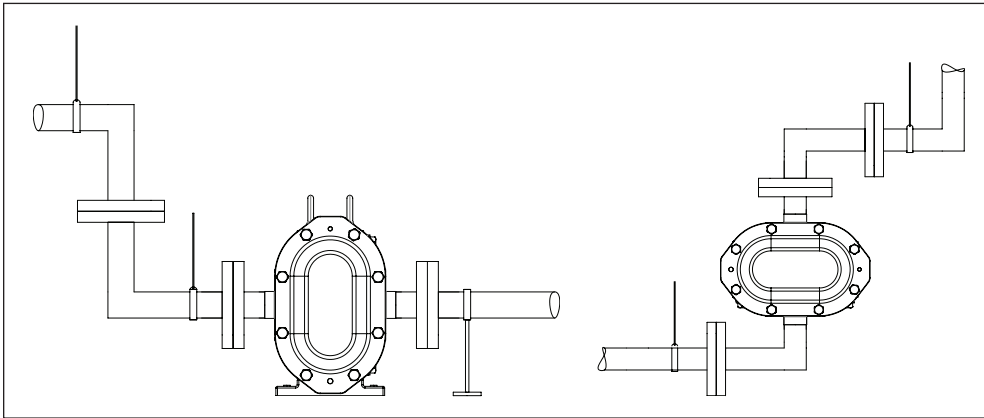

Figure 5. Piping Support Example

It is not recommended to weld custom fittings outside the factory. Shrinkage and warpage can occur to the pump housing which will affect the life and performance of the pump.

To prevent air pockets from entering the pump from the inlet, install the pump below the supply (*Figure 6*). This will create a constant supply of product on the suction side, and reduce the chance for air to enter the pump. Sloping the piping on the inlet side away from the pump will prevent air pockets if the pump is installed above the supply (*Figure 7*).

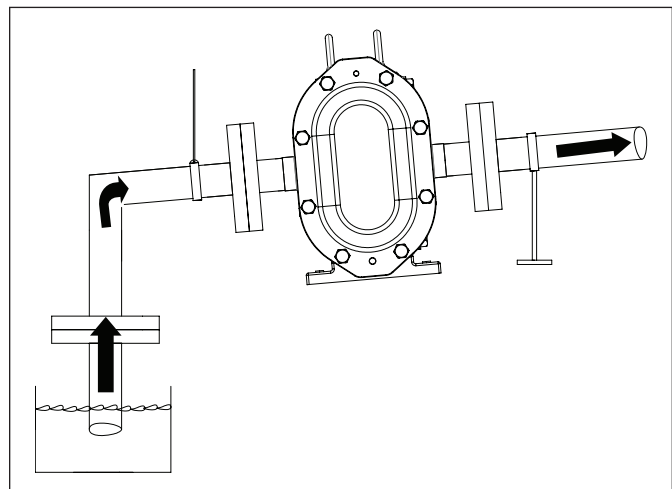

Figure 7. Correct Piping (Supply Below)

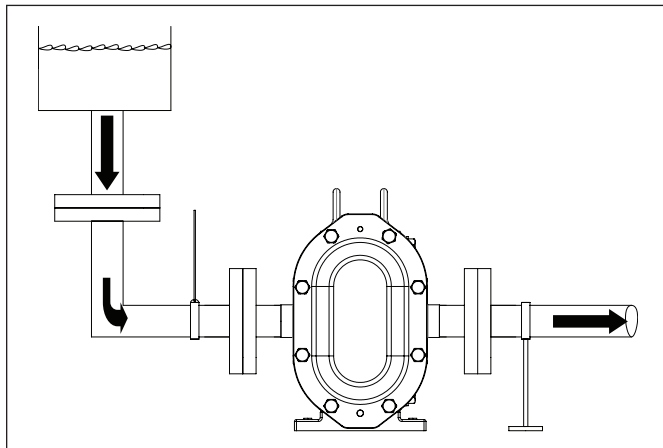

Figure 6. Correct Piping (Supply Above)

Always verify all electrical devices connected to the equipment are properly grounded to avoid risk of potential corrosion from stray current.

### Check/Isolation/Relief Valves

Check valves should be used on the inlet side for any application when the product is lifted (Figure 8). This is to ensure a full inlet and is especially important with low-viscosity fluids. If the system has liquid under a vacuum, such as closed tank applications, it is important to have a check valve on the discharge side to prevent backflow during initial start-up (Figure 9).

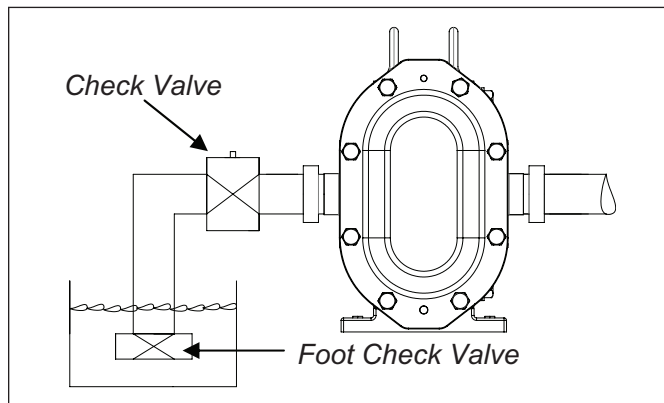

Figure 8. Check Valve (Inlet Side)

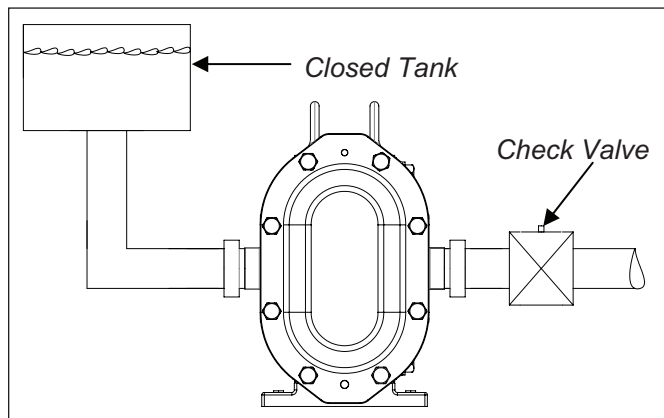

Figure 9. Check Valve (Discharge Side)

When shutdown time is not possible, a bypass system may be installed with a backup pump in parallel series to allow production to continue while maintenance is performed on the down pump. Isolation valves may also be used on both the inlet and discharge sides of the pump to shut down the flow of product to the pump. This will allow for maintenance and removal of the pump without draining the entire system and risking the loss of product.

#### Notice

Ampco's ZP positive displacement pumps are designed with extremely tight tolerances allowing only low slip internally between rotors and pump housing. DAMAGE will occur if the pump is operated with discharge or inlet lines closed. DO NOT operate pump with lines closed.

In order to prevent damage to the pump, it is recommended a relief valve be installed on the pump's discharge side. The relief valve can either divert flow into a drain or back to the inlet side (Figure 10).

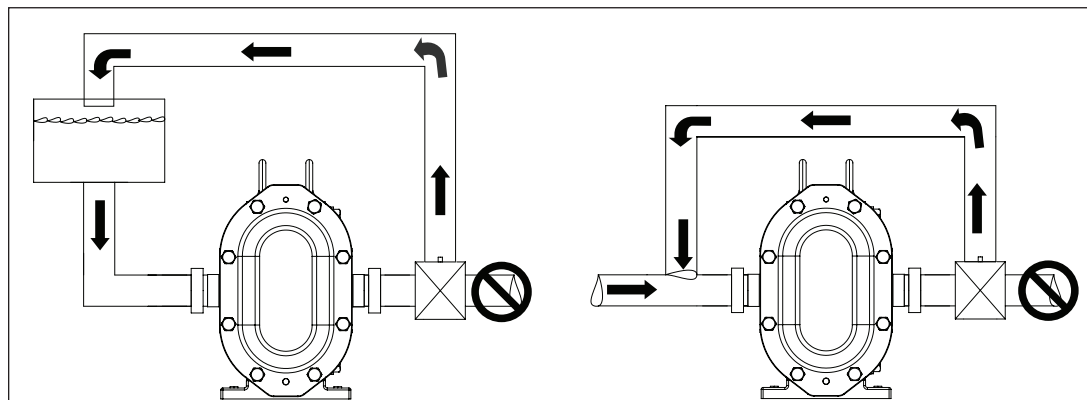

Figure 10. Relief Valve Examples

### Strainers and Gauges

Strainers and magnetic traps should be used to prevent foreign matter from entering the pump. It is essential to service strainers and traps regularly to prevent restriction of flow. To determine the performance of the pump, install pressure and vacuum gauges on the inlet and discharge piping (*Figure 11*).

#### Proper Gauging Shows:

- Unusual pressure variations
- Indicates flow
- Changes in pump performance
- Variations in the system
- Differences in fluid viscosities

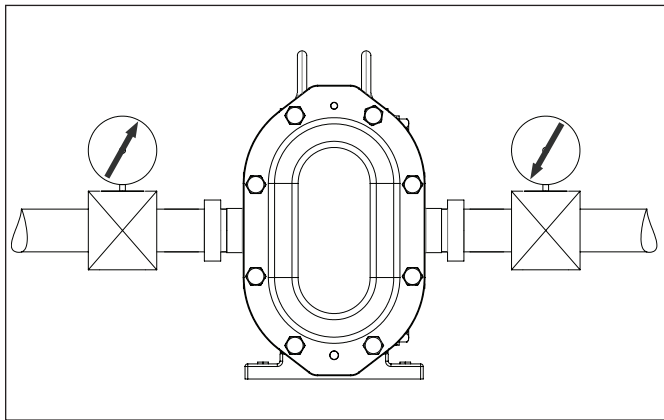

Figure 11. Proper Gauging

### Base Alignment

Pump and base assemblies sent directly from Ampco's factory are aligned prior to shipment. Assemblies must be checked once they are installed and prior to operation. Misalignment may cause unnecessary wear and shorten the life of the pump. If couplings are not specified, Ampco will use a flexible coupling which permits minor compensation for alignment and endplay.

To check the coupling alignment, start with checking the angular alignment by measuring the gaps between the couplings on both the pump and motor side (*Figure 12, Angular Alignment*). Shim the assembly accordingly so the gap is equal distance at all points. Next, using a straight edge, check the horizontal and vertical alignment of the coupling. Place the straight edge along the coupling to ensure that both sides are concentric (*Figure 12, Parallel Alignment*).

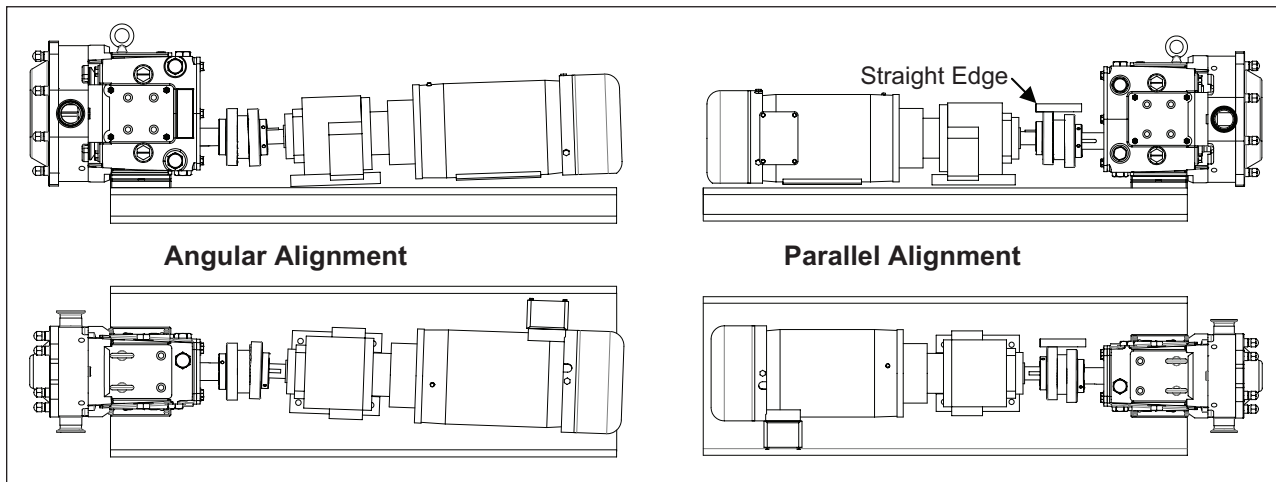

Figure 12. Check Alignment

## Pump Rotation

Check the direction of rotation (both on drive unit and pump) prior to connecting the pump to the drive. This will ensure correct product flow at start-up (*Figure 13* and *Figure 14*). Also check that the pump turns freely and is free of any foreign contaminants. Connect the pump and check to make certain all guards are in place.

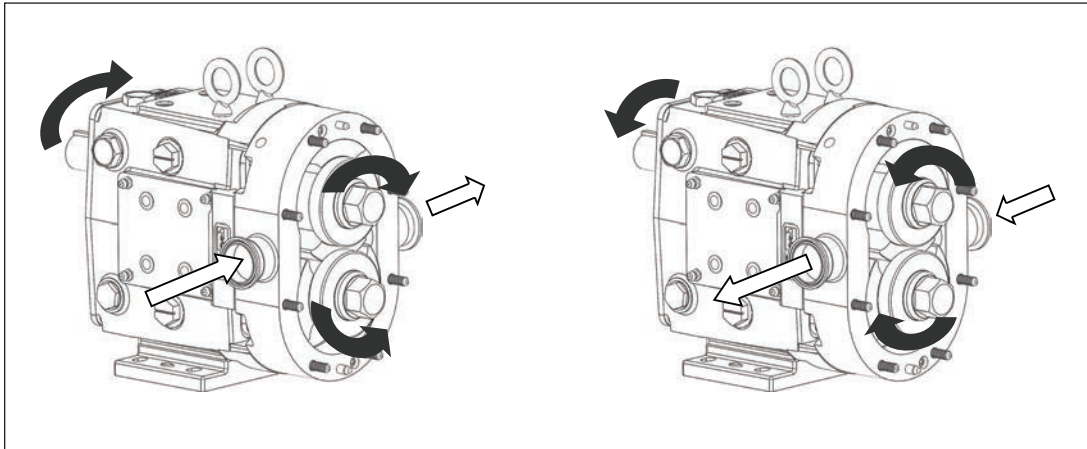

Figure 13. Top Drive Shaft

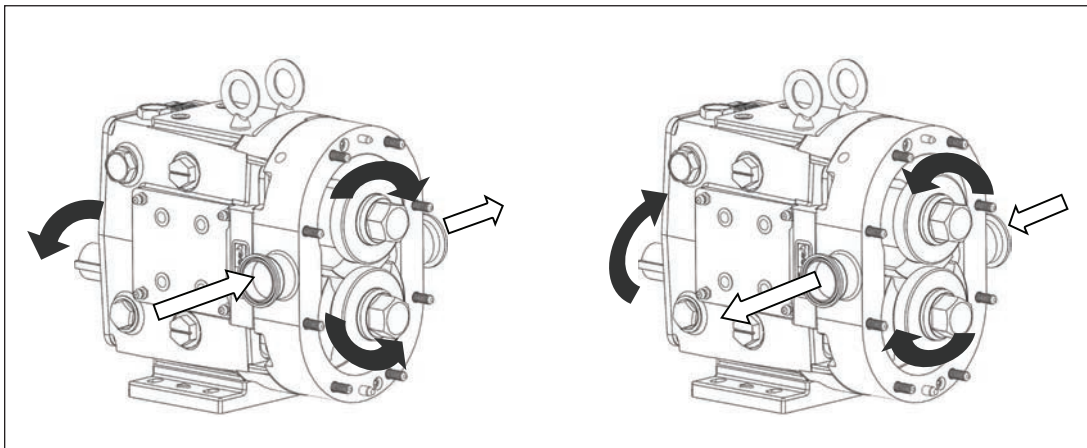

Figure 14. Bottom Drive Shaft

### Seal Flushing

For pumps with double seals, connect seal flushing before operation. Operation of the pump without proper flushing will **damage** seal faces. Flushing connections are typically 1/8" female NPT with one side being the inlet and the other the discharge. Flush from the bottom to the top, using the lower connection as the inlet and the upper connection as the discharge. This ensures that air is removed from the flush line with the flush area completely flooded (*Figure 15*). Flush flow rate should be 1/4 GPM (30 psi max pressure). For high temperature applications flush flow may be increased to remove excess heat.

ZP3 is capable of a barrier pressure no more than 10-15 psi above the process pressure. Keep in mind a small amount of the barrier fluid will enter the pumped liquid, therefore the barrier fluid must be compatible with the product.

*\*Maximum Barrier Pressure is 100 psi*

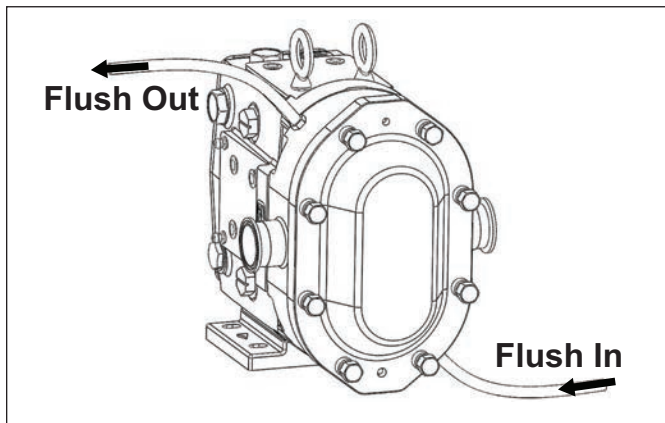

*Figure 15. Proper Flushing for ZP3 Double Seal*

### Pre-Start-Up Checklist

**⚠Caution**

DO NOT flush a new system for the first time with this pump. Severe damage may be caused to the pump from debris during start-up, which could result in injury. Remove the rotors during system flushing to prevent any debris from getting trapped between rotors and pump body.

**⚠Warning**

All guards must be installed to protect operators and maintenance personnel from the rotating components. Guards are supplied as part of pump and motor full assemblies. The gap between the pump body and gearcase is required for 3-A sanitary standards.

**⚠Warning**

Do not start a pump with a seal flush unless the seal flush is installed and on.

1. Review setup and make sure the pump is correctly installed as described in Section 3 "Installation" on page 9. Review "Check/Isolation/Relief Valves" on page 11 and install valves as needed.
2. Check the coupling alignment. See base and coupling alignment on page 12.
3. Check the pump and piping and make sure they are clean and free of any foreign material.
4. Make sure that all piping connections are secure and leak-free. If possible, checking the system with non-hazardous fluid like water is advisable.
5. Double check the pump and drive to see if they are adequately lubricated. See "Pump Lubrication" on page 17.
6. Check that all guards are secured properly and in place.
7. Ensure double mechanical seals have proper supply and flow of clean fluids when flushing.
8. Make sure all valves are open on INLET side and allow fluid to fill the pump. Flooding the suction is recommended on installation.
9. Discharge side valves should be open and free of obstructions.
10. Check the pump and drive rotation to verify the correct product flow at start-up. See "Pump Rotation" on page 13.

## Start-Up Procedure

### **▲Warning**

Pump damage could result in death or serious injury.

- Do not run the motor with the pump dry, which causes damage to pump components.
- Do not obstruct the outlet of the pump. Obstruction will result in increased system pressure, above the specified maximum pressure of the pump.
- Do not introduce sudden extreme product temperature changes to the pump (temp flashing). Gradually adjust the temperature of the pump components or the product.

NOTE: Sanitize the pump before start-up for sanitary applications.

1. Start the pump slowly.
2. When the pumphead is filled with product, stop the pump and allow the pump's fluid components to thermally adjust to the product temperature for 15 minutes.
3. Re-start the pump.

## Shutdown Procedure

1. Disconnect the pump from the drive.
2. Disconnect the supply and discharge lines.

## Emergency Shutdown Procedure

Emergency Shutdown is dependent on system requirements. Document the procedure after assessment of the application.

THIS PAGE INTENTIONALLY LEFT BLANK



## Section 4 Maintenance

### Maintenance

**⚠Warning**

Shut off and lockout all power and relieve system pressure before servicing to prevent accidental start-up and injury.

**⚠Warning**

Make sure the pump is secured prior to performing maintenance. As components are removed or added, tipping could occur.

**⚠Caution**

Only trained personnel should perform maintenance.

The Ampco ZP3 pump is designed to be easily disassembled for cleaning and maintenance purposes. When performing maintenance on the pump it is important to inspect all wetted parts for standard wear and damage. For inspection instructions please see *page 18*. For rebuild information, see PD Pump Remanufacturing Program details on *page 41*. Prior to disconnecting pump, shut off all inlet and discharge valves, drain the pump (rinse if necessary), and turn off all electrical supply to the pump (follow standard lockout procedures).

### Pump Lubrication

Proper lubrication of gears and bearing is vital to the life of the pump. For pumps assembled on bases with a gear reducer and motor, please refer to the proper manufacturer manual for lubrication requirements. These manuals are sent with the pump from the factory. Important pump lubrication points can be seen in *Figure 16*.

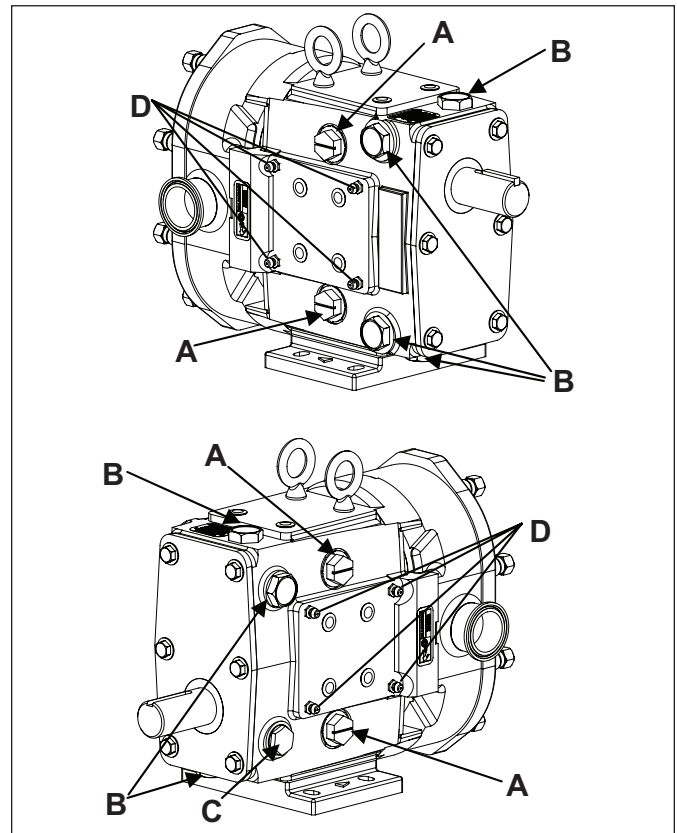

*Figure 16. Lubrication Points*

Item No.	Part	Qty.
A	Clean-out Plugs	4
B	Oil Plug (Drain and Fill)	5
C	Sight Glass	1
D	Grease Fittings	8

Both gears and bearing are shipped factory-lubricated with grease and oil. The oil used to lubricate the gears should be changed every 500 hours with the quantities shown in Table 3. The bearings should be re-greased every 250 hours. Excessive grease may build up inside the gear case and should be cleaned out through the clean-out plugs shown in *Figure 16, A*.

**Table 3. Oil Capacity (Gears) and Grease Quantity (Per Bearing)**

ZP3 Model	Oil Capacity (Gears)		Grease Quantity (Per Bearing)	
	Top/Bottom Shaft	Side Mount	Front	Rear
6, 15, 18	1.3 oz (40 ml)	3.3 oz (100 ml)	0.37 oz (11 cc)	0.13 oz (4 cc)
30, 34, 40	2.0 oz (60 ml)	4.0 oz (120 ml)	0.60 oz (18 cc)	0.21 oz (6 cc)
45, 60, 64, 130, 134	6.0 oz (170 ml)	9.5 oz (280 ml)	0.84 oz (25 cc)	0.76 oz (22 cc)
180, 184, 220, 224	11 oz (320 ml)	20 oz (600 ml)	1.33 oz (39 cc)	1.03 oz (30 cc)
210, 214, 320, 324	17 oz (500 ml)	44 oz (1300 ml)	1.96 oz (58 cc)	1.16 oz (34 cc)

**Oil Specifications:**

ISO Grade 320, SAE 140 or AGMA Number 6EP

**Grease Specifications:**

Halo-Guard FG-2, NSF H1 FOOD-GRADE, NLGI Grade No. 2

\*Replacement oil and grease is available from Ampco.

**Preventive Maintenance/Inspection**

**⚠ Caution**

Handle the rotors, piping, and other pump components carefully as edges may be sharp. Wear gloves to avoid injuries.

While performing standard maintenance or cleaning, check for signs of damage or extreme wear. A simple inspection may show signs of a problem long before it becomes serious. Detection of such problems can avoid costly repairs and reduce down time.

Remove the cover and inspect the rotor tips to ensure that there is no metal-to-metal contact between the rotors. Measure the clearance between the rotor tips as seen in *Figure 17*. The clearance should be equal on both sides. If contact is detected, rotors may require replacement.

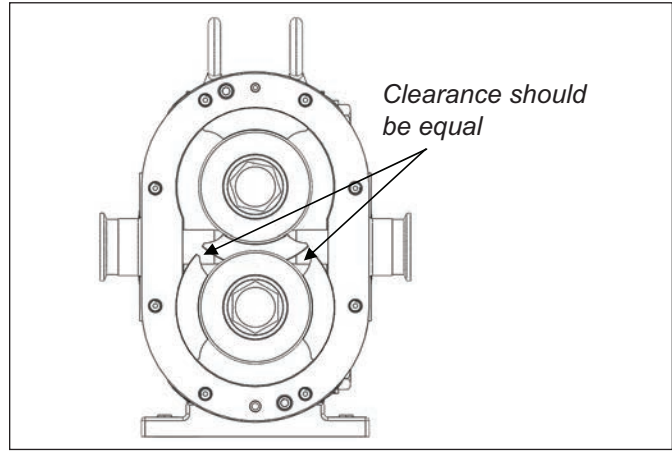

*Figure 17. Clearance Between Rotor Tips*

Inspect the shaft shoulder and shaft keyway (*Figure 18*) for wear and replace, if necessary.

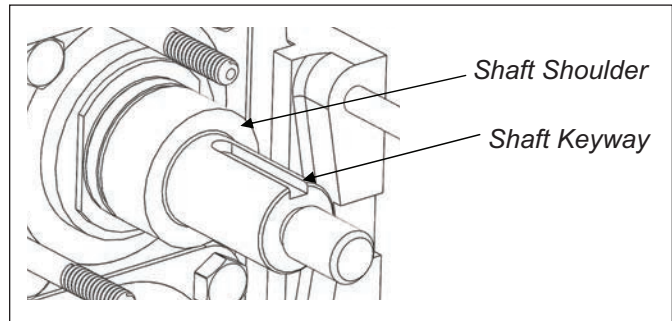

*Figure 18. Shaft Inspection Points*

Inspect the rotor hub and rotor keyway (*Figure 19*) for wear and replace, if necessary. Rotor and shaft wear at these locations is caused by extended operation with loose rotor nuts.

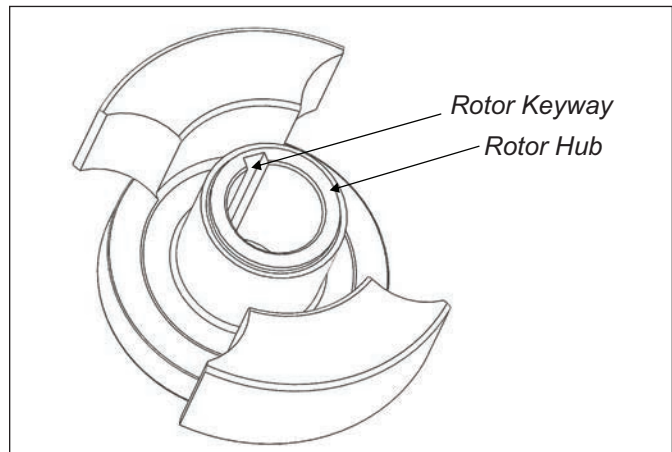

*Figure 19. Rotor Inspection Points*

## Gear and Bearing Inspection

### ⚠ Caution

Temperatures may vary depending on product. To avoid injury, allow the gear case to warm or cool before handling.

While the fluid end is disassembled, feel for gear backlash (play between the gears) by rotating either shaft. Once turning has started the other shaft must engage (*Figure 20*). If gear backlash is present remove the gear casing cover (drain oil first, see *page 30* for disassembly information) and check for wear around the gear teeth. If evidence of gear teeth wear is present, replacement is recommended. If gear(s) are loose, check the shaft key and keyway, either may require replacement.

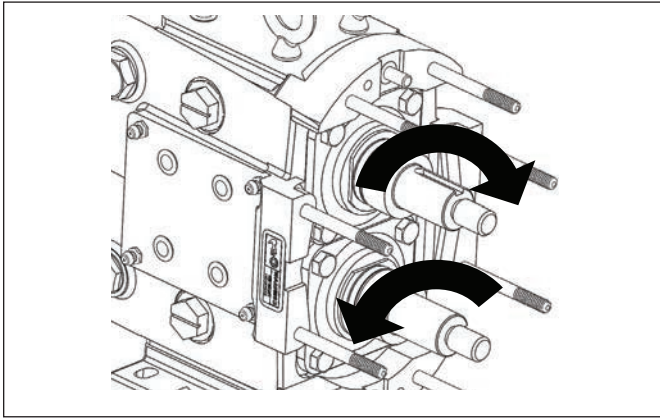

*Figure 20. Check for Gear Backlash*

Next, check the condition of the bearings. Do this by applying force in an up-and-down motion by hand on both shafts (*Figure 21*). Also check for any horizontal movement by pushing and pulling on the shaft. If any movement is felt, the bearing may need replacing. If disassembly of the entire gear case is required, please refer to *page 30* for instructions.

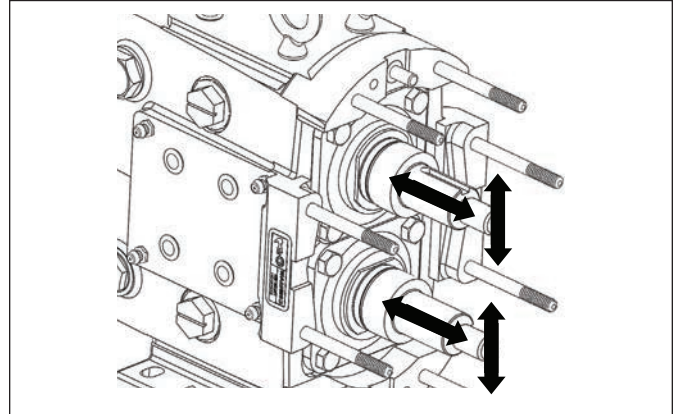

*Figure 21. Check for Bearing Movement*

### Annual Maintenance

**⚠ Caution**

Handle the rotors, piping, and other pump components carefully as edges may be sharp. Wear gloves to avoid injuries.

**⚠ Caution**

Temperatures may vary depending on product. To avoid injury, allow the gear case to warm or cool before handling.

It is important to perform an annual maintenance check of the pump in addition to the preventive maintenance procedures listed on *page 18*. Annual maintenance practices are as follows:

- Check the gear case bearings by measuring the shaft's radial movement with a dial indicator (*Figure 22, A*). If the movement is greater than or equal to the rotor-to-body clearance found on *page 41 (Table 10)* the bearings should be replaced.
- Remove the gear casing cover (see *page 30* for disassembly information) and inspect the gears for wear and damage (*Figure 22, B*). Also check for backlash and looseness.
- Inspect the rotors for signs of wear and stress cracks around the areas defined in *Figure 22, C*. Replace, if necessary.
- Check the pump clearances detailed on *page 41* to determine pump wear. Pump wear can be compensated by increasing pump speed.

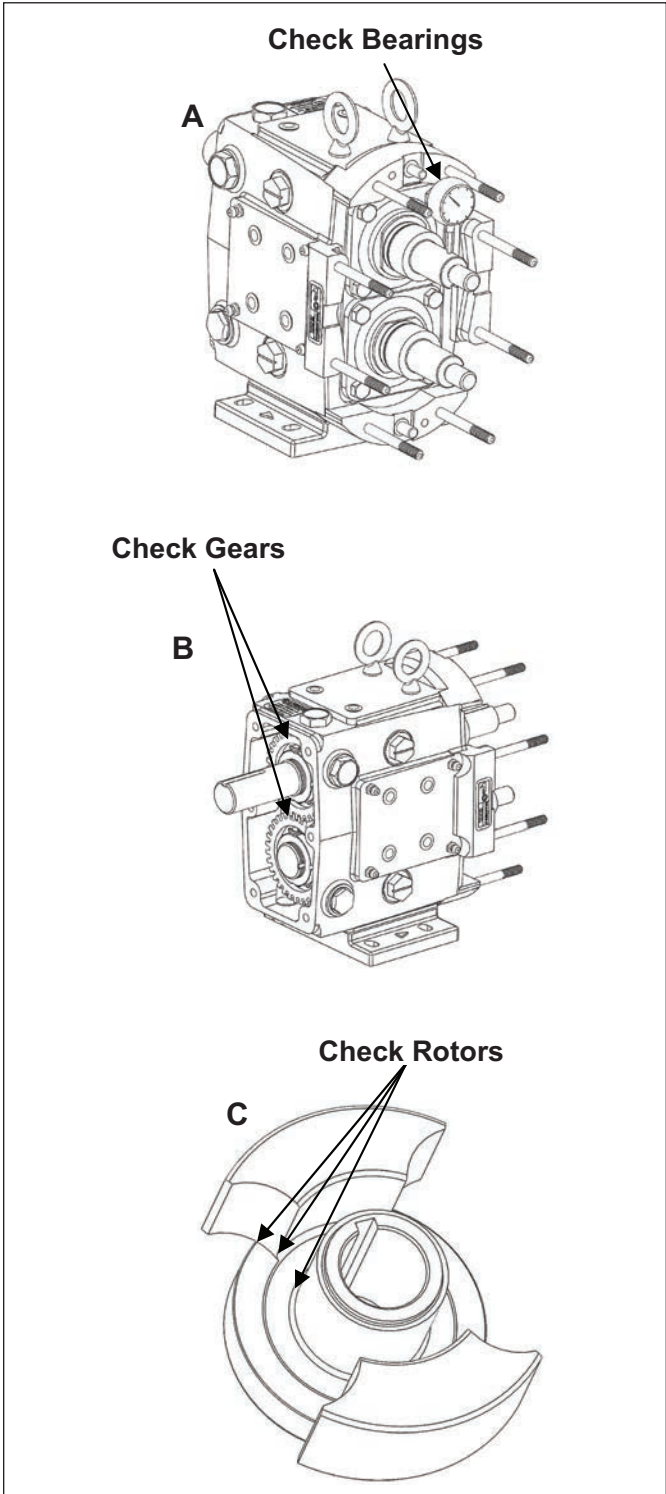

Figure 22. Annual Maintenance Checks

## Cleaning

All wetted parts are designed and manufactured to be acceptable by 3A Sanitary Standards. The body, rotors and seals can be easily disassembled and cleaned simply by removing the cover and rotor nuts. Pump disassembly information begins on *page 21*.

### ⚠ Caution

Strong cleaning solutions are harmful to hands. Wear appropriate gloves to avoid injury.

### Notice

Do not use abrasive cleaning tools and chemicals. Wire brushes or pads will physically damage metal and seal parts.

Once the fluid end is disassembled, follow standard practices for cleaning the product being pumped. If for any reason the rotor o-ring should fail and the internal threads of the rotor nut become soiled, a soft bristle brush and appropriate cleaning solution should be used to clean them. Do not use abrasive cleaning tools and chemicals. Wire brushes or pads will physically damage metal and seal parts. Pump parts should not be exposed to harsh acids for longer than necessary. Once the parts have been removed from a cleaning solution, rinse the parts so no residual deposits remain. Acids and cleaning solutions can be harmful. Take necessary steps to prevent bodily harm.

ZP3 pumps are designed for CIP (clean-in-place) without disassembly ensuring that cleaning solution reaches all product-contact surfaces inside the pump. Process connections for EHEDG certified pumps must be in accordance with EHEDG Position Paper: *Easy cleanable Pipe couplings and Process connections*.

To completely drain the pump, it must be oriented with the port centerline perpendicular to the floor. A minimum flow velocity of 5 ft/sec (1.5 m/s) is necessary to sufficiently clean product-contact surfaces. Differential pressure of 30 psi (2 bar) is recommended to achieve this for most applications. For models which cannot achieve the aforementioned requirements, a booster pump and/or bypass loop must be used during CIP. For additional support, please contact the Engineering Department at Ampco Pumps Company (414-643-1852).

## Pump Disassembly

### ⚠ Warning

Shut off and lockout all power and relieve system pressure before servicing to prevent accidental start-up and injury.

### ⚠ Caution

SHUT OFF product supply to the pump and drain the pump before disconnecting piping and disassembly.

### ⚠ Caution

Handle the rotors, piping, and other pump components carefully as edges may be sharp. Wear gloves to avoid injuries.

1. Start by removing the cover nuts using an appropriate wrench (*Figure 23*). During disassembly place all parts on a clean, protected surface with finished surfaces and seal faces facing up. Tap the cover off using a soft mallet. Remove the cover o-ring and inspect.



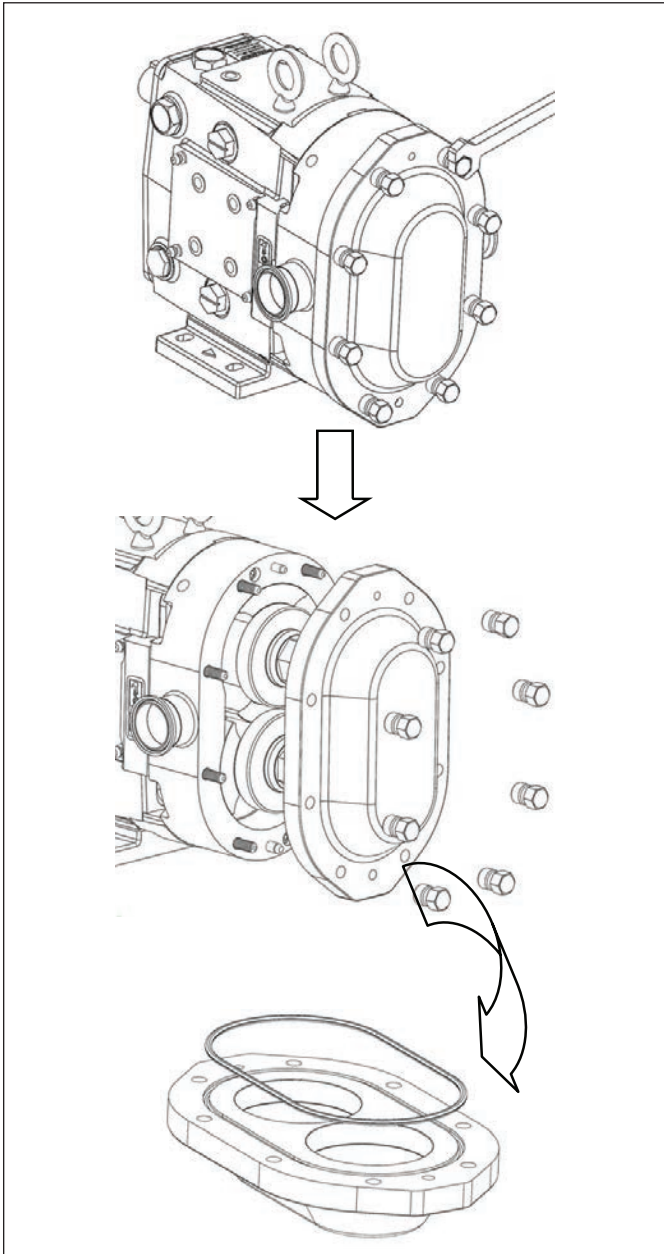

Figure 23. Removing ZP3 Cover

2. Remove the rotor nut assembly using the appropriate size wrench and a non-metallic wedge to keep the rotors from moving (Figure 24). Unthread each nut and disassembly the nut assembly (rotor nut, Bellville washer, and retaining o-rings).

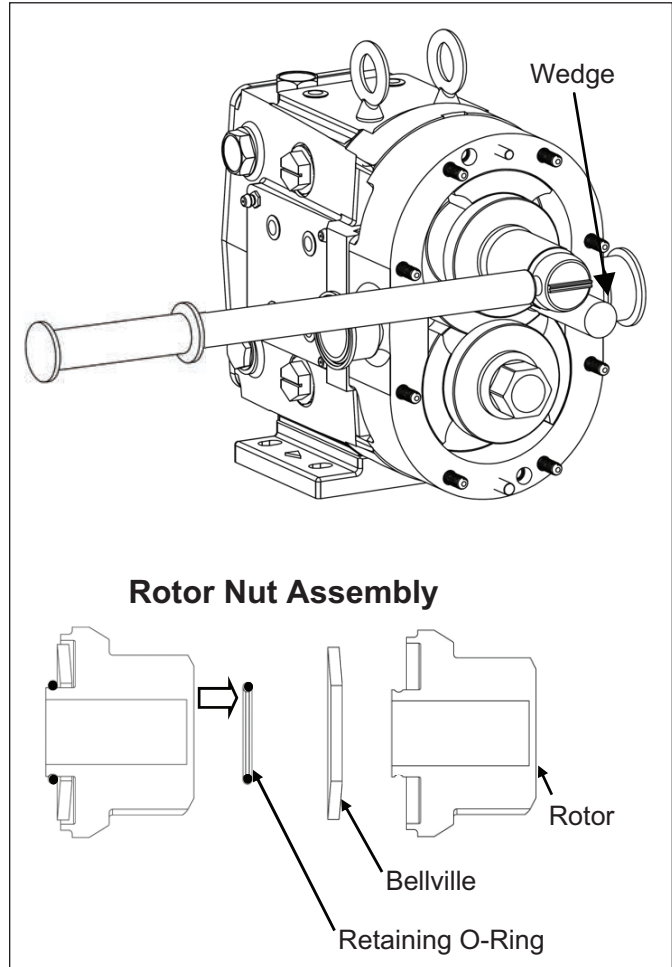

Figure 24. Rotor Removal

3. Remove the rotors by orientating them perpendicular to each other and then pulling them out. It is important to be cautious with the rotors so that they are not damaged. If rotors are difficult to remove, use a nylon or wood lever to pry them out without damaging the body or the rotors. If necessary, remove the body hold down screws and tap the body forward to loosen the rotors. Use (Figure 25) to ensure that all parts are removed.

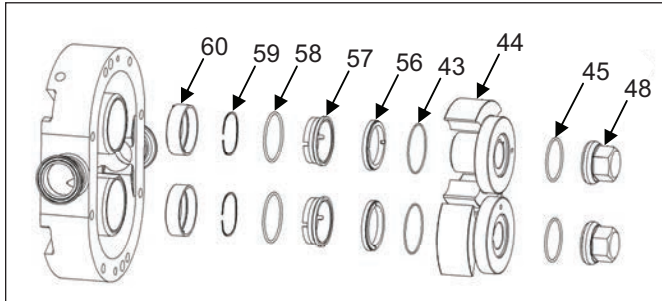

Figure 25. Single Mechanical Exploded View

Item No.	Qty	Description
48	2	Rotor Nut
45	2	O-Ring, Rotor Nut
44	2	Rotor
43	2	O-Ring, Rotor Seal Face
56	2	Rotor Seal Face
57	2	Body Seal Face
58	2	O-Ring, Body Seal Face
59	2	Inner Wave Spring
60	2	Seal Sleeve

- Remove the two body hold-down bolts using the appropriate driver. Pull the pump body off by sliding it along the studs (Figure 26). If the body is stuck, use a soft mallet to tap the body. Inspect the body for excessive wear, clean, and continue on to seal maintenance. It is important to reassemble the pump body back onto the original gear case because the shafts are shimmed for that particular body.

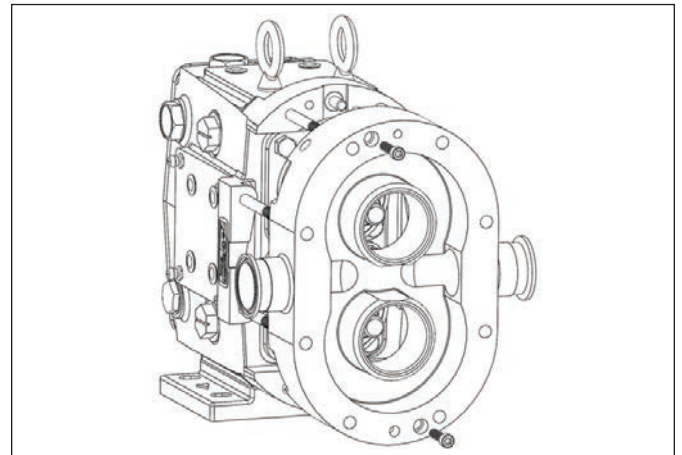

Figure 26. Removing Pump Body

### Seal Maintenance

#### SINGLE MECHANICAL SEAL

1. Start by inserting the wave spring into the sleeve making sure that it sets below the stationary drive pins (Figure 27).

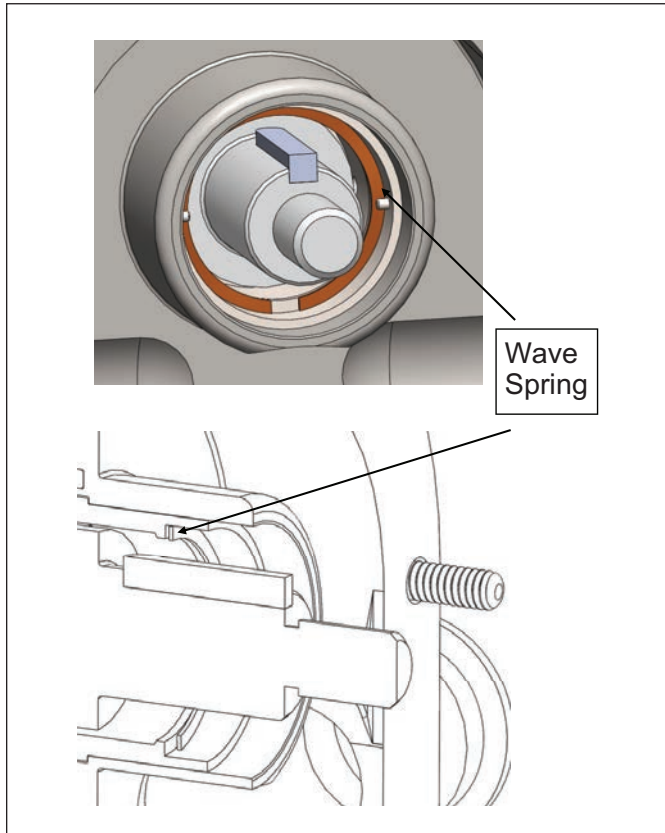

Figure 27. Inserting

2. Slide the stationary seal o-ring into the body hub until it seats against the top of the sleeve (previously installed). Align the slots on the stationary seal with the pins inside the hub. Press the stationary seal into the hub until it seats on the spring; there should be noticeable spring resistance when pushing on the seal (Figure 28).

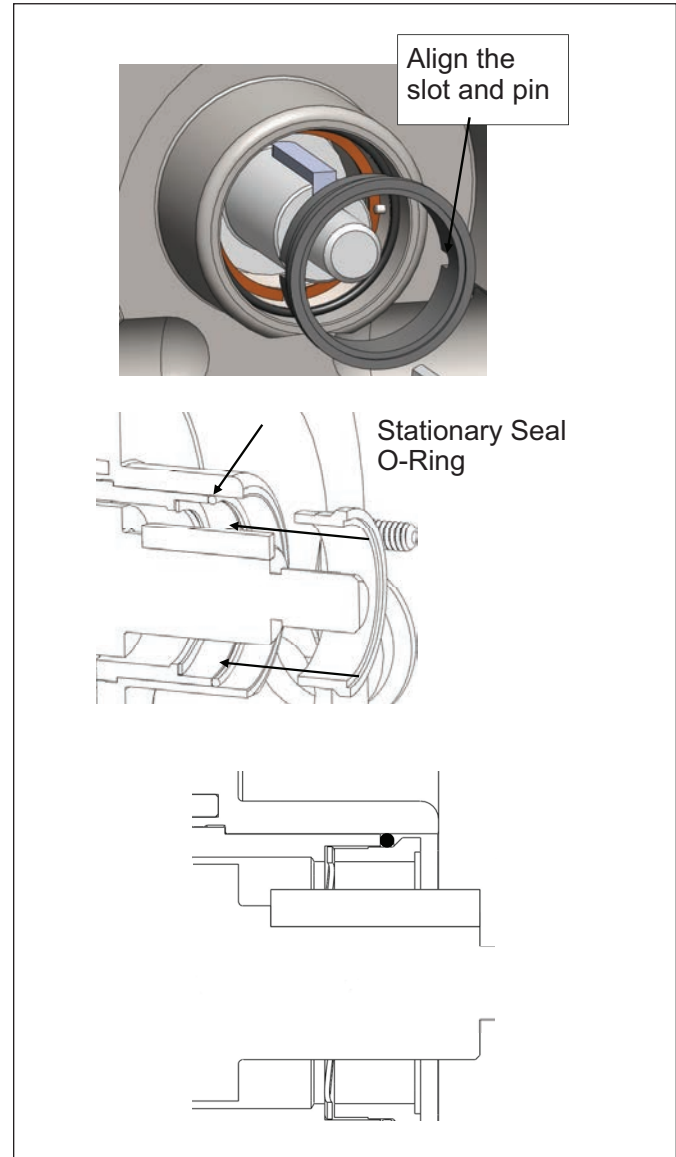

Figure 28. Stationary Seal Assembly



3. Next install the rotating o-ring onto the rotating seal by stretching it (not rolling) onto the rotating seal (Figure 29).

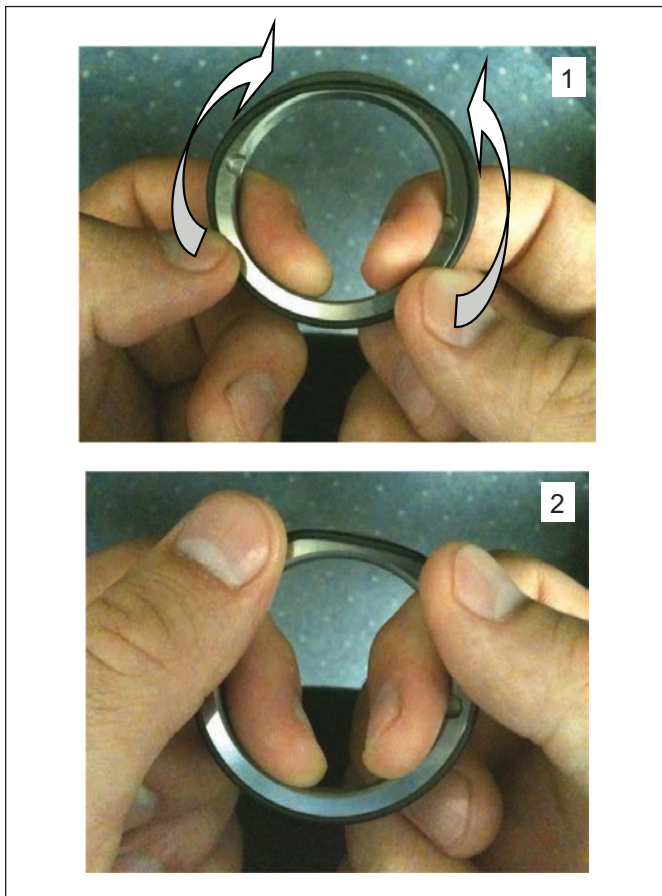

Figure 29. Installing the Rotating O-Ring

4. Slide the rotating seal onto the rotor hub (Figure 30) making sure to align the slots on the seal to the drive pins in the rotor. Press the seal down until it seats inside of the rotor.

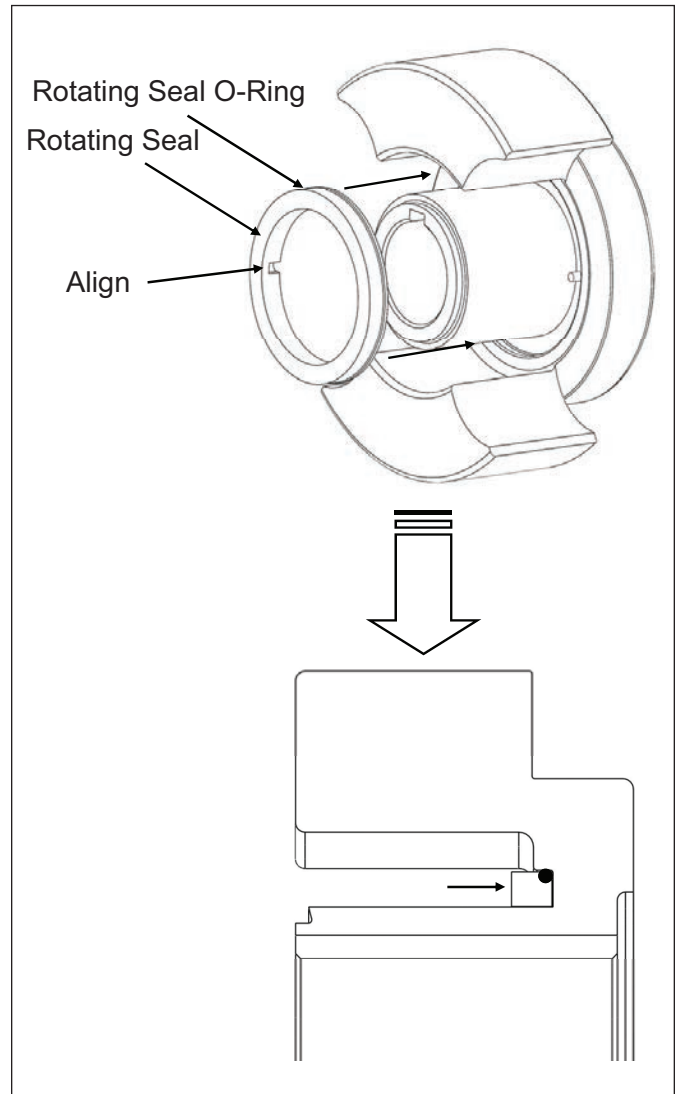

Figure 30. Inserting Rotating O-Ring

- 5. Insert a rotor key in the keyway on the shaft. Slide the rotors onto the shafts until they seat against the shaft shoulder (Figure 31).

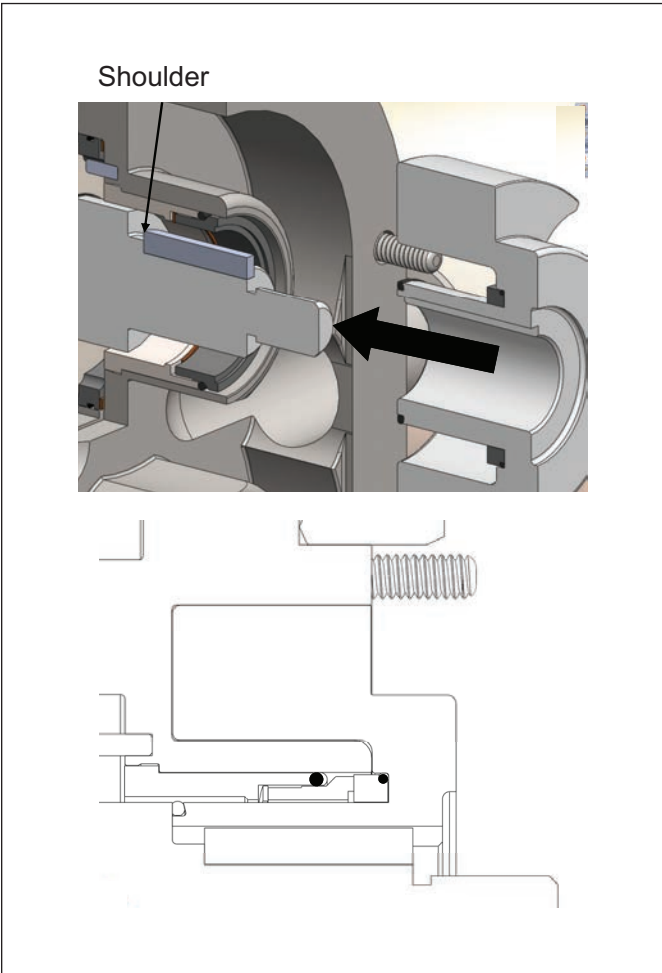

Figure 31. Rotor Assembly

- 6. Install the Bellville washers in the rotor nuts in the orientation shown and hold them in place using the small retaining o-rings (Figure 32). Install a rotor nut o-ring before threading the nut onto the shaft.

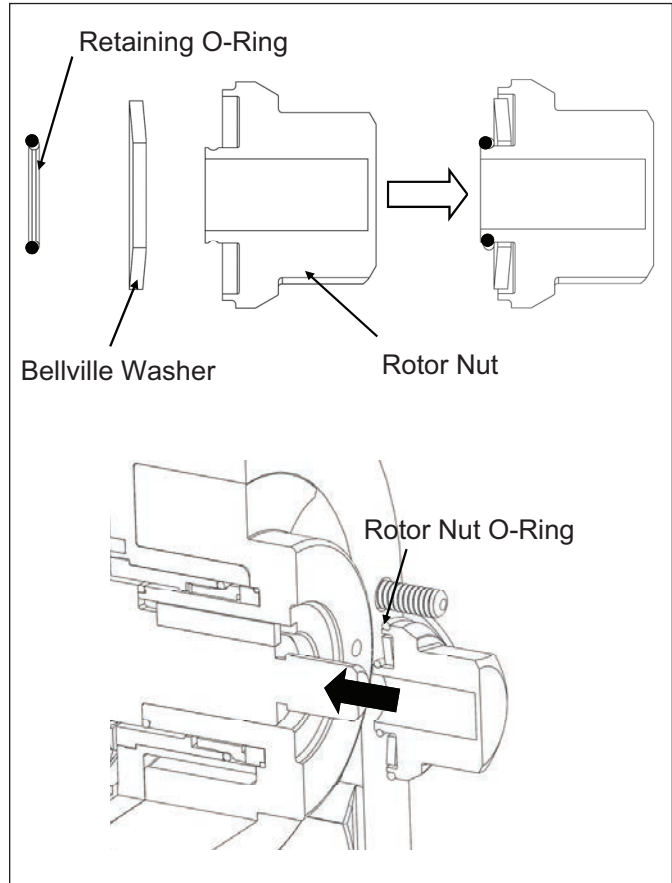
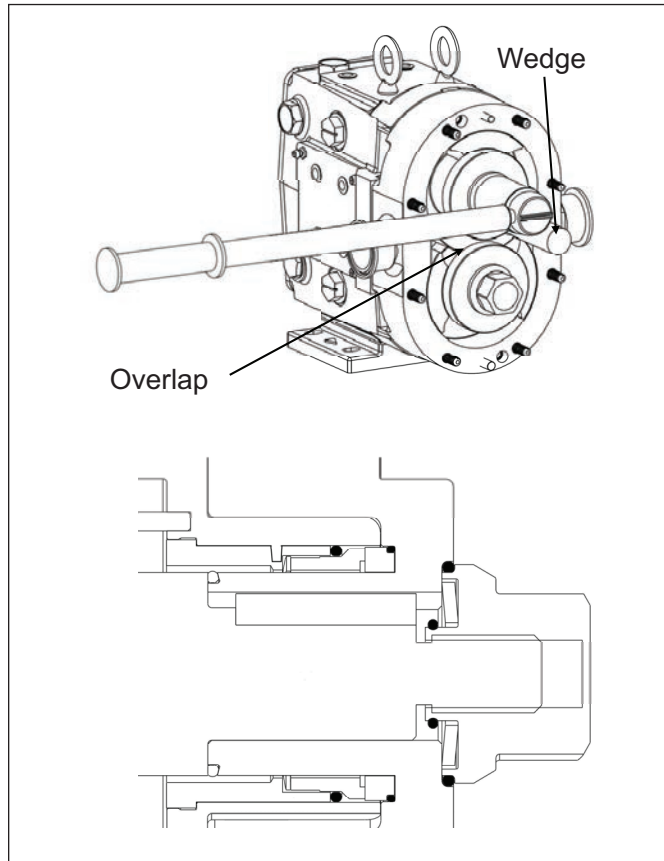

Figure 32. Rotor Nut Assembly

7. Thread the nut onto the shaft and tighten it down using the appropriate wrench and a non-metallic wedge to hold the rotor in place (*Figure 33*). Reference *page 37* for rotor nut torque values. Orientate the rotors as seen in *Figure 33* and Always tighten the first rotor positioned under the overlap of the opposing rotor. Repeat with the second rotor in the same orientation.



*Figure 33. Rotor Assembly*

8. Install a new cover o-ring and slide the cover over the studs making sure that the dowels in the body are aligned with the correct dowel holes in the cover (*Figure 34*). Visually inspect to ensure that the cover o-ring remained in place. Turn the cover nuts (clockwise) by hand and fully tighten them using the appropriate wrench. Tighten the cover nuts in an opposing manner, as seen on *Figure 34*, so that the cover is evenly tightened to the body.

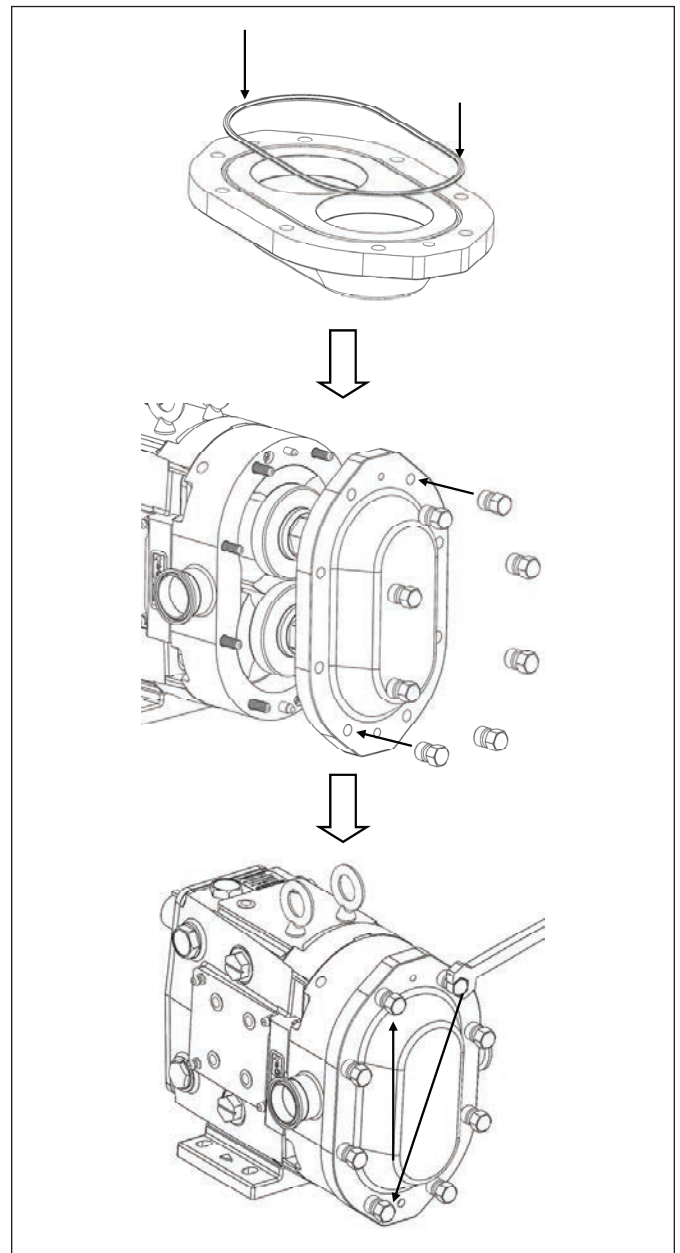

*Figure 34. Cover Assembly*

**DOUBLE MECHANICAL SEAL**

**Disassembly:**

**⚠ Caution**

Use caution not to damage the seals during removal.

1. Remove the Inner stationary seals from the pump body (Figure 35, item 61).
2. Remove the wave springs and stationary o-rings from the stationary seals.
3. Slide the seal seats from each shaft, and remove the seal seat o-ring from the shaft.

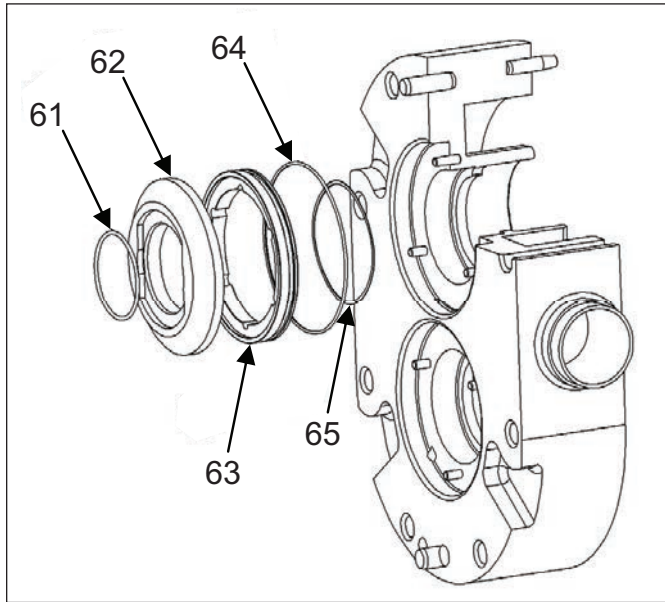

Figure 35.

Item No.	Qty	Description
61	2	Shaft O-Ring
62	2	Seal Seat
63	2	Outer Seal
64	2	O-Ring, Outer Seal
65	2	Outer Seal Wave Spring

**Assembly:**

Clean both shaft ends and the body before assembling. Apply a light film of lubricant to NEW seal seat o-rings and insert them on the shaft's slot. Slide the seal seat onto the shaft by pushing it against the shaft shoulder making sure to align the drive flats on seal seat and shaft (Figure 36).

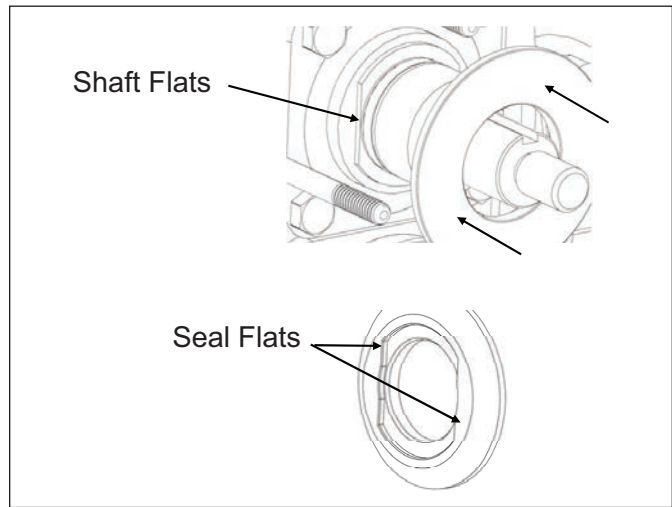

Figure 36. Aligning Flats

Apply a light film of lubricant to NEW inner stationary o-rings and install them on the inner stationary seals. Place the inner wave spring into the body and install the inner stationary seal into the seal groove (Figure 37). Make sure the seal stop pins are aligned with the notches on the inner stationary seal. For double seals, apply a light film of lubricant to NEW outer stationary o-rings and install them on the outer stationary seals. Place the outer wave spring into the body and install the outer stationary seal in the seal groove (Figure 37). Check that the seal stop pins are aligned with the notches on the outer stationary seal.

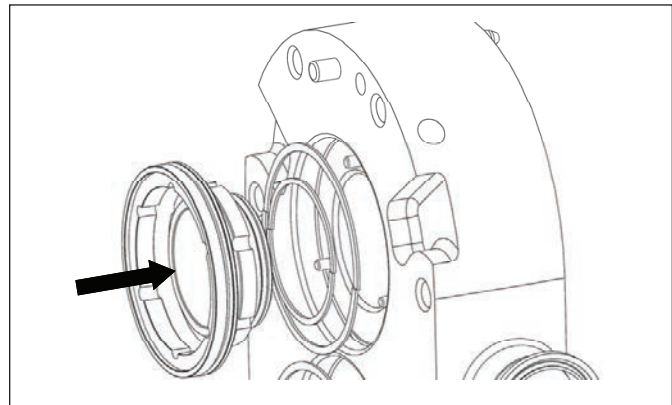
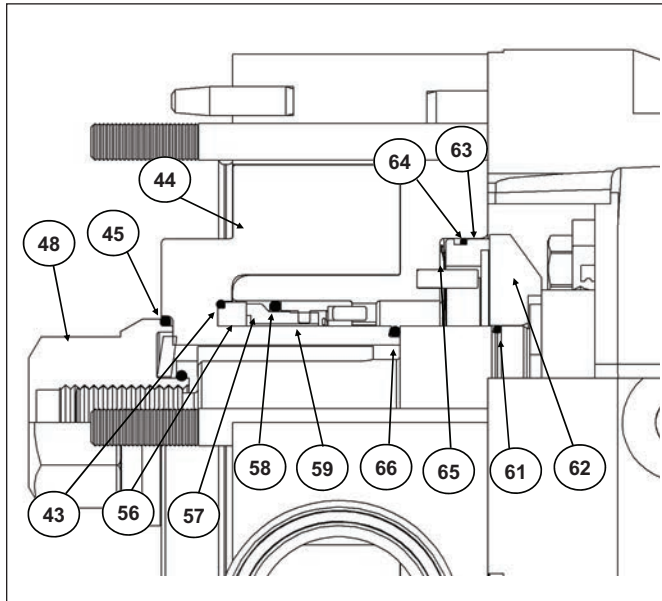

Figure 37. Installing Stationary Seals

**SEAL CUTAWAYS**



Item No.	Qty	Description
48	2	Rotor Nut
45	2	O-Ring, Rotor Nut
44	2	Rotor
43	2	O-Ring, Rotor Seal Face
56	2	Rotor Seal Face
57	2	Body Seal Face
58	2	O-Ring, Body Seal Face
59	2	Inner Wave Spring
66	2	O-Ring, Rotor Hub
65	2	Outer Seal Wave Spring
64	2	O-Ring, Outer Seal
63	2	Outer Seal
62	2	Seal Seat
61	2	Shaft O-Ring

Specific parts for Double Mechanical Seals (61-65)



### Gear Case Maintenance

**⚠Warning**

Shut off and lockout all power and relieve system pressure before servicing to prevent accidental start-up and injury.

**⚠Caution**

SHUT OFF product supply to the pump and drain the pump before disconnecting piping and disassembly.

**DISASSEMBLY**

1. Remove the pump head as described on page 21 (Pump Disassembly). Remove the bottom oil plug and drain the oil from the gear case (remove oil fill plug for faster drain). Remove the six hex head cap screws and washers from the gear case cover and slide the cover off the drive shaft (Figure 38). If the cover is stuck, use a soft mallet to tap around the edges until it breaks free. Using a straight edge remove the liquid gasket used to seal the cover to the gear case. Remove and discard the oil seal from the cover using an arbor press.

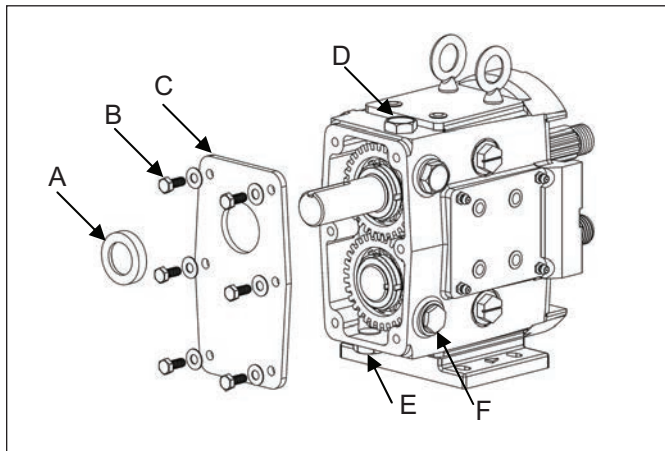

Figure 38. Gear Case Disassembly (Gear Case Cover)

Item No.	Part
A	Oil Seal
B	Cap Screws and Washers
C	Gear Case Cover
D	Oil Plug (Fill)
E	Oil Plug (Drain)
F	Sight Glass

2. Using a hammer and a punch, bend the tabs straight on the lock washers (Figure 39). Use a wedge (wood or plastic) to keep the shafts from turning while removing the lock nuts (Figure 40). Using a spanner wrench or the nut removal tool (available from Ampco), remove the gear lock nuts. Slowly remove the gears from the shafts. Remove the gear keys and gear spacers from the shafts.

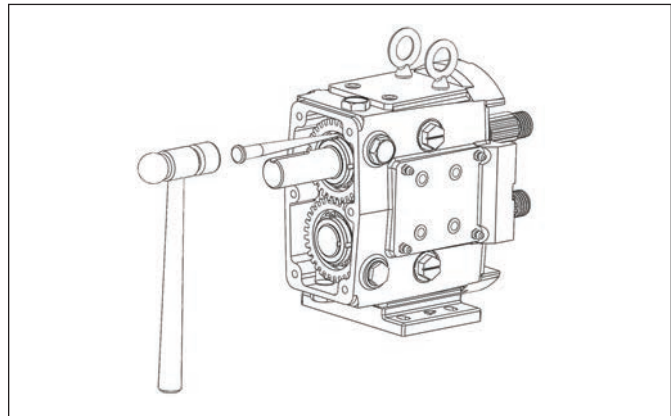

Figure 39. Bending Tabs on Lock Washers

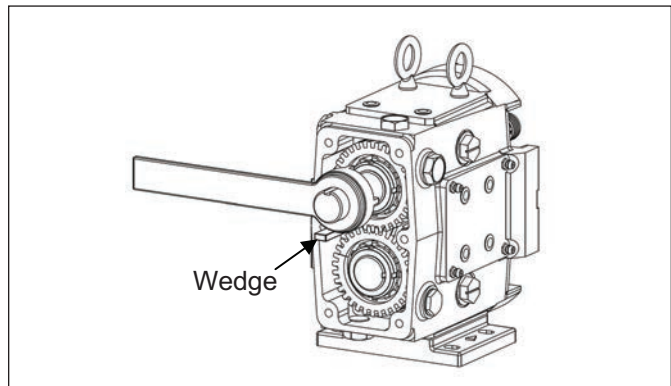

Figure 40. Removing Lock Washers

3. To prevent damage to the shafts, wrap the splines and rotor nut threads with tape (Figure 41, A). Any damage to the splines or threads may require the shaft be replaced. Remove the cap screws holding the bearing retainer and splash plates in place and slide both off the shaft (Figure 41, B). If they are stuck, use a flat head screw driver as a wedge to pry them from the gear case or leave them in place and when the shafts are removed they will press off with the shafts. Using a straight edge, remove the liquid gasket used to seal bearing retainer to the gear case.

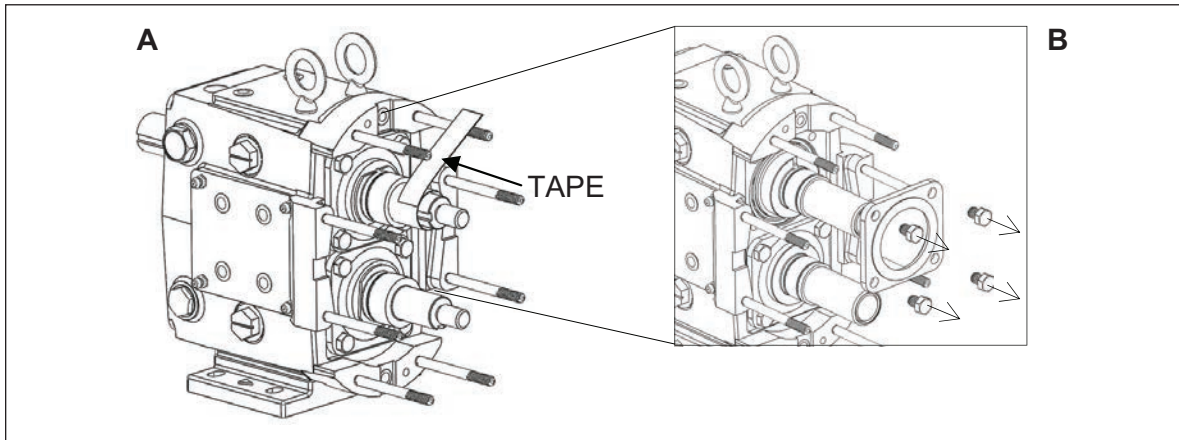

Figure 41. Tape Shafts and Remove Bearing Retainers

4. Set the gear case in a press with the fluid end side facing down (Figure 42). Use a wooden block to protect the shafts from hitting the ground when pushed out. Once the protective block is in place push the shafts out of the gear case. Reference Table 4 for the required force (in tons) needed to press the shafts out of the gear case.

Table 4. Required Force to Remove/Install shafts

ZP3 Model	6, 15, 18	30, 34, 40	45, 60, 64, 130, 134	180, 184, 220, 224	210, 214, 320, 324
In (Tons)	0.25	0.25	0.50	0.50	0.50
Out (Tons)	0.50	0.50	1.00	1.00	1.00

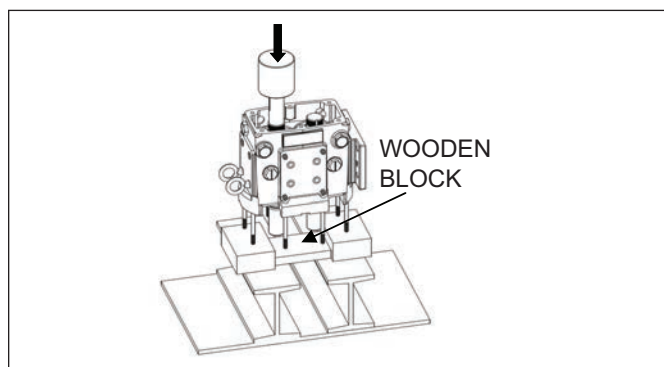

Figure 42. Pressing Shafts from Gear Case

5. Remove all the shaft shims from the gear case and label which shaft and bore they came from. If the shafts are to be reused, they will need to be reinstalled with the original shims. Failure to do so could result in damage and misalignment in the pump body. Remove and discard the rear oil seals from the back of the gear case. Use a long, non-metallic rod and a soft mallet to punch the seal out from the front side (Figure 43, A). Remove and discard the front bearing seals from the bearing retainers by pressing them out (Figure 43, B). Clean the bearing retainers as they will be reused. Clean excess grease and sludge inside of the gear case before reassembling.

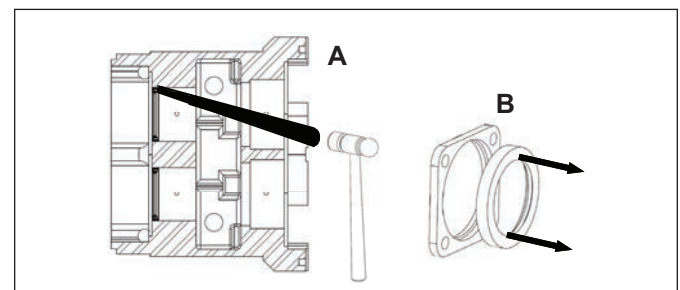

Figure 43. Removing Oil Seals

6. Using a press and a V-block, remove the front and rear bearings along with the bearing spacer. To prevent damage to the shafts make sure that both ends are protected (Figure 44). Reference Table 5 for the required force (in tons) needed to press the bearings off the shafts.

**Table 5. Force Required to Press Bearings**

ZP3 Model	Front Bearings		Rear Bearings	
	On (Tons)	Off (Tons)	On (Tons)	Off (Tons)
6, 15, 18	0.50	1.00	0.50	1.00
30, 34, 40	0.50	1.00	0.50	1.00
45, 60, 64, 130, 134	2.00	5.00	3.00	5.00
180, 184, 220, 224	5.00	15.00	5.00	15.00
210, 214, 320, 324	5.00	20.00	5.00	20.00

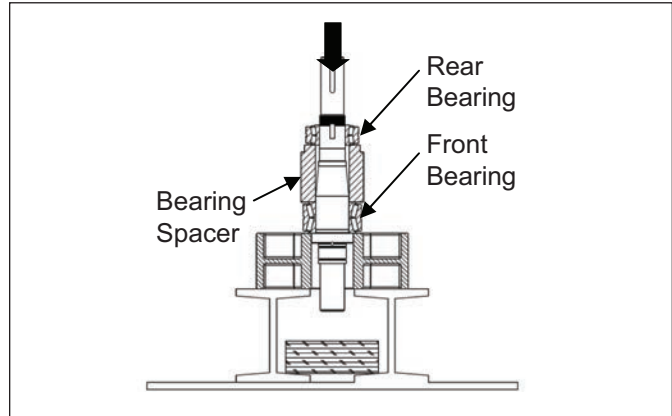

Figure 44. Removing Bearings and Sleeve from Shaft

**ASSEMBLY**

1. Clean all reusable parts prior to reassembly. Apply a light coat of lubricant on the shaft area where the front bearing will sit. Position the shaft upright in the press with the splines facing down (Figure 45, Drawing 1). Open the new front bearing assembly and be sure not to interchange any parts. All bearings are manufactured as sets and assembled to have a precise overall length. Place the front bearing over the shaft along with the bearing spacer

(Figure 45, Drawing 2). Make sure the bearing and spacer are aligned before pressing them on. Reference Table 5 for the required force (in tons) needed to press the bearings on to the shafts. Using a sleeve that rests on the bearing spacer and rides over the shaft, press the bearing on until it seats against the shaft shoulder. A shim can be used to ensure that the bearing is fully rested on the shaft shoulder (Figure 45, Drawing 3).

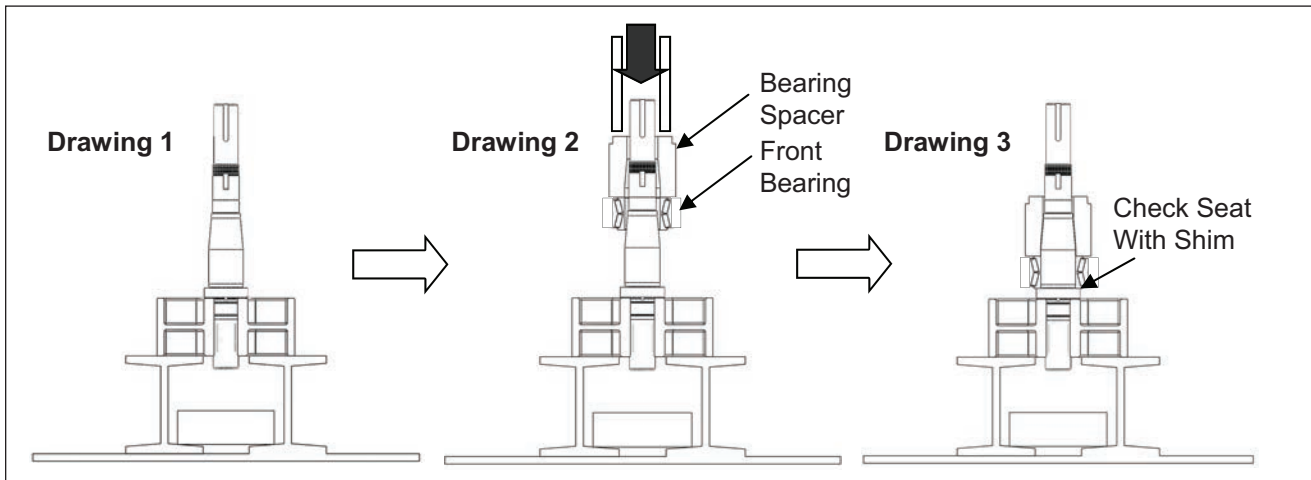

Figure 45. Pressing Front Bearing onto Shaft



2. Single ball bearings are used for the rear bearing in models ZP3 6, ZP3 15, ZP3 18, ZP3 30, and ZP3 34 and will require a light press to install. Tapered roller bearings are used for all other models and will be pressed on similar to the front bearings.
    - For pump models with single ball bearings apply a light coat of lubricant on the shaft. Open the new rear bearing assembly and place it over the shaft above the bearing spacer with the shielded side of the bearing facing the spacer (*Figure 46, Drawing 1*). Press the bearing on by pressing only on the inner race.
    - For pump models with tapered roller bearings, apply a light coat of lubricant on the shaft. Open the new rear bearing assembly and do not interchange any parts. Place the rear bearing over the shaft above the bearing spacer (*Figure 46, Drawing 2*). Reference Table 5 for the required force (in tons) needed to press the bearing onto the shaft. Using a sleeve that rests on the inner cone of the bearing and rides over the shaft, press the bearing on until it seats against the spacer.
- Make sure the bearing is rested on the bearing spacer using a shim (*Figure 46, Drawing 3*).

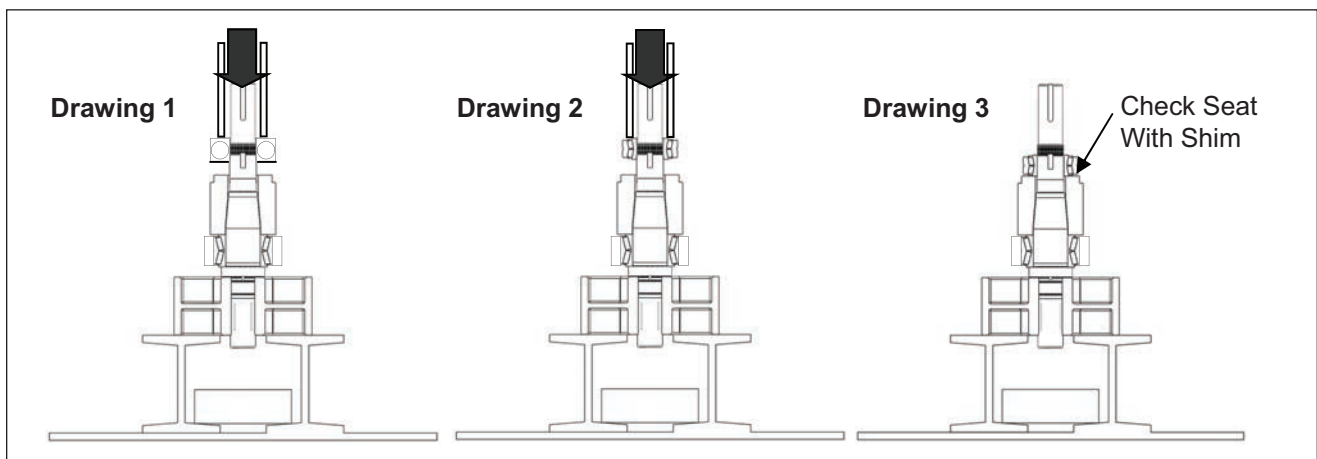

Figure 46. Pressing Rear Bearing onto Shaft

3. Shims located on the shaft behind the front bearing control the backface clearance of the pump; the space between the body and the rotor. If neither the shafts or bearings are being replaced, use the shims (if properly marked) removed at disassembly and reuse making sure they are installed in the correct bores. If replacing shafts or bearings, a process of calculating the required shims is necessary. Use *Figure 47* and the following equation to calculate. To find the correct backface clearance see *Table 10, page 41*.

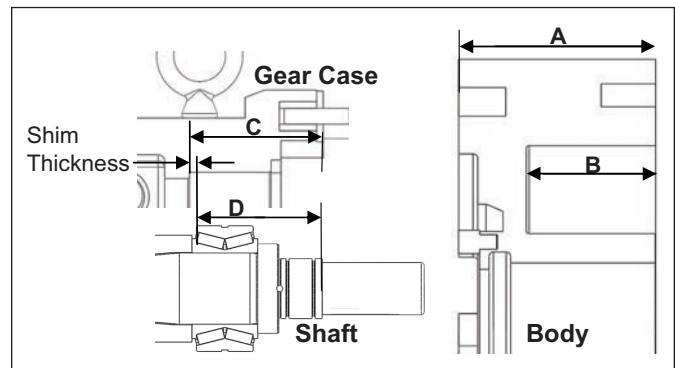

Figure 47. Calculating Shims

- Measure A, B, C, and D
- Find Correct Backface Clearance
- Backface Clearance+C+A-D-B = Shim Thickness
  - A. Body Width
  - B. Depth of Rotor Bore
  - C. Distance from gear case pads to bottom of front bearing pocket
  - D. Distance from shaft shoulder to back of bearing race

- Set the gear case on a press with the fluid end side facing up. Place the required thickness of shim stock so it sits on the shoulder of the front shaft bore of gear case. Apply lubricant to the outside of the bearings. Place shaft assembly (one shaft at

a time) in the gear case with the spline end facing up. Making sure that the drive and the short shafts are in the correct bores, press the shafts into gear case until bearings are fully seated (*Figure 48*). See *Table 4* on page 31 for the required force.

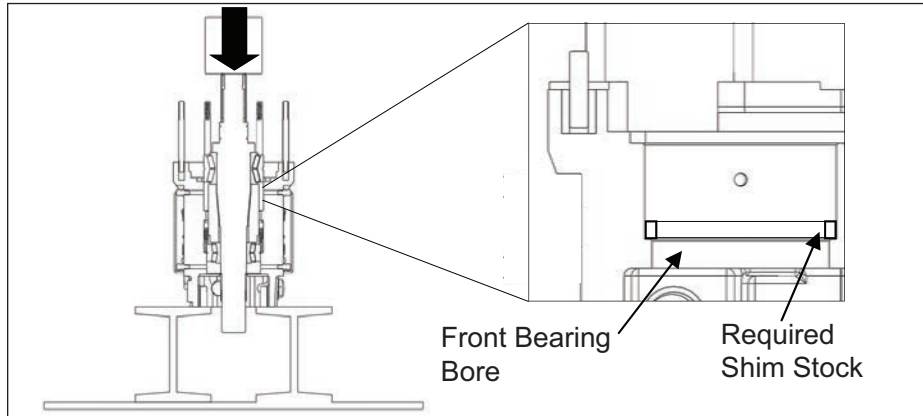

Figure 48. Pressing Shafts into Gear Case

- Once the shafts are pressed into the gear case, install the bearing retainers to hold the shafts in place temporarily (do not install liquid sealant). Ensure there is proper clearance between the retainer and the gear case, as seen in *Figure 49*. Place the body on the gear case, making sure it is seated correctly. Assemble the rotors into the body and tighten down using the jam nuts. Measure dimensions A, B, and C seen in *Figure 50* and refer to *Table 10* on page 41 to verify the clearances. If clearances are not correct, the shafts must be removed and the shims will need to be adjusted. If the clearances are correct, remove the rotors and body.

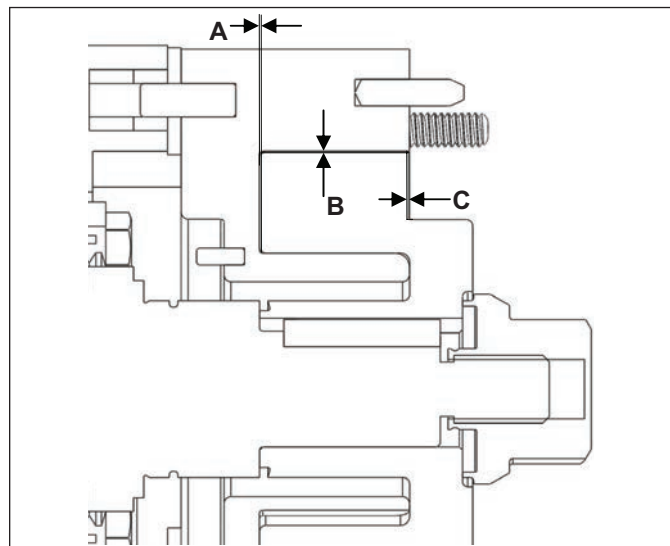

Figure 50. Important Clearances

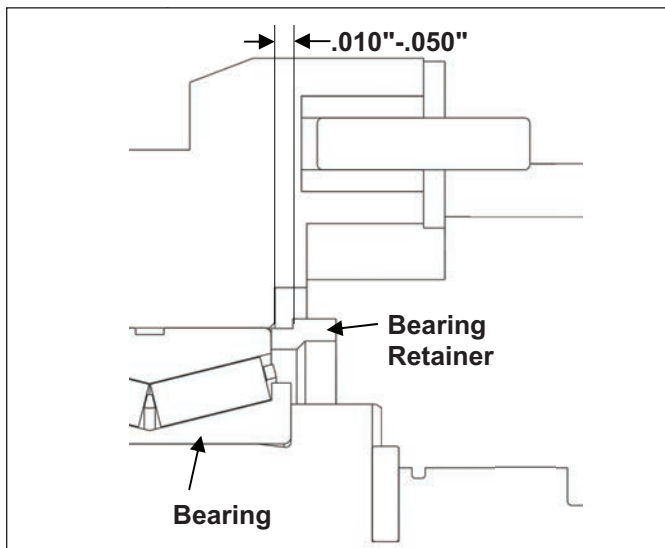

Figure 49. Bearing Retainer Clearance

- Once the correct backface clearance is achieved, fill all bearings with grease through the fittings on the mounting pads until grease is noticeable around the bearing assemblies. The shafts should be rotated during this initial greasing to distribute the grease evenly. Apply a light film of lubricant to the inside and outside diameters of the oil seals and install them into the bearing retainers. Apply silicone sealant to the outside flanges on the bearing retainer (*Figure 51*). Once the silicone sealant is applied, install the bearing retainers onto the gear case.

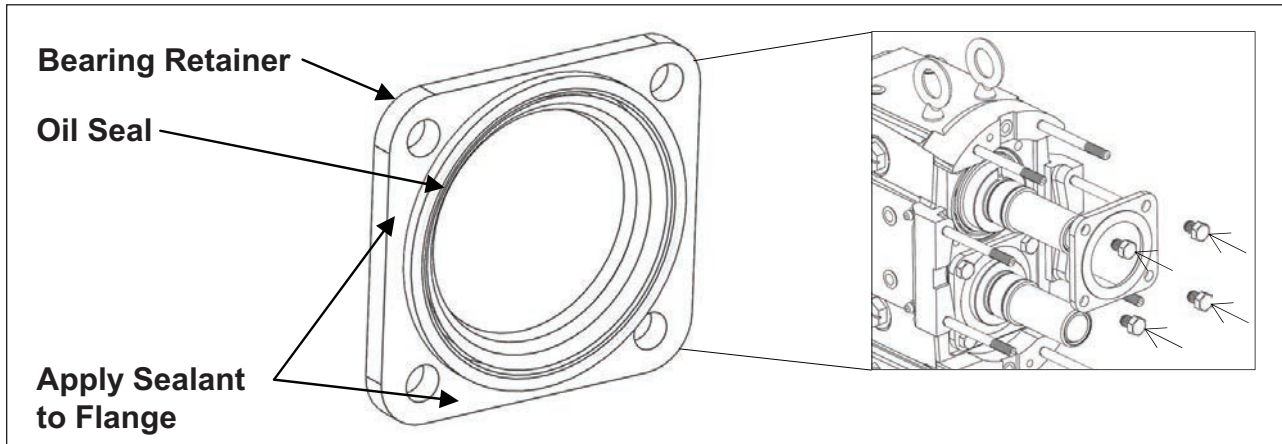

Figure 51. Bearing Retainer Installation

7. Apply a light film of lubricant to the inside and outside diameters of the rear oil seals and install them into the back of the gear case with the spring side facing outward toward the gear. Install the gear spacers onto the shaft and place the gear keys into the shaft key slots (Figure 52).

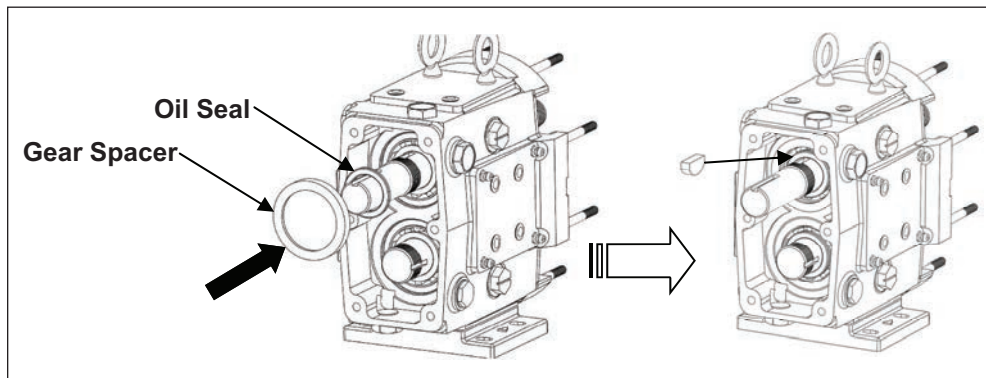

Figure 52. Rear Oil Seal and Gear Key Installation

8. Once the gear keys are installed, orientate the shafts so that the keyways on the drive shaft are pointing in the 12 o'clock direction (Figure 53, A). Slide the right-handed gear with the single punch mark onto the drive shaft. Slide the second gear with two punch marks on the short shaft. To time the gears, align so that the single punch mark falls between the two punch marks on the opposite gear (Figure 53, B).

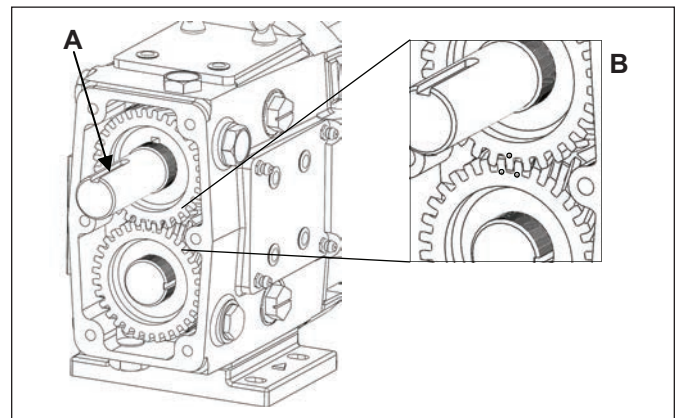

Figure 53. Installing Gears with Correct Timing

- Install the lock washers on the shaft by aligning the tab inside the lock washer with the slot in the shaft (Figure 54, A). Lubricate the threads of the lock nuts and thread them on the shafts. Using a spanner wrench, tighten them to the specified torque in Table 6. Use a wedge (wood or plastic) between the gear teeth to keep the shafts from turning while tightening the lock nuts (Figure 54, B).

Secure the nut in place by bending the locking tabs on the lock washer into the lock nut slots (Figure 55).

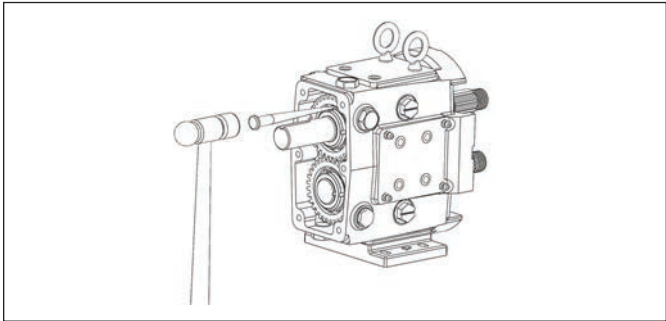

Figure 55. Bending Tabs on Lock Washer

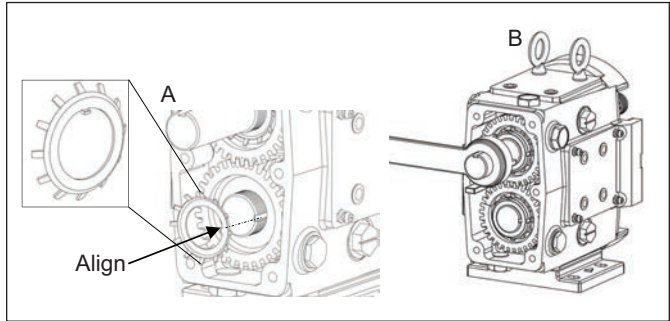

Figure 54. Installing Lock Washer and Lock Nut

Table 6. Recommended Lock Nut Torque Values

ZP3 Model	Torque	
	ft-lbs	N-m
6, 15, 18	75	102
30, 34, 40	100	136
45, 60, 64, 130, 134	140	190
180, 184, 220, 224	230	312
210, 214, 320, 324	320	434

- Apply a light film of lubricant to the inside and outside diameters of the gear case cover oil seal. Using a press, install the oil seal into the back cover so that it is flush with the outside of the back cover and the spring is facing the gears. Apply a silicone sealant to the edges on the back of the gear case making sure there are no gaps. Slide the back cover onto the gear case, making sure that the shaft is centered on the oil seal, and secure it with the retaining bolts (Figure 56). It is important not to cut the oil seal on the shaft keyway; tape may be used to cover any sharp edges on the shaft. Install the oil plugs and fill the gear case with the recommended amount of oil using Table 3 on page 18.

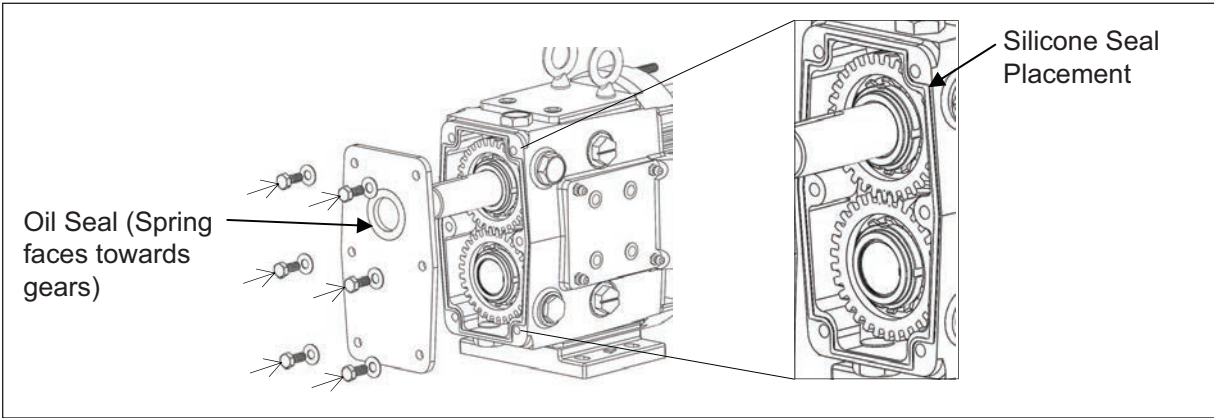

Figure 56. Installing Gear Casing Back Cover



## Pump Assembly

### ⚠ Caution

Handle the rotors, piping, and other pump components carefully as edges may be sharp. Wear gloves to avoid injuries.

### ⚠ Warning

The body must be re-assembled to existing sub-assembly from which it was removed. Reference serial numbers on the body and sub-assembly to verify the match. Failure to correctly re-assemble the pump could result in damage and severe injury.

1. Make sure all seal components are installed by following “Seal Maintenance” instructions provided on *page 24*. Ensure all dowels are in place and that all parts including body, rotors, and rotor nuts are clean and free of foreign matter. Slowly slide the body over the gear case studs and shafts, ensuring the seals are kept in place and not damaged (*Figure 57*). Install the two hold-down bolts and tighten the body against the gear case to ensure the dowels are engaged. Rotate the shafts to make sure there is no interference with the seals.

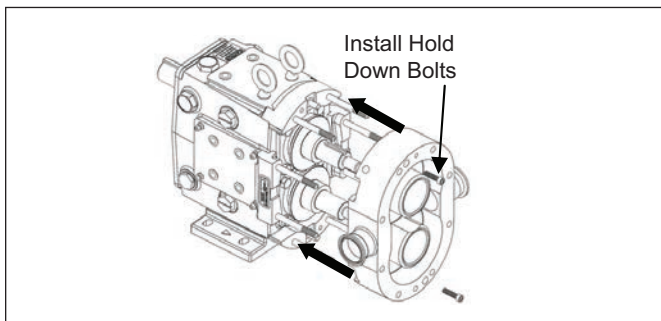

Figure 57. Installing Pump Body

2. Insert rotor key in the keyway on the shaft. Install a new rotor hub o-ring on the rotor hub and align the rotor keyway to the key in the shaft (*Figure 58*, A). Slide the rotor on until it seats against the shaft. Install the Bellville washer in the rotor nut and hold it in place using the small retaining o-ring (*Figure 58*, B). Place one nut on at a time, tightening them down using the appropriate wrench and a non-metallic wedge to hold the rotor in place (*Figure 58*, C). See *Table 7* for required torque values. Repeat with the second rotor.

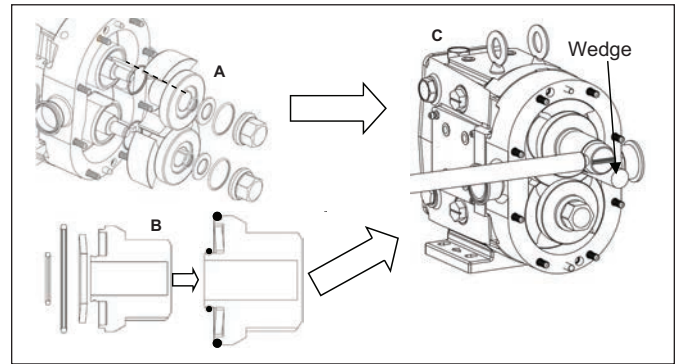

Figure 58. Installing and Securing the Rotor

Table 7. Recommended Rotor Nut Torque Values

ZP3 Model	Torque	
	ft-lbs	N-m
6, 15, 18	50	68
30, 34, 40	120	163
45, 60, 64, 130, 134	250	339
180, 184, 220, 224	325	441
210, 214, 320, 324	375	508

3. Install the new cover o-ring and slide the cover over the studs making sure that the dowels in the body are aligned with the correct dowel holes in the cover (*Figure 59*). Visually inspect to ensure that the cover o-ring remained in place. Turn the cover nuts (clockwise) by hand and fully tighten them by using the appropriate wrench. Tighten the rotor nuts in an opposing manner as seen in *Figure 59*, so that the cover is evenly tightened to the body.

Table 8. Cover Nut Torque Chart

Pump Model	Cover Nut Torque
006, 015, 018	7 ft-lb (10 N•m)
030, 040	11 ft-lb (15 N•m)
045, 060	56 ft-lb (76 N•m)
130	25 ft-lb (34 N•m)
180, 220	110 ft-lb (149 N•m)
210, 320	158 ft-lb (214 N•m)

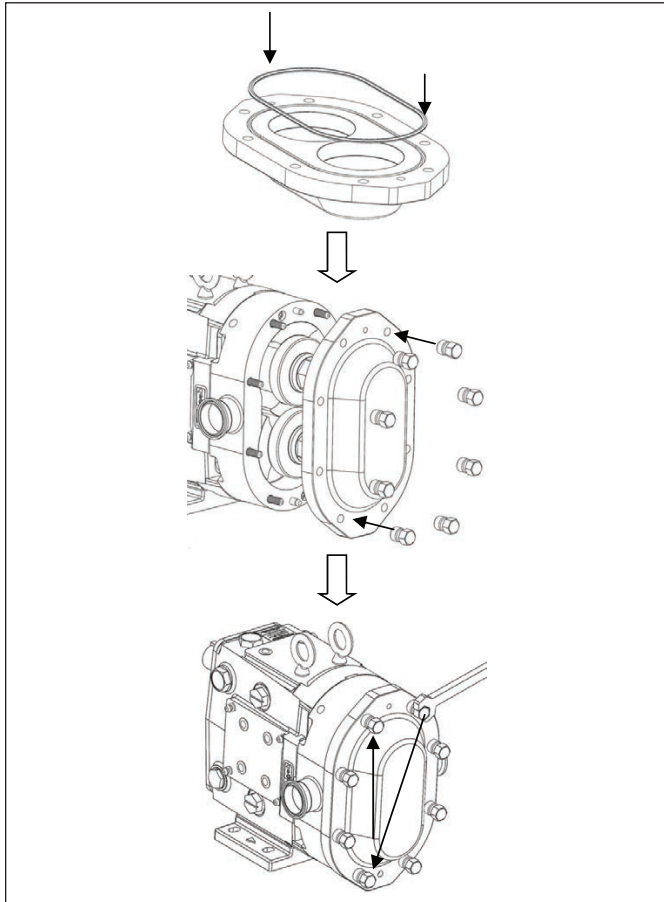

Figure 59. Installing Cover Assembly

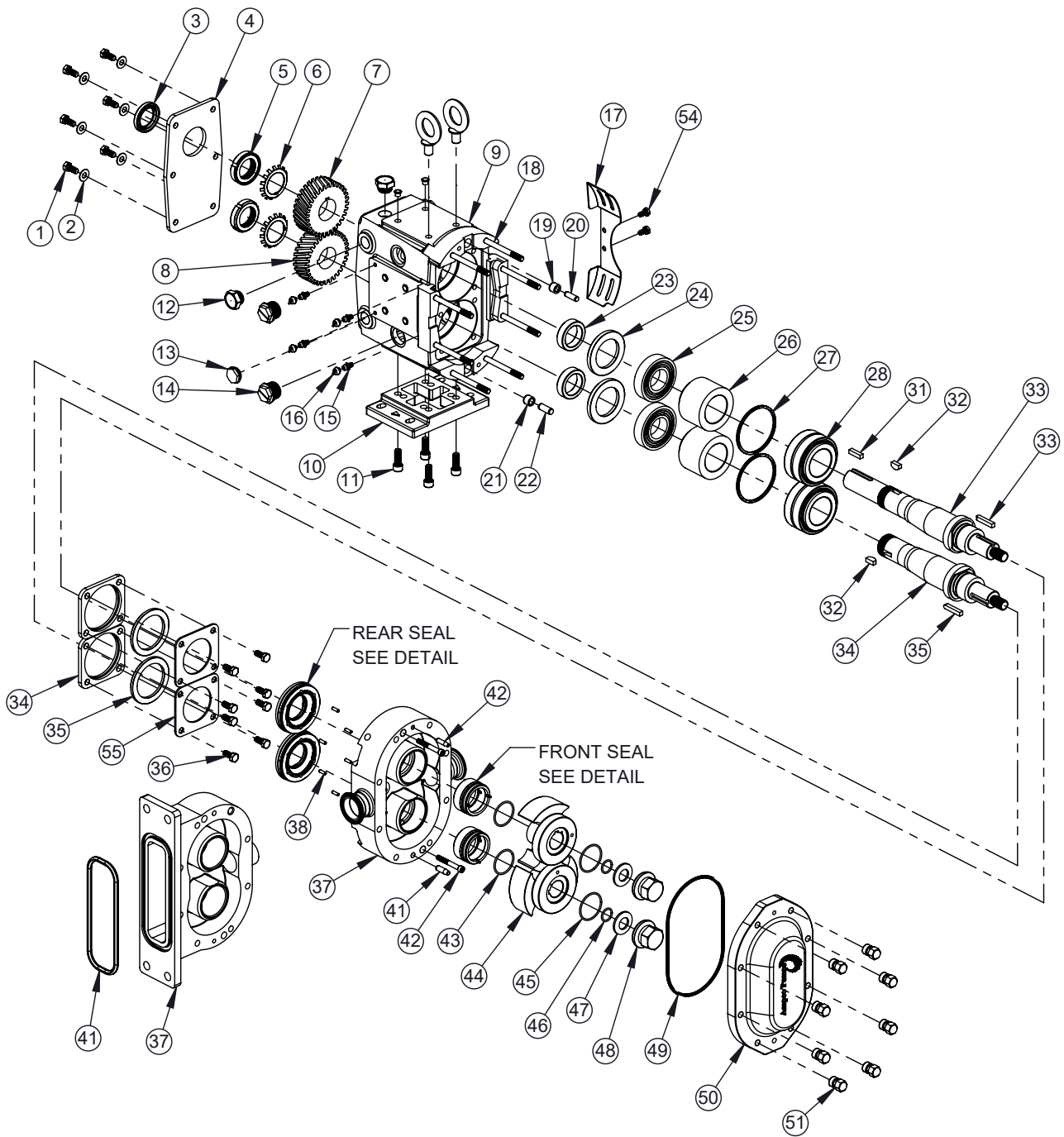

Table 9. ZP3 SERIES PARTS BREAKDOWN

Item No.	Qty	Description
1	6	Gear Case Cover Bolt
2	6	Gear Case Cover Washer
3	1	Gear Case Cover Oil Seal
4	1	Gear Case Cover
5	2	Gear Locknut
6	2	Gear Lock Washer
7	1	Gear, Driveshaft
8	1	Gear, Idle Shaft
9	1	Gear Case
10	1	Gear Case Base
11	4	Bolt, Gear Case Base
12	5	Plug, Oil Drain/Fill
13	1	Plug, Oil Level Sight
14	4	Plug, Cleanout
15	8	Grease Fitting
16	8	Grease Fitting Cover
17	2	Seal Guard
18	8	Stud
19	1	Dowel Bushing, Upper
20	1	Dowel Pin, Gear Case, Upper
21	1	Dowel Bushing, Lower
22	1	Dowel Pin, Gear Case, Lower
23	2	Spacer, Gear to Rear Bearing
24	2	Oil Seal, Rear
25	2	Bearing, Rear
26	2	Spacer, Bearing
27	2	Shim Kit
28	2	Bearing, Front
29	1	Driveshaft
30	1	Idle Shaft
31	1	Drive Key
32	2	Gear Key
33	2	Rotor Key
34	2	Bearing Retainer
35	2	Bearing Retainer Lip Seal
36	8	Bolt, Bearing Retainer
37	1	Body
38	2	Seal, Stop Pin
39	1	O-Ring, Rect. Flange Inlet
40	1	Dowel Pin, Cover Upper
41	1	Dowel Pin, Cover Lower

Item No.	Qty	Description
42	2	Body Retaining Screws
44	2	Rotor
45	2	O-Ring, Rotor Nut
46	2	O-Ring, Retainer
47	2	Belleville Washer
48	2	Rotor Nut
49	1	O-Ring, Cover
50	1	Cover
51	8	Cover Hex Nut
52	12	Plastic Cap Plug
53	2	Eye Bolt
54	4	Nail, Seal Guard
55	2	Splash Plates



### Pump Clearances

The performance of a ZP3 is based on the tight clearances between the pump body and the rotors. These clearances are critical to ensure the pump performs up to the system requirements. The clearance between the rotor and the back face of the body is referred to as the backface clearance. The backface

clearances are set when the gear case is assembled (page 33) using shims placed between the gear case and the front bearing. Other clearances are shown in Figure 60 and should be in accordance to Table 10. Use shims and a depth micrometer to measure the clearances.

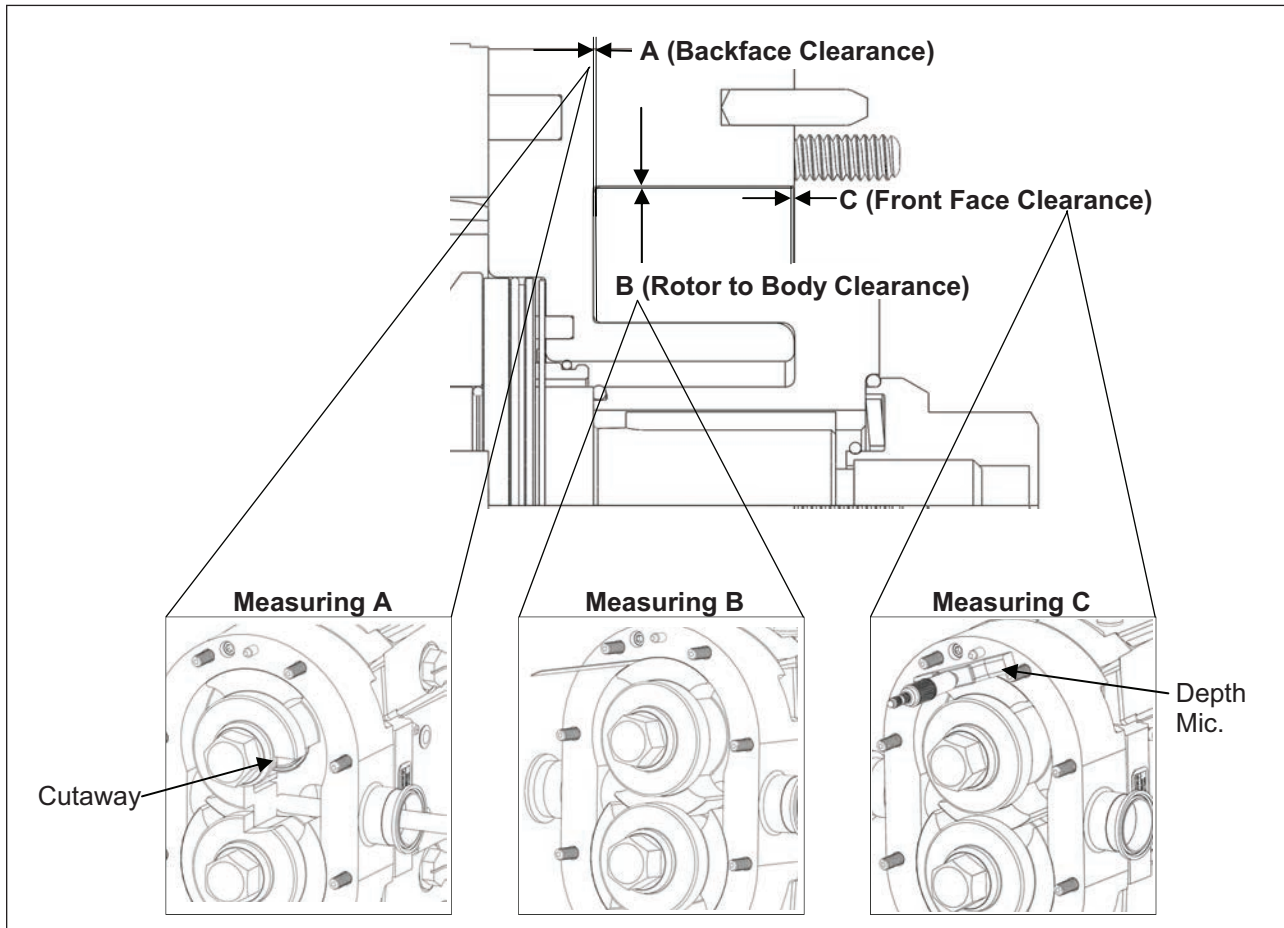

Figure 60. Critical Pump Clearances

Table 10. Critical Pump Clearance Dimensions

ZP3 Model	A (Backface Clearance)		B (Rotor to Body Clearance)		C (Front Face Clearance)	
	Inch	mm	Inch	mm	Inch	mm
6, 15, 18	0.002	0.05	0.002	0.05	0.005	0.13
30, 34, 40	0.002	0.05	0.002	0.05	0.005	0.13
45, 60, 64,	0.004	0.10	0.005	0.13	0.008	0.20
130, 134	0.004	0.10	0.005	0.13	0.008	0.20
180, 184, 220, 224	0.005	0.13	0.006	0.15	0.008	0.20
210, 214, 320, 324	0.005	0.13	0.010	0.25	0.011	0.28

### Ampco Pumps Available Options

#### VENTED COVER (PRESSURE RELIEF)

The vented cover option is an internal pressure and flow control which works independent of flow (rotational direction). The complete assembly can be seen in *Figure 61*. The relief pressure is set with the adjustment screw and may require in-line pressure gauges for calibration. The vented cover is designed for COP (Clean-Out-of-Place) practices.

**Notice**  
Ampco Pumps does not recommend using a vented cover on liquids over 5000Cp.

Item No.	Qty	Description
64	1	Vented Cover
65	1	Rubber Diaphragm
66	1	Diaphragm Bushing
67	1	Spring Plunger
68	1	Spring
69	1	Cover Nut
70	1	Lock Nut
71	1	Adjusting Screw

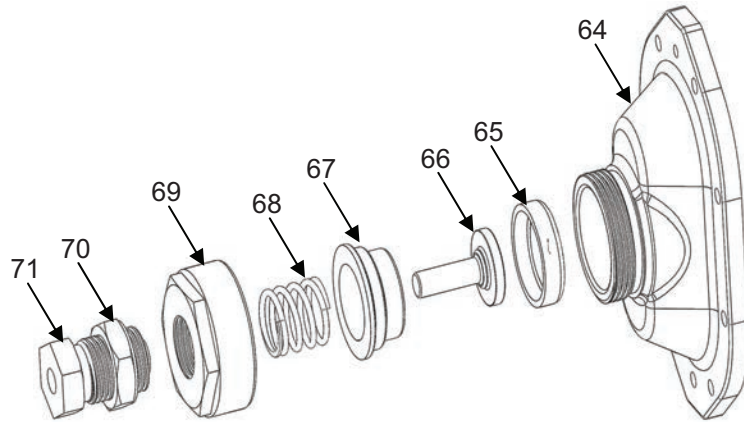

Figure 61. Vented Cover

#### JACKETED COVER

The jacketed cover option (*Figure 62*) allows for heating or cooling fluid to be circulated through to match the demands of certain products. This fluid (media) can preheat or cool the fluid end and sustain the product temperature during operation and short shutdowns.

The jacketed cover is not a heat exchanger and is not designed to primarily control the product temperature. This option requires longer gear case mounting studs. Please contact Ampco for replacement information. The pressure limit for the jacketed cover is 60 psi.

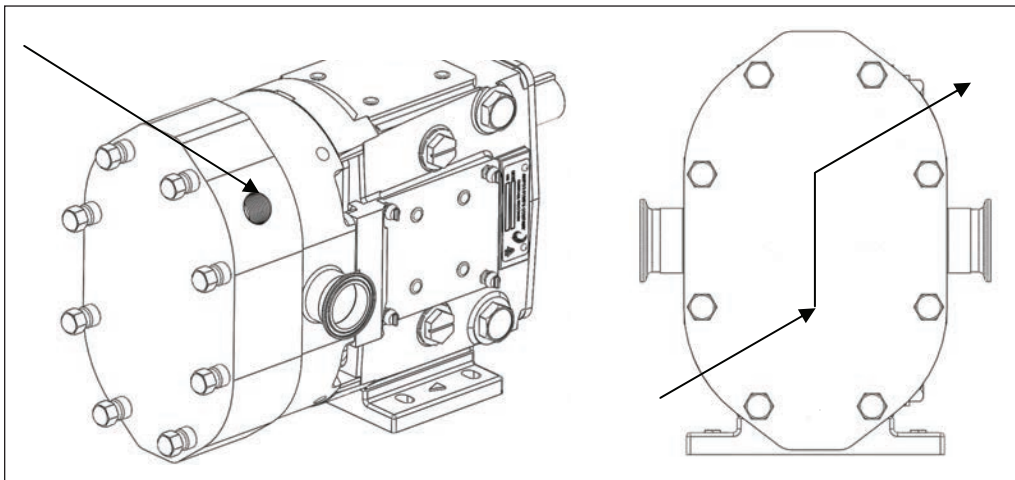

Figure 62. Jacketed Cover

ZP3 Pump Model	Thread Size
6, 15, 18, 30, 40	3/4" NPT

ZP3 Pump Model	Thread Size
45, 60, 130, 180, 220	1" NPT

## Section 5 Troubleshooting

### Troubleshooting

Each Ampco ZP3 is assembled and tested at the factory and is designed to have trouble-free operation. Problems may occur over the life of the pump due to system variations, standard wear, or user error. The following table has information that may help identify and solve a problem. For additional technical assistance, please contact Ampco with the pump's serial number.

Symptom	Cause	Solution
<b>NO FLOW (rotors are not turning)</b>	Drive motor is not running or connected	Check connection and power source to pump motor drive
	Keys (gear, drive shaft) are sheared or missing	Check or replace
	The pump's drive (gearbox, belts, transmission) is broken or slipping	Check, replace, or adjust
	Pump shafts or gears are broken	Check and replace, if necessary
<b>NO FLOW (rotors are turning)</b>	Rotors are turning in the wrong direction	Check motor connections for correct hookup (see "Pump Rotation" on page 13)
	Discharge port/valve is closed or blocked	Check and open, if necessary
	Inlet port/valve is closed or blocked	Check and open, if necessary
	Pump relief valve (optional) is not set correctly, or is held open by foreign matter	Check and clean, if necessary. Check system so that unwanted debris doesn't enter pump
<b>NO FLOW (pump is not priming)</b>	Inlet valve closed	Open valve, if necessary
	Inlet line restricted or clogged	Clean lines and check system
	Too much air in the inlet line	Check lines for leaks, replace gaskets or pipes, if needed
	The pump's speed is too low	Increase speed of pump
	The pump's speed is too high	Check viscosity of product, and reduce speed as needed
	No product in the inlet lines (lines drain or siphon when pump is off)	Foot valves or check valves may be used. Having product in the line is necessary for the pump to prime
	Pump is air locked	Install air bleeds to the pump and lines
	Pump may be worn out	Increase the pumps speed or replace worn out rotors
	Inlet pressures too low	Check pressure required. Change, if necessary
	Differential pressure differences not developing	Install check valves on discharge to prevent large back pressures
<b>Inadequate Flow</b>	Speed is too low or too high	Check published pump curve and adjust speed, if necessary
	Air leaks in inlet line	Check for bad seals, bad gaskets and piping connections
<b>Inadequate Flow and Flow Is Bypassing Pump</b>	Open valve (inlet drain, trap valve)	Check valves and close, if needed
	Relief valve not adjusted correctly or stuck	Check relief valve and adjust, if necessary
<b>Inadequate Flow, Pump Is Noisy During Operation (slipping)</b>	Non-standard rotors (Hot clearance, Hot Chocolate clearance, Stainless) are being used on low viscous fluids	Use appropriate rotors for product (contact Ampco for additional support, if needed)
	Body and rotors are worn	Increase speeds, replace rotors, or have the pump remanufactured (page 41)
	Pressures are too high for pump	Adjust system

Symptom	Cause	Solution
<b>Starved Pump Inlet (fluid vaporization)</b>	Strainers, valves (inlet side), fittings, or lines are plugged or restricted	Check and clean lines/valves
	The Inlet line is too small (inside diameter) or long, or both	Increase inlet pipe size and/or decrease pipe length
	Too many valves or fittings	Reduce number of fittings or valves
	Valves or strainers are too small	Check and change, if necessary
	The net inlet pressure is too low	Check pump and system requirements and change system or pump, if necessary
	Product viscosity greater than expected	Change system parameters (temperature, flow, pressure)
	Product temperature is higher than expected	Reduce speed, temperature and flow, if necessary
<b>Excessive Power Is Required (pump overheats, stalls, draws high current, fuses/ breakers are tripping)</b>	Viscosity losses higher than expected	Increase pump speed, if needed
	Pressures higher than expected	Decrease pump speeds and modify inlet line sizes
	Viscosity is higher than expected	Heat product, or change system parameters
	Viscous product sits in line during shutdown	Install a soft start on motor drive, clean lines or change system to avoid problem
<b>Noisy Operation (cavitation)</b>	Product's viscosity, vapor pressure and temperature are too high	Check system setup. Change speeds and temperatures, accordingly
	The inlet pressure available is less than required	Check inlet pressure requirements and adjust accordingly
<b>Noisy Operation (air or gas in fluid)</b>	Air leaks in the system	Check for leaks and correct, if needed
	Product emits gases	Install pressure relief valves
<b>Noisy Operation (rotor to body contact)</b>	Assembly without checking fluid end clearances	Check pump clearances and adjust, if necessary ( <i>page 37</i> )
	Internal stresses in pump caused by improper piping support	Adjust system to eliminate stresses ( <i>page 10</i> )
	Pressures are higher than what the pump is rated for	Reduce pressures
	Bearings are worn	Check for bearing movement ( <i>page 19</i> ) and replace, if necessary
<b>Noisy Operation (rotor to rotor contact)</b>	Gears are loose or incorrectly timed (damage to rotor may be severe )	Rebuild pump with new parts
	Keys are sheared	Inspect and rebuild, if necessary
	Gears are worn	Inspect and replace gears, if needed. Inspect damage to rotors and rebuild, if necessary
<b>Noisy Operation (external mechanical problems)</b>	Gear drive, drive belts, coupling or bearings are worn or not correctly adjusted	Check and replace. Adjust, if needed
<b>Short Pump Life</b>	Product is abrasive	Check system, and possibly implement a larger pump at lower speeds
	Pump speeds and pressures are higher than pump rating	Check system and change, if necessary. Reduce speeds and pressure of pump
	Improper gear case lubrication	Check and replace worn out gears and bearings; follow procedures on <i>page 17</i> for proper lubrication
	Water build up in gear case	Check that all gear case plugs are in place
	Misalignment in system (piping or pump drive)	Check and modify system to eliminate alignment issues

## Section 6

### Appendix

---

#### PD Pump Remanufacturing Program

With the purchase of each new ZP pump, Ampco guarantees two full remanufactures. Depending on wear, the ZP pumps (and equivalents) can be remanufactured up to four times. This process returns a used pump to new pump performance and appearance. Each fully remanufactured pump includes a one year warranty. The following upgrades are included when remanufacturing a competitor's pump: 17-4 shafts, stainless steel bearing retainers, helical gears, and sealed clean out plugs. These upgrades are standard to Ampco positive displacement new and remanufactured pumps.

Contact your local distributor or the factory (414) 643-1852 for more information.

#### ATEX Certification Information

1. Ampco pumps DOC (declaration of conformity) must be included with the pump. The declarations starting on *page 46* are provided for example purposes only. Please see the certificate you received with your pump.
2. ATEX certified pumps will be sent with black plugs on all drain and level ports at the rear of the gear case.
3. ATEX approval becomes void if non-Ampco replacement parts are used in the pump.

For additional support regarding ATEX certification, please contact the Engineering Department at Ampco Pumps Company, (414) 643-1852.

(1) **REGISTRATION CERTIFICATE**

(2) Equipment and Protective Systems intended for Use in Potentially Explosive Atmospheres – Directive 94/9/EC

(3) **Registration Number:**

**TUVNA 12 ATEX 7223  
File No. 31271925.001**

(4) **Documentation:** Technical Construction File (TCF) dated May 12, 2012(5) **Equipment:** ZP1, ZP2, ZP3, and AL Series Mechanical Pumps(6) **Manufacturer:** Ampco Pumps Company(7) **Address:** 2045 West Mill Road  
Glendale, WI 53209

(8) The aforementioned technical construction file has been received by TUV Rheinland of North America and has been registered under Registration No. TUVNA 12 ATEX 7223, File No. 31271925.001 on behalf of our sister organization TÜV Rheinland Industrie Service GmbH, a Notified Body with ref-no NB 0035.

(9) This equipment and any acceptable variations thereto are specified in the aforementioned technical construction file.

(10) With respect to the ATEX Directive (94/9/EC), the manufacturer has declared compliance with the following standards.

**EN 1127-1: 2007****EN 13463-1: 2009****EN 13463-5: 2003**

(11) The marking of the equipment shall include the following:

**II 2 G Ex c IIB T4**

(12) Other requirements as may be applicable are not covered by this Registration Certificate.

---

 Jim Dolphin

2012-09-10

---

 This Registration Certificate may only be reproduced in its entirety and without change.



## Conformance Certificate for Material Shipped

Customer ID CUMM10  
 Customer CUMMINS-WAGNER CO  
 Date Signed 12/7/2020  
 Customer PO No. POPA03399  
 Ampco Order No. 57837  
 Date Ordered 10/29/2020

Ampco Pumps Co. certifies that all items; including this report and the results of tests and values listed hereon are in full conformance with all purchase order and specification requirements. Further, the values shown represent the actual values obtained during testing, using the sample selection and test methods specified in the applicable material specification. It is also understood that knowingly and willfully falsifying or concealing a material fact on this form, or making false, fictitious or fraudulent statements or representations herein could constitute a felony punishable under Federal Statutes. All material supplied is also free from mercury alpha or radium contamination and are animal derived ingredient free. NO PRODUCTS CURRENTLY MANUFACTURED BY AMPCO PUMPS COMPANY ARE MADE FROM ASBESTOS OR ASBESTOS-CONTAINING COMPONENTS. THIS APPLIES TO ALL PARTS INCLUDING SEALANTS, GASKETS AND SEAL COMPONENTS.

<u>Line No.</u>	<u>Item Number</u>	<u>Description</u>	<u>Qty</u>
5	ZP3-060	PUMP, ZP3-60, MECH SEAL  <u>Line Notes</u> QN201671-2  <u>Specification</u> SS Gearcase w/CE Guards Bi-Wing Front Face Std Rotors Single Seal Viton Class 6 Elastomers Mech Seals - TC/SC Standard Body 2.5" Triclamp Bottom Drive Standard Cover Viton CL6 Cover O Ring 20Ra Finish Base, Coupling & Guard Gear Reducer & Motor GEAR REDUCER:GR0000551: NORD,6.31,SK32,FLG,210TC,INL MOTOR:GM5G14356: 7.5, 213TC, SS, WD, 1750, 3, 60, 230-460, PREM EFF Cover Drain PER DRAWING # 48-1-1672 Speedy Sleeve	1
10	MISC-MTR	MATERIAL TEST REPORT	1
15	MISC-SURFACE FINISH	SURFACE FINISH MAP	1
20	MISC-CERT OF CONFOR	CERTIFICATE OF CONFORMANCE	1
25	MISC-CERTIFIED DRAWI	CERTIFIED PUMP DRAWING	1
30	MISC-CERT PERFORMA	CERTIFIED PERFORMANCE CURVE	1
35	MISC-FEE	WELD LOG	1
APC			1/2

## Conformance Certificate for Material Shipped

Customer ID CUMM10  
 Customer CUMMINS-WAGNER CO  
 Date Signed 12/7/2020  
 Customer PO No. POPA03399  
 Ampco Order No. 57837  
 Date Ordered 10/29/2020

Ampco Pumps Co. certifies that all items, including this report and the results of tests and values listed hereon are in full conformance with all purchase order and specification requirements. Further, the values shown represent the actual values obtained during testing, using the sample selection and test methods specified in the applicable material specification. It is also understood that knowingly and willfully falsifying or concealing a material fact on this form, or making false, fictitious or fraudulent statements or representations herein could constitute a felony punishable under Federal Statutes. All material supplied is also free from mercury alpha or radium contamination and are animal derived ingredient free. NO PRODUCTS CURRENTLY MANUFACTURED BY AMPCO PUMPS COMPANY ARE MADE FROM ASBESTOS OR ASBESTOS-CONTAINING COMPONENTS. THIS APPLIES TO ALL PARTS INCLUDING SEALANTS, GASKETS AND SEAL COMPONENTS.

<u>Line No.</u>	<u>Item Number</u>	<u>Description</u>	<u>Qty</u>
40	MISC-HYDROSTATIC TE	HYDROSTATIC TEST	1

Issued by Ampco Pumps Company Inc.  
 Glendale, WI

  
 Authorized Representative

---

## Terms and Conditions

### AMPCO PUMPS Made of SELECTED corrosion-resistant alloys TERMS AND CONDITIONS OF SALE

1. **ENTIRE AGREEMENT.** This document contains all of the terms and conditions of the agreement ("the agreement") between Ampco Pumps Company, Inc. ("Seller") and the purchaser ("Purchaser") of the Products ("Products") to be sold to Purchaser, to the exclusion of any other statements and agreements, and to the exclusion of any terms and conditions incorporated in Purchaser's order or other documents of Purchaser. Seller's acceptance of Purchaser's order is expressly conditioned on Purchaser's acceptance of the terms and conditions contained herein, and Purchaser, upon placing an order, is presumed to have accepted all the terms and conditions without modification. No alteration, waiver, modification of or addition to the terms and conditions herein shall be binding on Seller unless set forth in writing and specifically agreed to by an officer of Seller. No course of dealing, usage of trade or course of performance will be relevant to supplement or explain any terms used in the agreement. All offers to purchase, quotations and contracts of sale are subject to final acceptance by Seller at its home office at Milwaukee, Wisconsin.
2. **PRICES.** Prices for Products manufactured by Seller pursuant to written accepted orders will remain firm for thirty (30) days from the date of any subsequent price change.
3. **TERMS OF PAYMENT.** Standard terms are ½% 10 days, 30 days net, from date of invoice unless otherwise stated. If, in the judgment of Seller, the financial condition of Purchaser at any time does not justify continuance of production or shipment on the terms of payment specified, Seller may require full or partial payment in advance. In cases of delays in payment, Seller reserves the right to charge interest on delinquent balances at the rate of 1 ½% per month.
4. **DELIVERY.** Except as otherwise provided expressly stated in the agreement, Products are sold F.O.B. Milwaukee. Seller will use reasonable commercial efforts to fill orders within the time stated, but the stated delivery date is approximate only, and Seller reserves the right to readjust shipment schedules without liability. Acceptance by Purchaser of the Products waives any claim for loss or damage resulting from a delay, regardless of the cause of the delay. Except as otherwise provided herein, Seller will not be responsible for freight, transportation, insurance, shipping, storage, handling, demurrage or similar charges. Claims by Purchaser for shortages in the Products must be made to Seller in writing within ten (10) days after date of receipt of the Products. No such shortage shall entitle Purchaser to withhold payment for Products which were received by Purchaser. Each such claim shall set forth in detail the basis and amount of such claim.
5. **TAXES AND FEES.** Seller shall pay all present and future sales, excise, privilege, use or other taxes, customs duties, and all other fees or other costs, imposed by any federal, state, foreign, or local authorities arising from the sale, purchase, transportation, delivery, storage, use or consumption of the Products or will, if applicable, provide Seller with an appropriate exemption certificate. Seller shall be under no obligation to contest the validity of any such taxes or to prosecute any claims for refunds or returns.
6. **INSTALLATION.** The Products shall be installed by and at the expense of Purchaser.
7. **LOSS, DAMAGE OR DELAY.** Seller will not be liable for loss, damage or delay resulting from causes beyond its reasonable control, including, without limitation, strikes or labor difficulties, lockouts, acts or omissions of any governmental authority or Seller, insurrection or riot, war, fires, floods, Acts of God, breakdown of essential machinery, accidents, embargoes, cargo or material shortages, delays in transportation, lack of production capacity or inability to obtain labor, materials or parts from usual sources. In the event of any such delay, performance will be postponed by such length of time as may be reasonably necessary to compensate for the delay. In the event performance by Seller under the agreement cannot be accomplished by Seller due to any of the foregoing causes within a reasonable period of time, Seller may, at its option, terminate the agreement without liability.
8. **RETURNS.** No Products or parts may be returned by Purchaser without the prior written consent of Seller.
9. **WARRANTY.** Seller warrants that the Products manufactured by Seller will be free from defects, material and workmanship under normal use and service for a period of one (1) year from date of shipment. In addition, the specified rating of each pump is warranted; however, the characteristic shape of the performance curves may vary from the published standards, and the capacity, head and efficiency guarantees are based on actual shop tests using clear cold water, and therefore the rating is specified in equivalent units of clear cold water. The sole obligation of Seller and the exclusive remedy of Purchaser for breach of this warranty shall be the repair (at Seller's facility) or replacement by Seller (F.O.B. Milwaukee, Wisconsin), at Seller's option, of any parts found to be defective, without charge and shall be conditioned upon Seller receiving written notice of any alleged breach of this warranty within a reasonable time after discovery of the defects, but in no event later than the end of the warranty period. The parts alleged to be defective shall be returned to Seller upon its request, freight prepaid. This warranty does not cover ordinary wear and tear, abuse, misuse, overloading, alteration or Products or parts which have not been installed, operated or maintained in accordance with Seller's written instructions. Seller shall not be liable for any expenses for repairs, additions or modifications to the Products outside of Seller's factory without its prior written consent, and any such repairs without such consent shall void this warranty. THIS WARRANTY IS EXCLUSIVE AND IS IN LIEU OF ALL OTHER EXPRESS AND IMPLIED WARRANTIES WHATSOEVER, INCLUDING BUT NOT LIMITED TO IMPLIED WARRANTIES OF MERCHANTABILITY AND FITNESS FOR A PARTICULAR PURPOSE. Seller may from time to time provide its facilities, personnel and experience to assist customers in the selection of materials, design, installation and operation of Products for maximum resistance to corrosion and abrasion with due consideration to the economy of the installation. This service is provided in an advisory capacity only and the final selection and operation of the Products and ancillary equipment shall be the sole responsibility of Purchaser or any user thereof. Accessories and parts manufactured by third parties are warranted only to the extent of such third party's warranty. IN NO EVENT SHALL SELLER BE LIABLE UNDER ANY CIRCUMSTANCES FOR ANY INCIDENTAL, CONSEQUENTIAL OR SPECIAL DAMAGES (INCLUDING, WITHOUT LIMITATION, ANY LOST PROFITS OR LABOR COSTS) ARISING FROM THE BREACH OF THIS WARRANTY OR OTHERWISE ARISING FROM OR RELATING TO THE PRODUCTS OR THEIR SALE, USE OR INSTALLATION.

- 
10. **CHANGES.** Changes in any work to be performed hereunder may be made only upon Purchaser's written instructions and acceptance by Seller in its discretion. Any change in drawings, materials or design of the Products, or to tools, fixtures or other items used to produce the Products, which affects Seller's cost to produce the Products will entitle Seller to adjust the price to take into account any additional costs. If work has been started, Seller shall be properly reimbursed for work already performed; if Products already produced are not accepted by Purchaser, Seller has the right to adjust the price to take into account any additional costs caused by an increase or decrease in quantities or in the time required for performance under the agreement.
11. **TERMINATION.** After Seller has commenced work, ordered any materials or made any other commitments pursuant to the agreement, it may be terminated only with the prior written agreement of Seller providing for equitable cancellation charges. Such charges shall reimburse Seller for any completed items at the contract price, and for any work-in-process items at the contract price less the cost to complete. Termination on any other basis must be specifically agreed on in writing in advance between Purchaser and Seller.
12. **DEFERRED DELIVERIES.** Orders or deliveries will be deferred only upon the prior written agreement of Seller in its discretion, and then only upon the following conditions:
- (a) The deferral period may not exceed sixty (60) days. At the end of the deferral period, if no release is provided by Purchaser, Seller reserves the right to render an invoice for and ship the completed portion of the order to the destination specified in Purchaser's order, or to store such material at Purchaser's expense at Seller's standard storage charges then in effect.
  - (b) For the portion of the order that is not completed, if no release is provided by Purchaser at the expiration of the deferral period, Seller reserves the right to render an invoice for any completed items at the contract price, and for any work-in-process items at the contract price less the cost to complete.
  - (c) Purchaser shall bear the risk of loss or damage to materials held at Purchaser's request.
13. **LIMITATION OF LIABILITY.** IN NO EVENT SHALL SELLER BE LIABLE UNDER ANY CIRCUMSTANCES: (a) FOR ANY INCIDENTAL, CONSEQUENTIAL OR SPECIAL DAMAGES (INCLUDING, WITHOUT LIMITATION, ANY LOST PROFITS OR LABOR COSTS) ARISING FROM OR RELATING TO THE PRODUCTS OR THEIR SALE, USE OR INSTALLATION; (b) FOR DAMAGES TO PROPERTY (OTHER THAN THE PRODUCTS PURCHASED FROM SELLER); (c) FROM ANY BREACH OF ITS WARRANTY OR ANY OTHER OBLIGATIONS TO BUYER; OR (d) FOR ANY OTHER CAUSE WHATSOEVER, WHETHER BASED ON WARRANTY (EXPRESSED OR IMPLIED) OR OTHERWISE BASED ON CONTRACT, OR ON TORT OR OTHER THEORY OF LIABILITY, AND REGARDLESS OF ANY ADVICE OR REPRESENTATIONS (WHETHER OR NOT IN WRITING) THAT MAY HAVE BEEN RENDERED BY SELLER CONCERNING THE DESIGN, MANUFACTURE, SALE, USE OR INSTALLATION OF THE PRODUCTS.
14. **INFRINGEMENT.** Seller at its expense will defend and hold Purchaser harmless from and against all damages, costs and expenses arising from any valid claim of infringement by a third party with respect to any patent or other intellectual property rights (collectively, the "Intellectual Property Rights") caused by Products originally manufactured by Seller, provided Purchaser
- (a) has not modified such Products,
  - (b) gives Seller immediate notice in writing of any claim or commencement or threat of suit, and (c) permits Seller to defend or settle the same, and gives all immediate information, assistance and authority to enable Seller to do so. In the event any such originally manufactured Products are held to infringe an Intellectual Property Right and if Purchaser's use thereof is enjoined, Seller will, at its expense and option: (1) obtain for Purchaser the right to continue using the Products, (2) supply non-infringing Products, (3) modify the Products so that they become non-infringing, or (4) refund the then market value of such Products. In no event shall Seller's liability exceed the sale price of the infringing Products. THE FOREGOING REPRESENTS SELLER'S ENTIRE AND EXCLUSIVE OBLIGATION WITH RESPECT TO ANY CHARGE OF INFRINGEMENT OF ANY INTELLECTUAL PROPERTY RIGHT AND IS IN LIEU OF ANY STATUTORY WARRANTY RELATING TO INFRINGEMENT. Notwithstanding the foregoing, Seller shall have no liability as to any Products or parts thereof that are manufactured or modified by Purchaser or a third party, or that are manufactured or modified by Seller in accordance with Purchaser's specifications. Purchaser will defend and hold Seller harmless from and against all damages, costs and expenses whatsoever arising from any claim for infringement of any Intellectual Property Rights relating to Products that have been manufactured or modified by Seller according to specifications provided by Purchaser.
15. **CERTAIN LAWS.** Seller will comply with the applicable requirements of the Fair Labor Standards Act of 1938, as amended, Executive Order 11246, and THE rules, regulations and orders of the Secretary of Labor relating thereto.
16. **PERIOD FOR ACCEPTING QUOTATIONS.** Unless accepted without modification within thirty (30) days of issuance, or prior to withdrawal by Seller if earlier, all quotations automatically expire at the end of such thirty (30) day period.
17. **PROVISIONS FOR INTERNATIONAL TRANSACTIONS.** The following provisions shall apply if the Products are to be shipped to Purchaser at a location outside the United States, and apply regardless of other provisions set forth in these Terms and Conditions:
- (a) The 1980 United Nations Convention on Contracts for the International Sale of Products shall not apply.
  - (b) Except as otherwise provided expressly stated in the agreement, terms of delivery are Ex-Works (within the meaning of INCOTERMS 2000) and all customs fees, import duties, cargo insurance, taxes and other charges imposed on or relating to the purchase or sale of the Products shall be paid by Purchaser in addition to the stated price.
  - (c) Except as otherwise provided expressly stated elsewhere in the agreement, payment shall be made by issuance to Seller of an irrevocable letter of credit which (i) is issued and confirmed by a U.S. bank acceptable to Seller, (ii) is governed by the Uniform Customs and Practice for Documentary Credits (UCP 600) and otherwise acceptable in form and substance to Seller, and (iii) provides for payment to Seller of the purchase price in U.S. dollars upon presentation by Seller of Seller's certification and/or such other documents as shall be required by the letter of credit. All banking and other charges for such letter of credit shall be for the account of Purchaser.
-

- (d) Prices include Seller's standard commercial export packaging which may vary depending on whether shipment is made by air, land or sea. Except as otherwise provided expressly stated in the agreement, Purchaser will bear any additional expenses required to satisfy Purchaser's packaging requirements. Packages will be marked in accordance with Purchaser's instructions, if any. Seller shall furnish packing lists and such other information as may be necessary to enable Purchaser's agent to prepare documents required for export shipment.
- (e) All shipments hereunder are subject to compliance with the U.S. Export Administration Act, as amended, regulations thereunder and all other U.S. laws and regulations concerning exports. Purchaser shall comply with all such laws and regulations concerning the use, disposition, re-export and sale of the Products provided hereunder.
18. **GENERAL.** No modification or waiver of the agreement or any of its provisions is valid unless expressly agreed to by Seller in writing, and no waiver by Seller of any default under the agreement is a waiver of any other or subsequent default. The unenforceability or invalidity of one or more of the provisions of the agreement will not affect the enforceability or validity of any other provision of the agreement. Purchaser may not assign any of its rights, duties or obligations under the agreement without Seller's prior written consent and any attempted assignment without such consent, even if by operation of law, will be void. The agreement is governed by and shall be construed in accordance with the laws of the State of Wisconsin, including the Uniform Commercial Code as enacted by such state, without giving effect to its conflict of laws principles.

## Return Policy

This policy is intended for returns that are not covered by product warranty, i.e. wrong pump or part was ordered, customer canceled order, etc. Before returning any product, contact us for a Returned Material Authorization Number (RMA#). This will eliminate confusion when the parts are received and facilitate processing the return. No action will be taken on returned parts without an RMA.

Type of Return	Restocking Charge
Standard pump with a replacement order	10%
Standard pump without a replacement order	20%
Standard parts with a replacement order	5%
Standard parts without a replacement order	10%

Additional restocking charges may be assessed for any of the following circumstances.

1. Special order motors and seals are not returnable unless we have a use for them. Credit will be determined on a case-by-case basis.
2. Impellers that are trimmed to a diameter that we don't regularly use are not returnable. Credit will be determined on a case-by-case basis.
3. Used seals and motors are not returnable.
4. For any pumps and/or parts purchased over (1) year ago, credit will be determined on a case-by-case basis.

## CREDITS

Credit will be issued only after parts are returned and inspected. Customer is responsible for packaging parts so they are returned in "as new" condition. Any labor required by Ampco to return the parts to "as new" condition will be deducted from the credit.

THIS PAGE INTENTIONALLY LEFT BLANK



THIS PAGE INTENTIONALLY LEFT BLANK

THIS PAGE INTENTIONALLY LEFT BLANK





Ampco Pumps Company  
2045 W. Mill Road Glendale, WI 53209  
Phone: (800) 737-8671 or (414) 643-1852  
Fax: (414) 643-4452  
Email: [ampcoocs@ampcopumps.com](mailto:ampcoocs@ampcopumps.com)

---

**For additional information on the ZP3 series and other Ampco Pumps products,  
please visit our website: [www.ampcopumps.com](http://www.ampcopumps.com)**